

PLOTTED/REVISED: 29-DEC-2021

PLOT NAME: SQUARE TUBE SIGN MOUNTING DETAIL
PATH & FILENAME: OTST\Signing\Typicals\Standard Plans\DETAIL Versions\SQUARE TUBE SIGN MOUNTING DETAILS.dgn

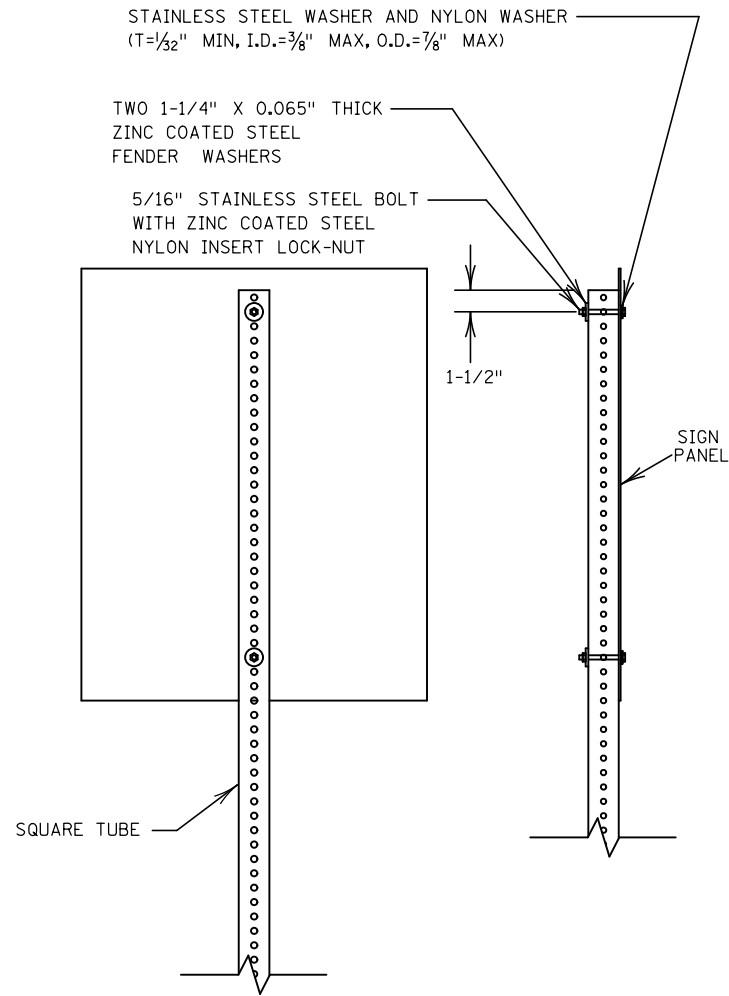

FOR SIGN PANELS UP TO 30" WIDE

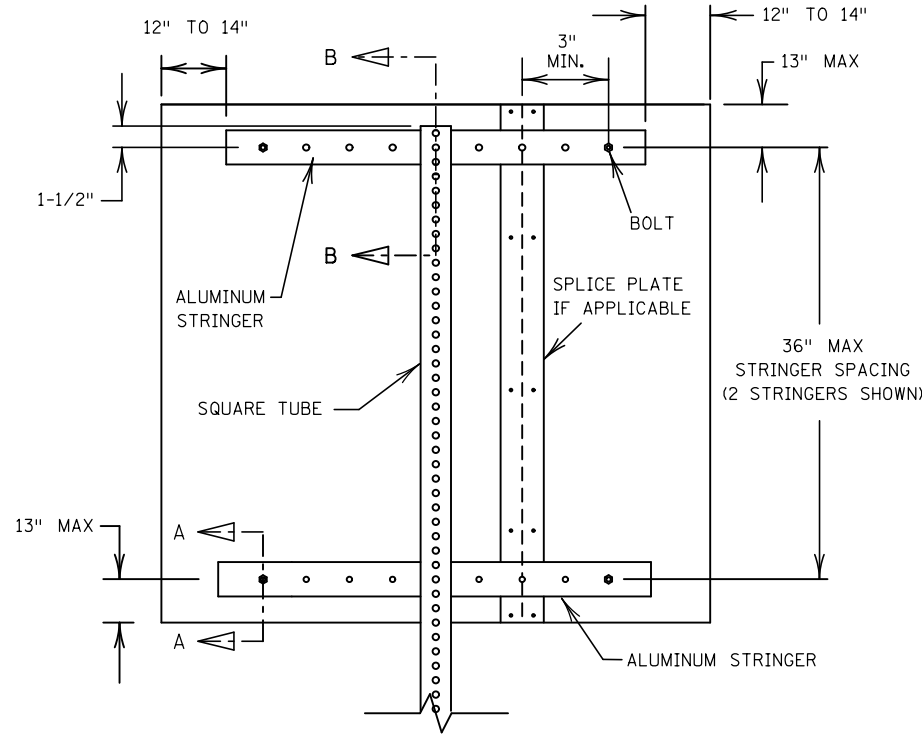

FOR SIGN PANELS 36" WIDE
OR GREATER ON ONE POST

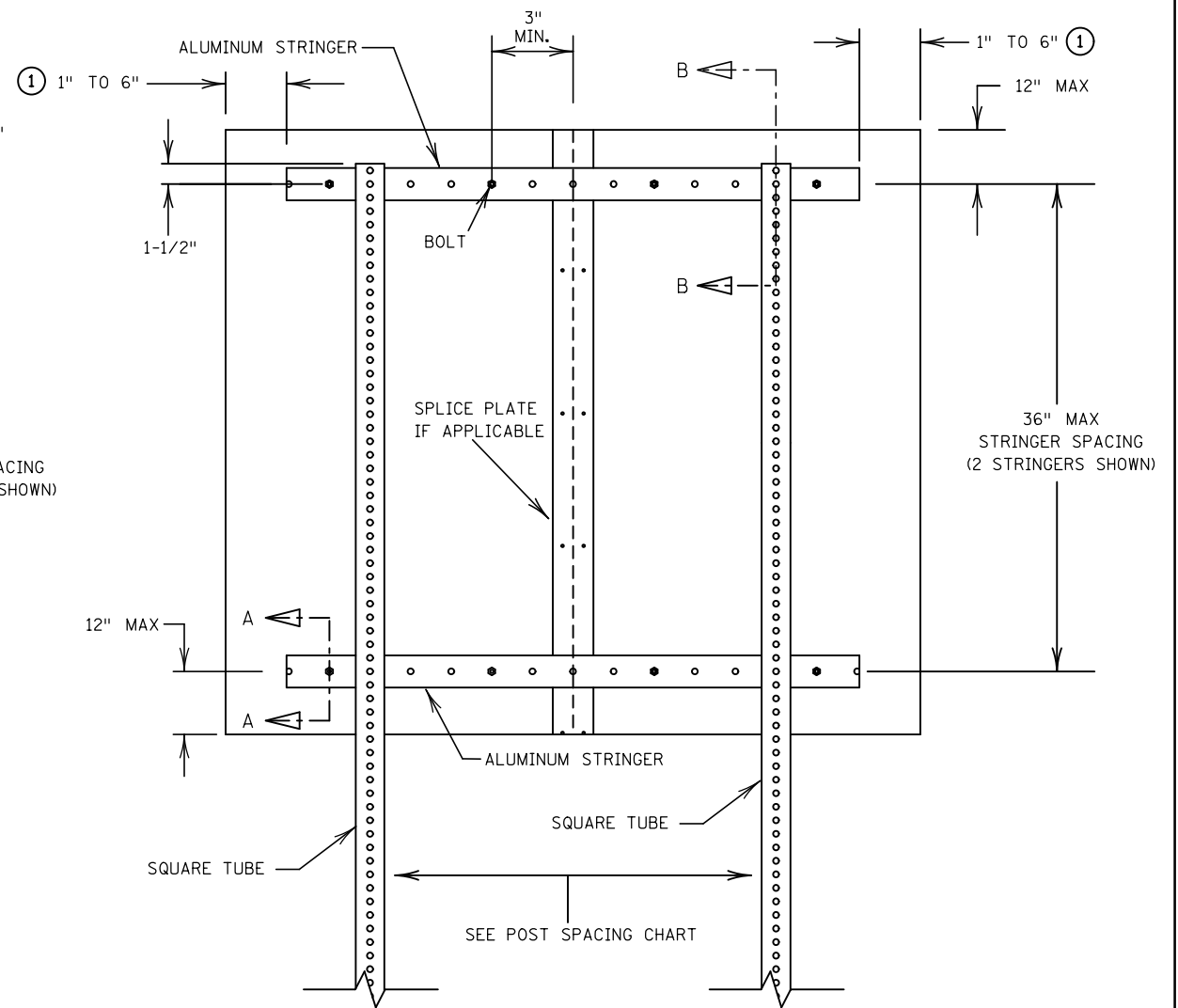

FOR SIGN PANELS ON TWO OR MORE POSTS

① IF POST SPACING REQUIRES PLACEMENT OF A POST WITHIN THIS AREA, EXTEND STRINGERS AS NEEDED TO ACCOMMODATE THE STRINGER TO POST CLAMP.

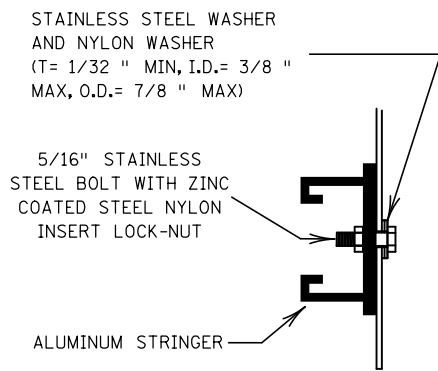

VIEW A-A

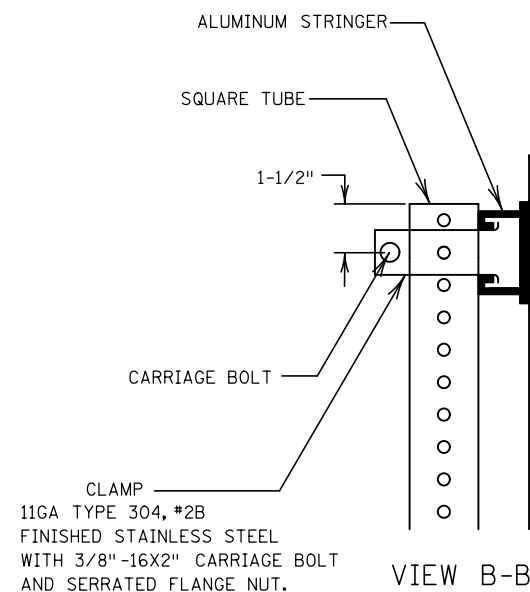

VIEW B-B

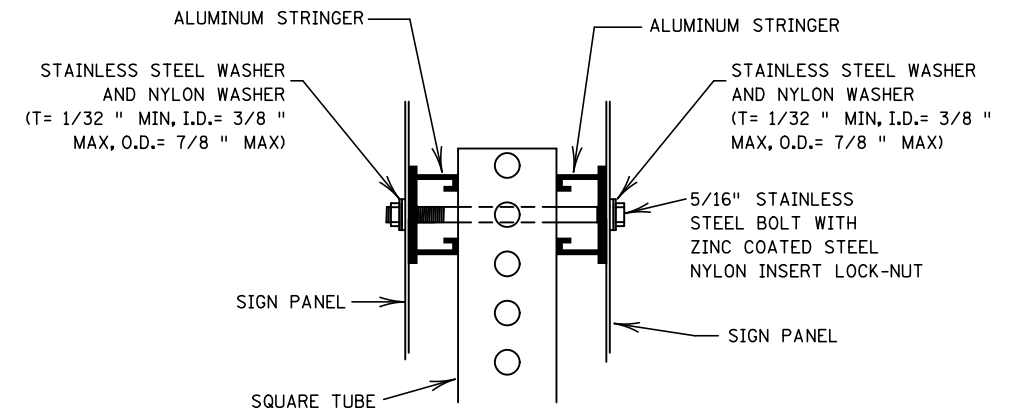
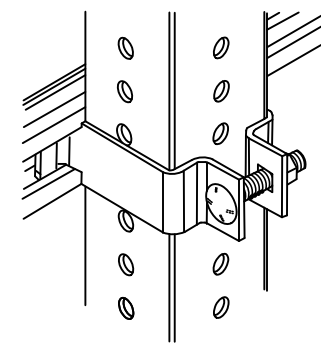
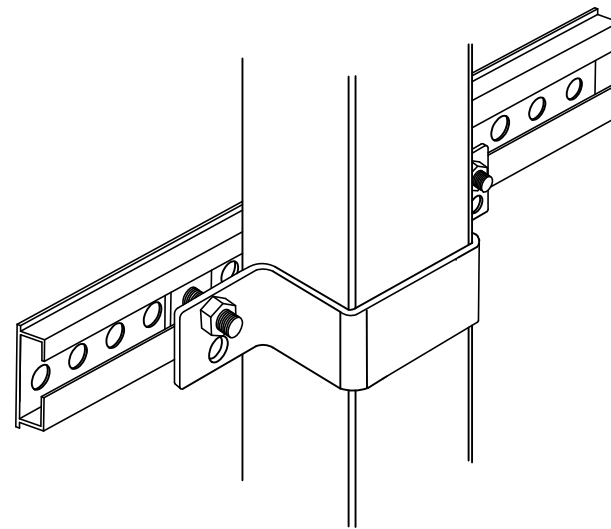

BACK TO BACK
SIGN MOUNTING WITH STRINGERS

NOTES:

1. BOLT SIGN PANELS TO STRINGERS OR RISER POSTS AT NO GREATER THAN 24 INCH SPACING OR ACCORDING TO THE MNDOT STANDARD SIGNS AND MARKINGS MANUAL FOR MOUNTING HOLES (PUNCH CODES) INFORMATION.
2. STRINGERS SHALL BE CENTERED ON SIGN PANEL.

REV 7/01/21

SQUARE TUBE
SIGN MOUNTING DETAILS

1 OF 3

PLOTTED/REVISED: 29-DEC-2021

PLOT NAME: SQUARE TUBE SIGN MOUNTING DETAIL
 PATH & FILENAME: OTST\Signing\Typicals\Standard Plans\DETAIL Versions\SQUARE TUBE SIGN MOUNTING DETAIL.S.dgn

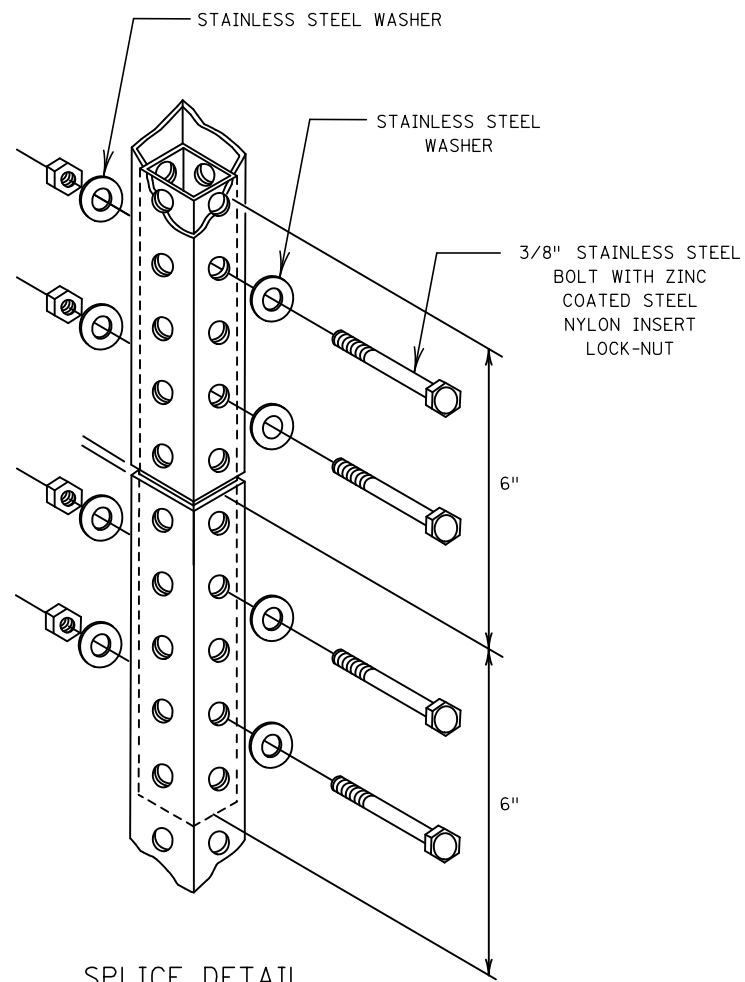

SPLICE DETAIL

NO MORE THAN ONE SPLICE PER POST.

WHEN USED MUST BE PLACED AT LEAST 8 FEET ABOVE GROUND. THE PREFERRED PLACEMENT LOCATION IS BEHIND THE SIGN PANEL.

INTERIOR POST STUD SHALL BE ONE SIZE SMALLER FOR A TIGHT FIT. IF RISER POST IS 2-1/2", INTERIOR POST IS 2-3/16". IF RISER POST IS 2", INTERIOR POST IS 1-3/4".

PANEL WIDTH	SQUARE TUBE POST SPACING							
	2 POSTS	3 POSTS	4 POSTS	5 POSTS	6 POSTS	7 POSTS	8 POSTS	
(IN)	(IN)	(IN)	(IN)	(IN)	(IN)	(IN)	(IN)	
42	15							
48	21							
54	30							
60	36							
66	36							
72	42							
78	42							
84	48							
90	48	42						
96	48	42						
102	54	42						
108	54	42						
114	60	42						
120	60	48						
126	66	48						
132	66	48	42					
138	72	48	42					
144	72	48	42					
150	78	54	42					
156	78	54	42					
162	84	54	42					
168	84	60	48					
174	90	60	48	42				
180	90	60	48	42				
186	96	66	48	42				
192	96	66	48	42				
198	102	66	54	42				
204	102	72	54	42				
210	108	72	54	42				
216	108	72	54	48	42			
222	114	78	60	48	42			
228	114	78	60	48	42			
234	120	78	60	48	42			
240	120	84	60	48	42			
246		84	66	54	42			
252		84	66	54	42			
258		90	66	54	42	42		
264		90	66	54	48	42		
270		90	72	54	48	42		
276		96	72	60	48	42		
282		96	72	60	48	42		
288		96	72	60	48	42		
294		102	78	60	54	42		
300		102	78	60	54	42	42	
306		102	78	66	54	42	42	
312		108	78	66	54	48	42	
318		108	84	66	54	48	42	
324		108	84	66	54	48	42	
330		114	84	66	60	48	42	
336		114	84	72	60	48	42	

DISTANCES ARE CENTER-TO-CENTER OF POSTS

REV 7/01/21

SQUARE TUBE SIGN MOUNTING DETAILS

2 OF 3

