

# Minnesota Standard Signs and Markings Manual 2020

## Standard Sign Details: Splice Plate Details

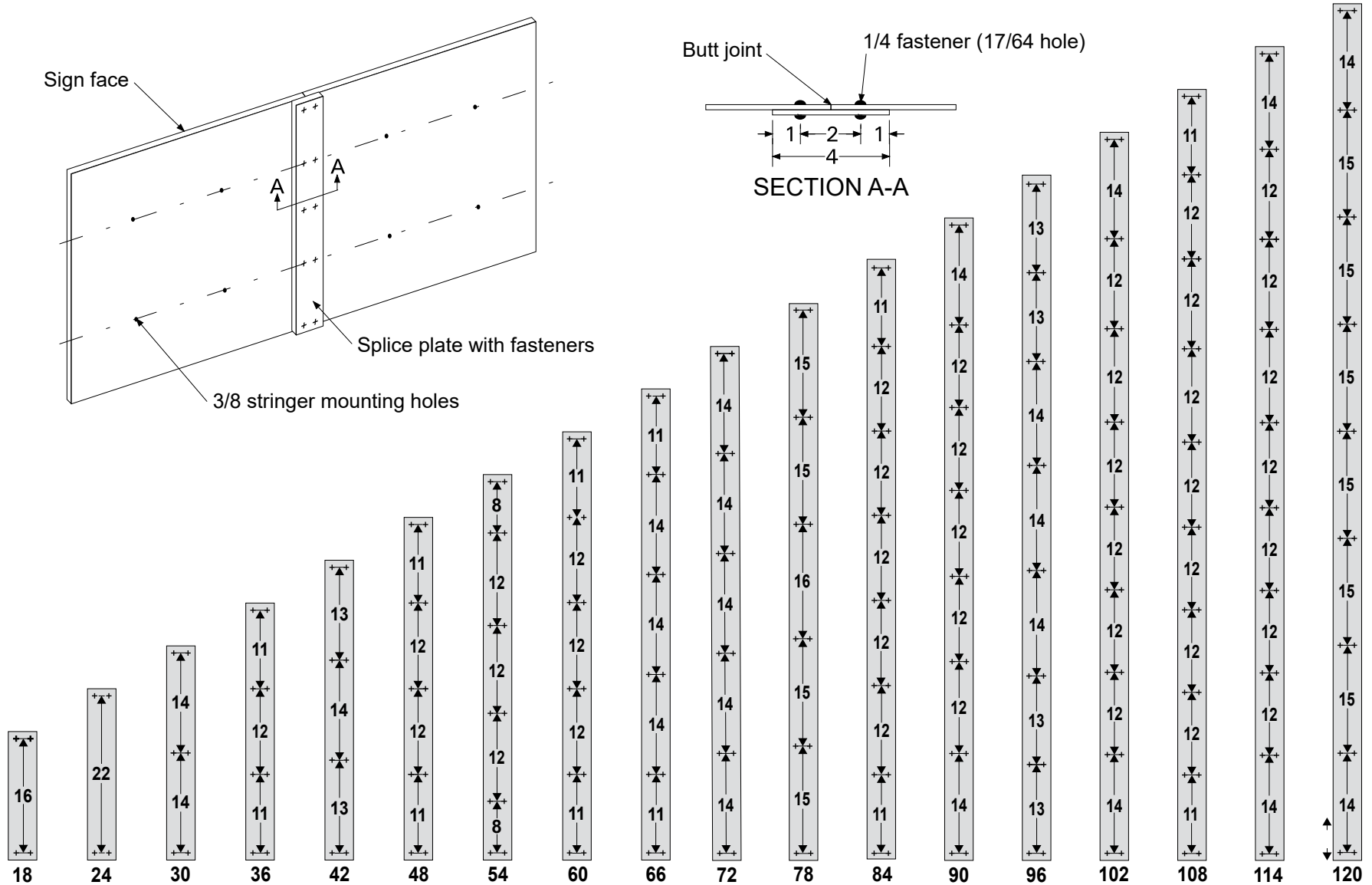
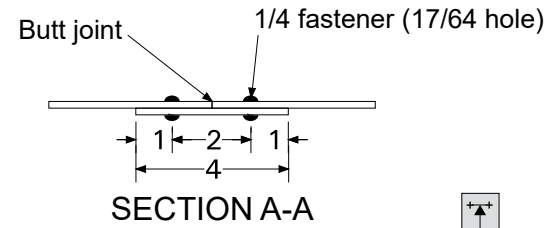
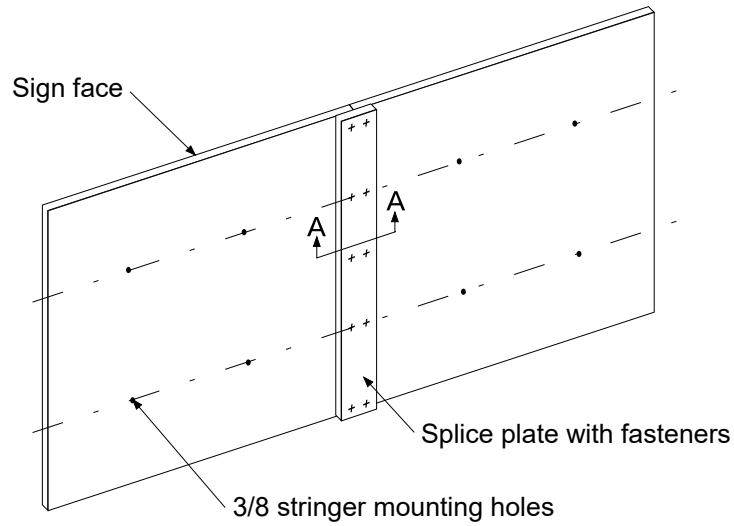

**NOTES:**

1. All dimensions are in inches.
2. Splice plates shall be made of the same material as the sign panel with a minimum thickness equal to that of the panel.
3. The end fasteners are located 1" in from the end of the splice plate.
4. All sign panel splices shall be vertical.

# Minnesota Standard Signs and Markings Manual 2020

## Standard Sign Details: Stringer Placement

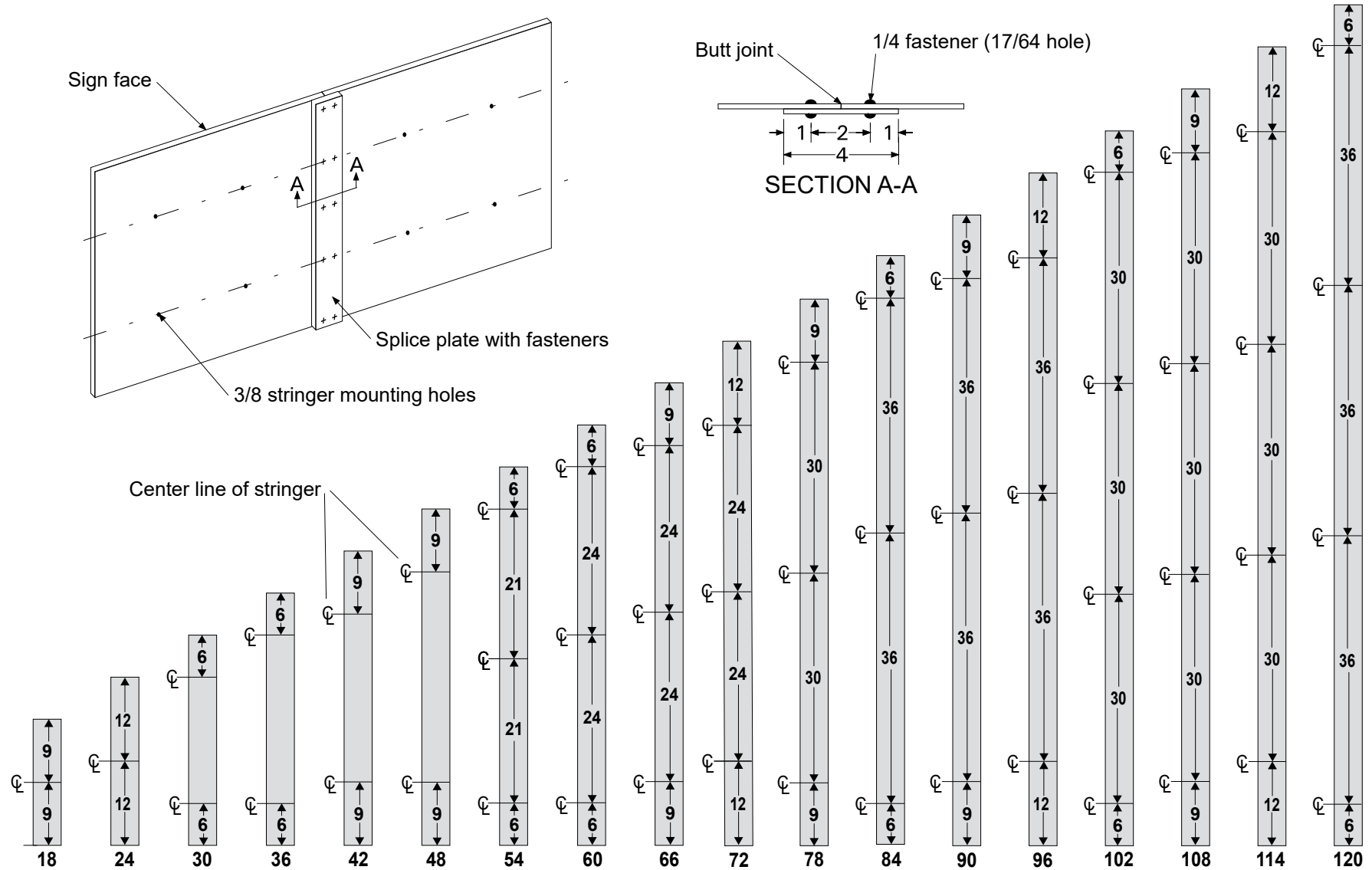

**NOTES:**

1. All dimensions are in inches.
2. 3/8" stringer mounting holes shall be spaced vertically as detailed for each sign height above. Horizontally the holes shall be spaced on 24" centers maximum, beginning 10" in from the edge of the sign panel.