

TMS / ITS - Approved Products List

TMS / ITS Fiber Optic Pulling Vault

The Fiber Optic Pulling Vault shall be constructed in accordance with the following:

- A.** The Fiber Optic Pulling Vault shall be a pre-cast polymer concrete structure reinforced with fiberglass.
- B.** The Fiber Optic Pulling Vault body and cover shall have a minimum design load of 15,000 pounds and minimum test load of 20,000 pounds.
- C.** All hardware shall be stainless steel.
- D.** The Fiber Optic Pulling Vault body shall have an open bottom.
- E.** The cover shall contain:
 - 1.** A non-slip surface.
 - 2.** Two lifting eyes.
 - 3.** Two 3/8"-16 UNC x 3-1/2" long hex head bolts with self aligning replaceable nuts positioned in holes that allow drainage of soil and debris.
 - 4.** Identification Logo: Mn/DOT Fiber.

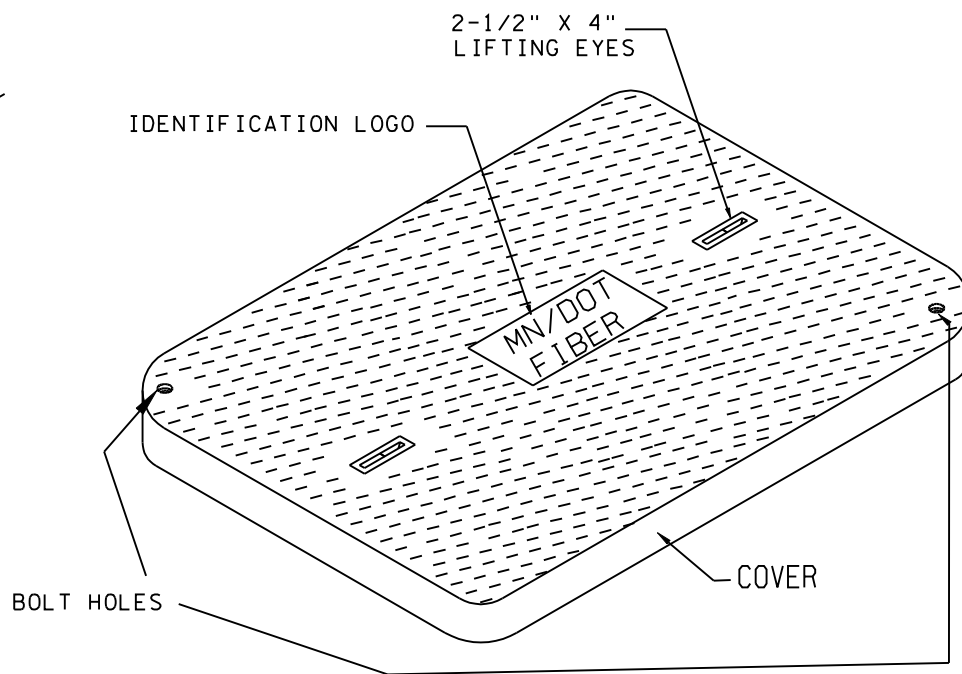
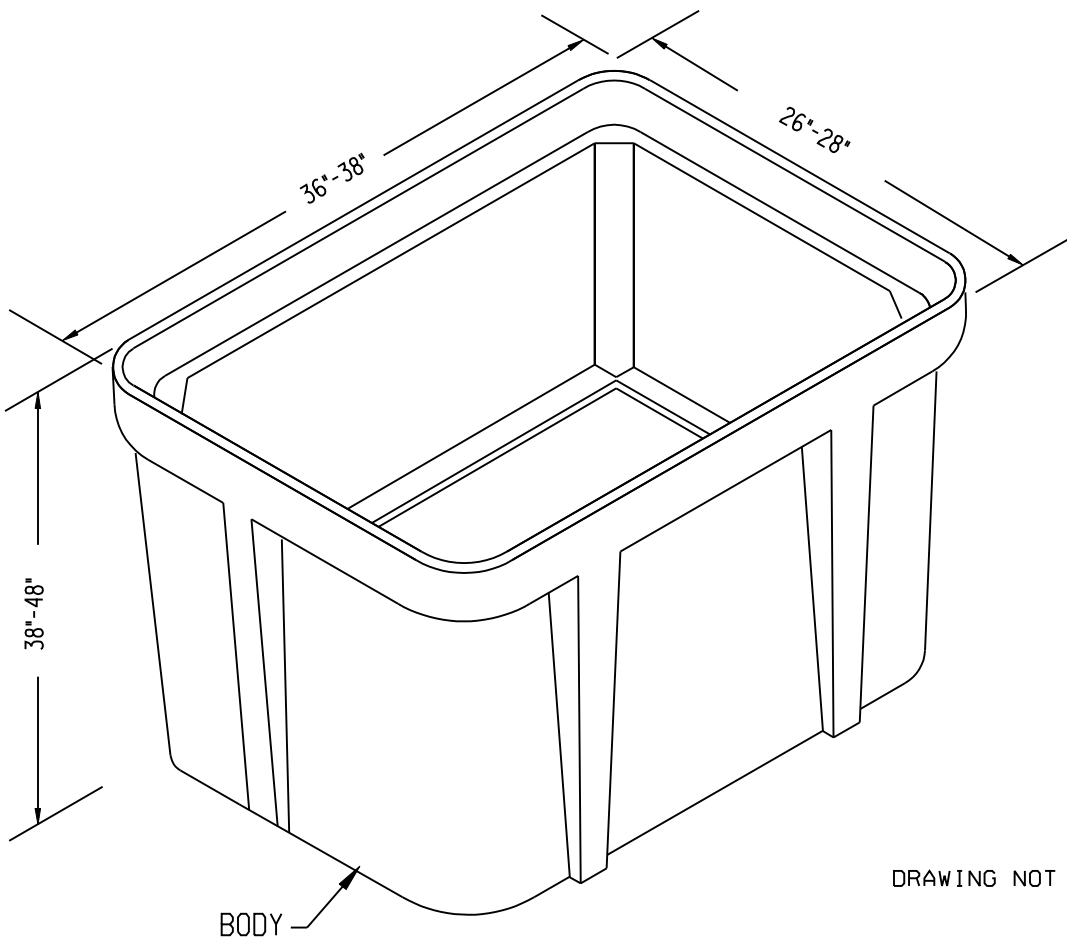

DRAWING NOT TO SCALE

FIBER OPTIC PULLING VAULT