

## TMS / ITS - Approved Products List

### TMS / ITS Fiber Optic Pulling Vault

The Fiber Optic Pulling Vault shall be constructed in accordance with the following:

- A. Shall be a pre-cast polymer concrete structure reinforced with fiberglass.
- B. Shall have a minimum design load of 15,000 pounds and minimum test load of 20,000 pounds.
- C. All hardware shall be stainless steel.
- D. Vault body shall have an open bottom.
- E. The cover shall have:
  - a. A non-slip surface.
  - b. Two lifting eyes.
  - c. Two 3/8"-16 UNC x 3-1/2" long hex head bolts with self aligning replaceable nuts positioned in holes that allow drainage of soil and debris.
  - d. Identification Logo embossed to reflect the specific application:
    - 1. "MnDOT TMS" for ITS projects.
    - 2. "MnDOT Signals" for traffic control signal projects.
    - 3. "MnDOT Lighting" for roadway lighting projects.
    - 4. "MnDOT Anti-Icing" for anti-icing projects
- F. An extension ring shall be available that increases the overall height by 3 to 6 inches.

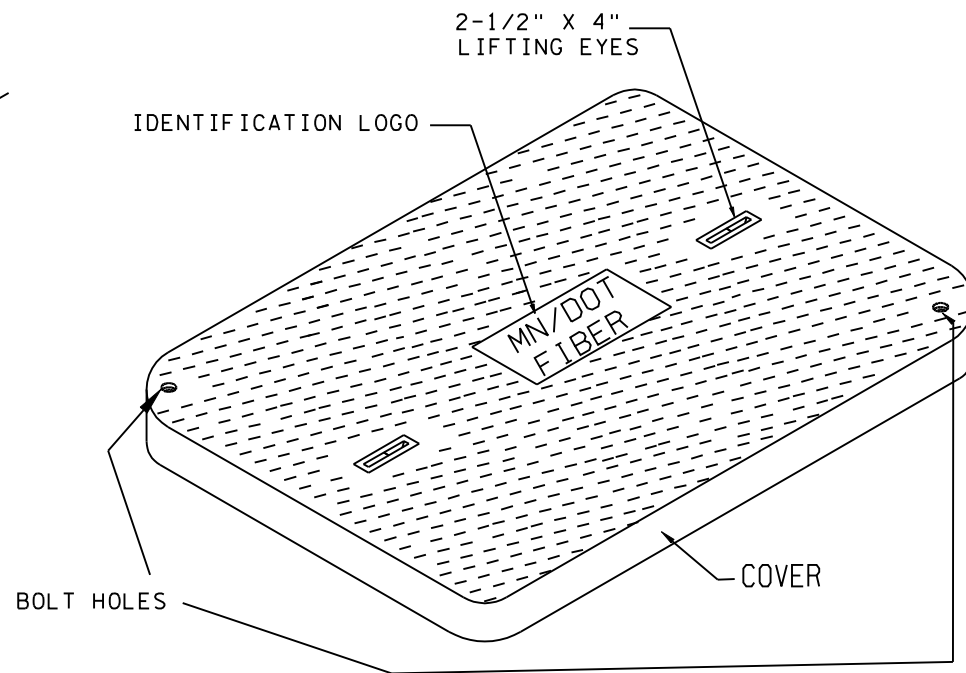
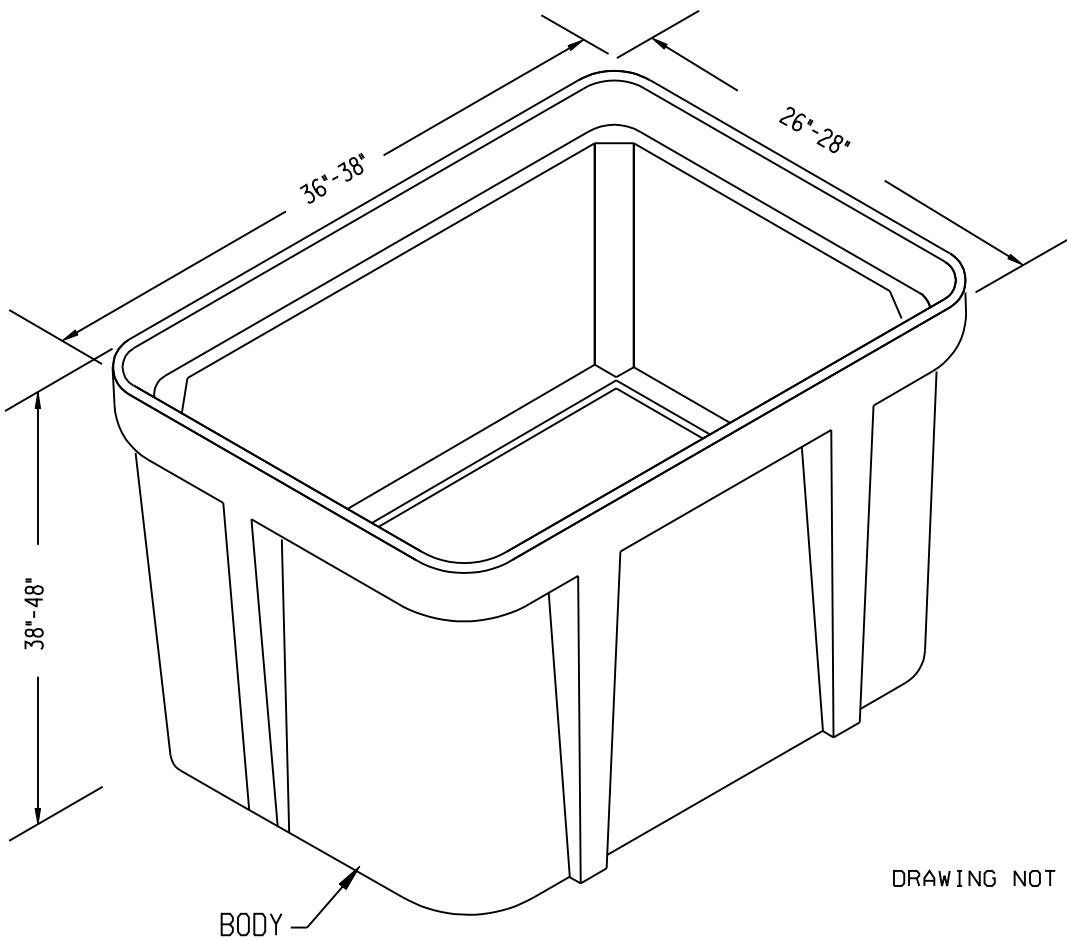

DRAWING NOT TO SCALE

FIBER OPTIC PULLING VAULT