



MINNESOTA DEPT. OF TRANSPORTATION

TRAFFIC DATA COLLECTION - METRO

TH-952 / ROBERT ST. AT EMERSON AVE.
 REF.PT.: 128.425
 JAMAR# 631 SK
 TURN MOVEMENT COUNT

File Name : TH-952 AT EMERSON 2006
 Site Code : 00000000
 Start Date : 6/28/2006
 Page No : 1

Groups Printed- CARS & TRUCKS

Start Time	TH-952 / ROBERT ST. Southbound				EMERSON AVE. Westbound				TH-952 / ROBERT ST. Northbound				EMERSON AVE. Eastbound				Int. Total
	Left	Thru	Right	Peds	Left	Thru	Right	Peds	Left	Thru	Right	Peds	Left	Thru	Right	Peds	
06:00	1	55	1	0	4	2	0	0	2	50	0	0	4	1	1	0	121
06:15	4	70	4	0	3	0	5	0	2	53	1	0	4	1	5	0	152
06:30	2	80	1	0	2	2	4	0	2	93	0	0	7	2	5	0	200
06:45	1	74	4	0	4	0	4	0	0	96	4	0	6	1	4	0	198
Total	8	279	10	0	13	4	13	0	6	292	5	0	21	5	15	0	671
07:00	1	74	4	0	1	3	2	0	2	107	3	0	4	2	5	0	208
07:15	2	89	4	0	3	2	4	0	4	136	6	0	9	5	9	0	273
07:30	3	95	4	0	9	5	5	0	3	134	6	0	10	4	6	0	284
07:45	6	132	7	0	5	3	6	0	3	155	3	0	7	8	3	0	338
Total	12	390	19	0	18	13	17	0	12	532	18	0	30	19	23	0	1103
08:00	4	119	6	0	8	5	4	0	1	128	8	0	8	9	12	0	312
08:15	3	107	12	0	4	6	9	0	6	126	4	0	9	5	13	0	304
08:30	3	137	5	0	7	9	4	0	5	124	13	0	11	5	12	0	335
08:45	3	150	6	0	17	7	7	0	7	150	28	0	9	18	13	0	415
Total	13	513	29	0	36	27	24	0	19	528	53	0	37	37	50	0	1366
15:00	6	210	7	0	13	12	8	0	8	188	10	0	13	7	6	0	488
15:15	4	245	7	0	12	10	4	0	14	209	13	0	12	11	14	0	555
15:30	9	215	8	0	13	9	6	0	6	212	12	0	21	8	7	0	526
15:45	3	232	10	0	6	12	4	0	10	243	18	0	6	9	7	0	560
Total	22	902	32	0	44	43	22	0	38	852	53	0	52	35	34	0	2129
16:00	8	241	13	0	15	7	9	0	12	218	11	0	8	9	5	0	556
16:15	5	251	6	0	11	2	9	0	13	251	6	0	19	8	8	0	589
16:30	10	257	11	0	12	17	5	0	8	233	14	0	12	13	3	0	595
16:45	7	282	12	0	14	16	9	0	8	251	25	0	12	14	21	0	671
Total	30	1031	42	0	52	42	32	0	41	953	56	0	51	44	37	0	2411
17:00	4	291	9	0	22	24	8	0	16	257	7	0	17	6	19	0	680
17:15	7	280	15	0	9	9	8	0	16	262	9	0	5	7	11	0	638
17:30	7	242	13	0	9	10	10	0	18	238	12	0	11	12	10	0	592
17:45	6	247	7	0	9	16	8	0	13	226	8	0	11	9	21	0	581
Total	24	1060	44	0	49	59	34	0	63	983	36	0	44	34	61	0	2491
Grand Total	109	4175	176	0	212	188	142	0	179	4140	221	0	235	174	220	0	10171
Apprch %	2.4	93.6	3.9	0	39.1	34.7	26.2	0	3.9	91.2	4.9	0	37.4	27.7	35	0	
Total %	1.1	41	1.7	0	2.1	1.8	1.4	0	1.8	40.7	2.2	0	2.3	1.7	2.2	0	



MINNESOTA DEPT. OF TRANSPORTATION

TRAFFIC DATA COLLECTION - METRO

TH-952 / ROBERT ST. AT EMERSON AVE.
 REF.PT.: 128.425
 JAMAR# 631 SK
 TURN MOVEMENT COUNT

File Name : TH-952 AT EMERSON 2006
 Site Code : 00000000
 Start Date : 6/28/2006
 Page No : 2

Start Time	TH-952 / ROBERT ST. Southbound					EMERSON AVE. Westbound					TH-952 / ROBERT ST. Northbound					EMERSON AVE. Eastbound					Int. Total
	Left	Thru	Right	Peds	App. Total	Left	Thru	Right	Peds	App. Total	Left	Thru	Right	Peds	App. Total	Left	Thru	Right	Peds	App. Total	
Peak Hour Analysis From 06:00 to 08:45 - Peak 1 of 1																					
Peak Hour for Entire Intersection Begins at 08:00																					
08:00	4	119	6	0	129	8	5	4	0	17	1	128	8	0	137	8	9	12	0	29	312
08:15	3	107	12	0	122	4	6	9	0	19	6	126	4	0	136	9	5	13	0	27	304
08:30	3	137	5	0	145	7	9	4	0	20	5	124	13	0	142	11	5	12	0	28	335
08:45	3	150	6	0	159	17	7	7	0	31	7	150	28	0	185	9	18	13	0	40	415
Total Volume	13	513	29	0	555	36	27	24	0	87	19	528	53	0	600	37	37	50	0	124	1366
% App. Total	2.3	92.4	5.2	0		41.4	31	27.6	0		3.2	88	8.8	0		29.8	29.8	40.3	0		
PHF	.813	.855	.604	.000	.873	.529	.750	.667	.000	.702	.679	.880	.473	.000	.811	.841	.514	.962	.000	.775	.823

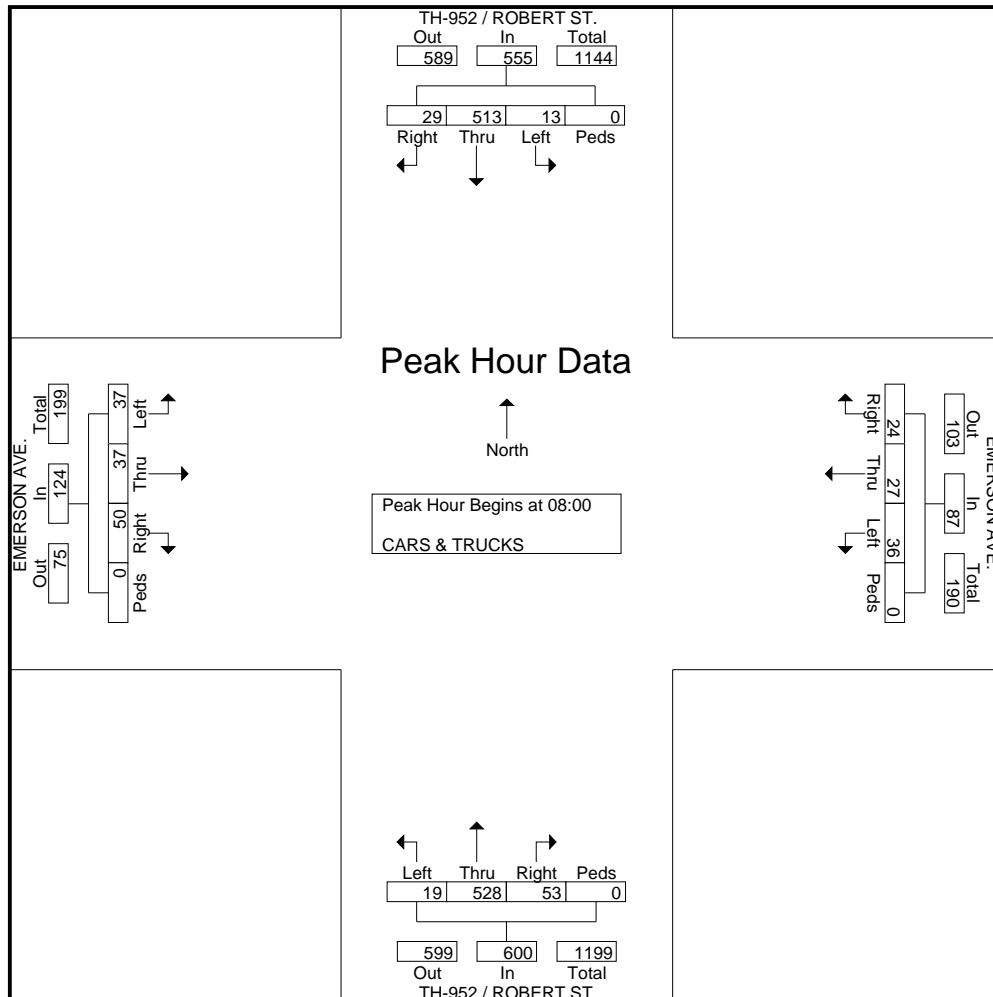



MINNESOTA DEPT. OF TRANSPORTATION

TRAFFIC DATA COLLECTION - METRO

TH-952 / ROBERT ST. AT EMERSON AVE.
 REF.PT.: 128.425
 JAMAR# 631 SK
 TURN MOVEMENT COUNT

File Name : TH-952 AT EMERSON 2006
 Site Code : 00000000
 Start Date : 6/28/2006
 Page No : 3

Start Time	TH-952 / ROBERT ST. Southbound					EMERSON AVE. Westbound					TH-952 / ROBERT ST. Northbound					EMERSON AVE. Eastbound					Int. Total
	Left	Thru	Right	Peds	App. Total	Left	Thru	Right	Peds	App. Total	Left	Thru	Right	Peds	App. Total	Left	Thru	Right	Peds	App. Total	
Peak Hour Analysis From 15:00 to 17:45 - Peak 1 of 1																					
Peak Hour for Entire Intersection Begins at 16:30																					
16:30	10	257	11	0	278	12	17	5	0	34	8	233	14	0	255	12	13	3	0	28	595
16:45	7	282	12	0	301	14	16	9	0	39	8	251	25	0	284	12	14	21	0	47	671
17:00	4	291	9	0	304	22	24	8	0	54	16	257	7	0	280	17	6	19	0	42	680
17:15	7	280	15	0	302	9	9	8	0	26	16	262	9	0	287	5	7	11	0	23	638
Total Volume	28	1110	47	0	1185	57	66	30	0	153	48	1003	55	0	1106	46	40	54	0	140	2584
% App. Total	2.4	93.7	4	0		37.3	43.1	19.6	0		4.3	90.7	5	0		32.9	28.6	38.6	0		
PHF	.700	.954	.783	.000	.975	.648	.688	.833	.000	.708	.750	.957	.550	.000	.963	.676	.714	.643	.000	.745	.950

