



MINNESOTA DEPT OF TRANSPORTATION

TRAFFIC DATA COLLECTION - METRO

TH-95 AT CO. RD.-81 / REED AVE
 Ref.Pt.: 067.371
 JAMAR# 632 DR
 TURN MOVEMENT COUNT

File Name : TH-95 AT Co Rd 81 REED AVE 2010
 Site Code : 00000000
 Start Date : 9/22/2010
 Page No : 1

Groups Printed- Unshifted

Start Time	CO RD 81 REED AVE Southbound				TH 95 Westbound				CO RD 81 REED AVE Northbound				TH 95 Eastbound				Int. Total
	Left	Thru	Right	Peds	Left	Thru	Right	Peds	Left	Thru	Right	Peds	Left	Thru	Right	Peds	
06:00	1	0	0	0	0	13	0	0	0	0	0	0	0	3	0	0	17
06:15	0	0	0	0	0	18	0	0	0	0	0	0	0	12	0	0	30
06:30	2	0	0	0	0	15	0	0	1	1	0	0	0	13	0	0	32
06:45	1	0	0	0	0	21	0	0	0	0	0	0	0	15	0	0	37
Total	4	0	0	0	0	67	0	0	1	1	0	0	0	43	0	0	116
07:00	0	0	0	0	1	18	0	0	0	0	0	0	0	5	0	0	24
07:15	1	0	0	0	0	15	0	0	0	0	0	0	0	7	1	0	24
07:30	0	0	1	0	0	22	0	0	0	0	0	0	0	17	0	0	40
07:45	0	0	0	0	0	16	0	0	0	0	0	0	1	25	0	0	42
Total	1	0	1	0	1	71	0	0	0	0	0	0	1	54	1	0	130
08:00	1	0	1	0	0	16	0	0	1	0	0	0	0	28	0	0	47
08:15	1	1	0	0	0	12	0	0	0	0	0	0	0	18	1	0	33
08:30	1	0	2	0	0	19	1	0	0	0	0	0	0	25	0	0	48
08:45	1	0	1	0	0	26	1	0	0	0	0	0	0	16	0	0	45
Total	4	1	4	0	0	73	2	0	1	0	0	0	0	87	1	0	173
*** BREAK ***																	
15:00	2	0	1	0	0	22	1	0	0	0	0	0	0	21	0	0	47
15:15	1	0	0	0	0	23	1	0	2	0	0	0	0	33	1	0	61
15:30	0	0	3	0	0	22	0	0	0	1	0	0	0	22	0	0	48
15:45	0	0	1	0	0	28	1	0	0	0	0	0	0	36	0	0	66
Total	3	0	5	0	0	95	3	0	2	1	0	0	0	112	1	0	222
16:00	0	0	0	0	0	21	1	0	1	0	0	0	1	24	0	0	48
16:15	0	0	0	0	0	31	0	0	0	0	0	0	1	18	0	0	50
16:30	0	0	0	0	0	15	0	0	0	0	0	0	0	21	1	0	37
16:45	0	0	0	0	0	18	0	0	0	0	0	0	0	30	1	0	49
Total	0	0	0	0	0	85	1	0	1	0	0	0	2	93	2	0	184
17:00	0	0	0	0	0	23	2	0	0	0	0	0	0	25	0	0	50
17:15	1	0	1	0	0	24	1	0	1	0	0	0	0	23	2	0	53
17:30	1	1	0	0	0	16	0	0	0	1	0	0	1	23	2	0	45
17:45	0	1	1	0	0	23	0	0	1	0	0	0	1	14	0	0	41
Total	2	2	2	0	0	86	3	0	2	1	0	0	2	85	4	0	189
Grand Total	14	3	12	0	1	477	9	0	7	3	0	0	5	474	9	0	1014
Apprch %	48.3	10.3	41.4	0	0.2	97.9	1.8	0	70	30	0	0	1	97.1	1.8	0	
Total %	1.4	0.3	1.2	0	0.1	47	0.9	0	0.7	0.3	0	0	0.5	46.7	0.9	0	



MINNESOTA DEPT OF TRANSPORTATION

TRAFFIC DATA COLLECTION - METRO

TH-95 AT CO. RD.-81 / REED AVE
 Ref.Pt.: 067.371
 JAMAR# 632 DR
 TURN MOVEMENT COUNT

File Name : TH-95 AT Co Rd 81 REED AVE 2010
 Site Code : 00000000
 Start Date : 9/22/2010
 Page No : 2

Start Time	CO RD 81 REED AVE Southbound					TH 95 Westbound					CO RD 81 REED AVE Northbound					TH 95 Eastbound					Int. Total
	Left	Thru	Right	Peds	App. Total	Left	Thru	Right	Peds	App. Total	Left	Thru	Right	Peds	App. Total	Left	Thru	Right	Peds	App. Total	
Peak Hour Analysis From 06:00 to 08:45 - Peak 1 of 1																					
Peak Hour for Entire Intersection Begins at 08:00																					
08:00	1	0	1	0	2	0	16	0	0	16	1	0	0	0	1	0	28	0	0	28	47
08:15	1	1	0	0	2	0	12	0	0	12	0	0	0	0	0	0	18	1	0	19	33
08:30	1	0	2	0	3	0	19	1	0	20	0	0	0	0	0	0	25	0	0	25	48
08:45	1	0	1	0	2	0	26	1	0	27	0	0	0	0	0	0	16	0	0	16	45
Total Volume	4	1	4	0	9	0	73	2	0	75	1	0	0	0	1	0	87	1	0	88	173
% App. Total	44.4	11.1	44.4	0		0	97.3	2.7	0		100	0	0	0		0	98.9	1.1	0		
PHF	1.000																				

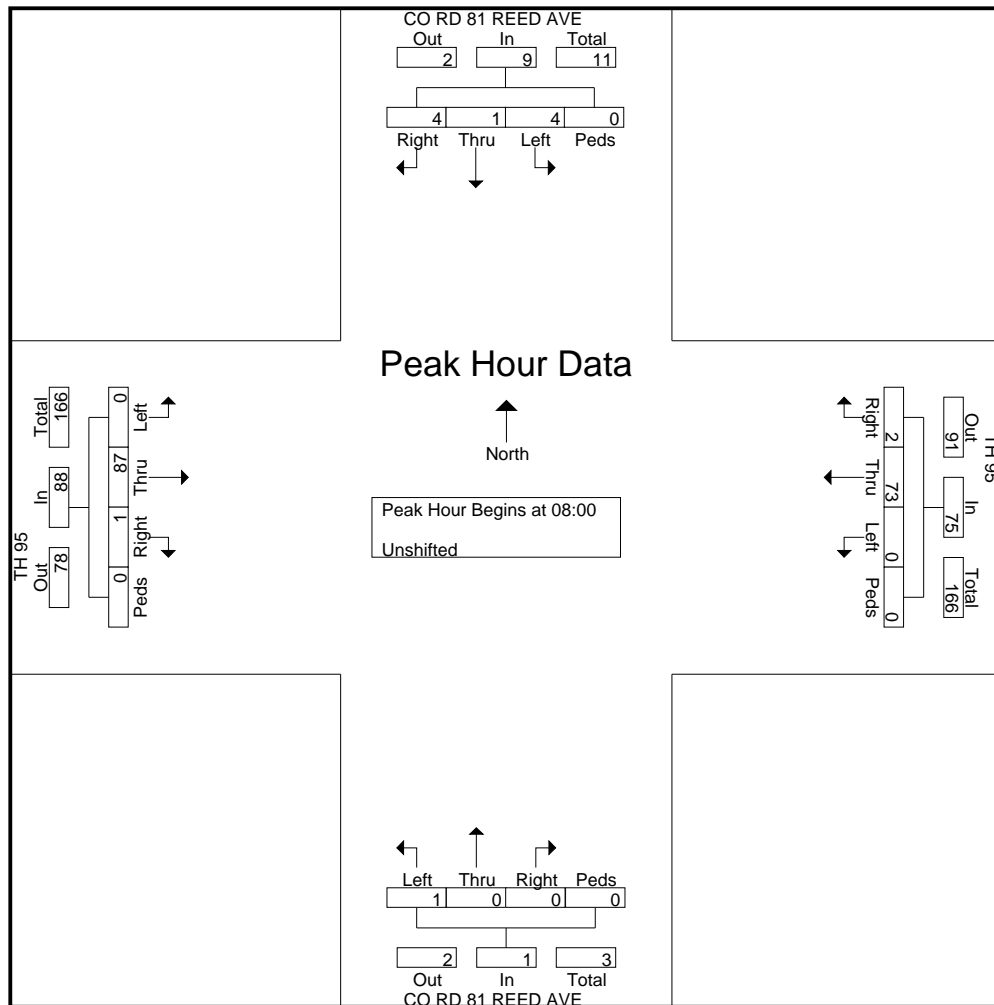



MINNESOTA DEPT OF TRANSPORTATION

TRAFFIC DATA COLLECTION - METRO

TH-95 AT CO. RD.-81 / REED AVE
 Ref.Pt.: 067.371
 JAMAR# 632 DR
 TURN MOVEMENT COUNT

File Name : TH-95 AT Co Rd 81 REED AVE 2010
 Site Code : 00000000
 Start Date : 9/22/2010
 Page No : 3

Start Time	CO RD 81 REED AVE Southbound					TH 95 Westbound					CO RD 81 REED AVE Northbound					TH 95 Eastbound					Int. Total
	Left	Thru	Right	Peds	App. Total	Left	Thru	Right	Peds	App. Total	Left	Thru	Right	Peds	App. Total	Left	Thru	Right	Peds	App. Total	
Peak Hour Analysis From 15:00 to 17:45 - Peak 1 of 1																					
Peak Hour for Entire Intersection Begins at 15:15																					
15:15	1	0	0	0	1	0	23	1	0	24	2	0	0	0	2	0	33	1	0	34	61
15:30	0	0	3	0	3	0	22	0	0	22	0	1	0	0	1	0	22	0	0	22	48
15:45	0	0	1	0	1	0	28	1	0	29	0	0	0	0	0	0	36	0	0	36	66
16:00	0	0	0	0	0	0	21	1	0	22	1	0	0	0	1	1	24	0	0	25	48
Total Volume	1	0	4	0	5	0	94	3	0	97	3	1	0	0	4	1	115	1	0	117	223
% App. Total	20	0	80	0		0	96.9	3.1	0		75	25	0	0		0.9	98.3	0.9	0		
PHF	.250	.000	.333	.000	.417	.000	.839	.750	.000	.836	.375	.250	.000	.000	.500	.250	.799	.250	.000	.813	.845

