



**MINNESOTA DEPT OF TRANSPORTATION**  
**TRAFFIC DATA COLLECTION - METRO**

TH-8 AT PLEASANT VALLEY RD/CSAH-26&82 File Name : TH-8 AT PLEASANT VALLEY RD 2006  
 REF.PT.: 014.327 Site Code : 00000000  
 JAMAR # 631 RE Start Date : 8/30/2006  
 TURN MOVEMENT COUNT Page No : 1

**Groups Printed- Cars & Trucks**

| Start Time    | PLEASANT VALLEY RD /CSAH-82 Southbound |      |       |      | TH-8 Westbound |      |       |      | PLEASANT VALLEY RD /CSAH-26 Northbound |      |       |      | TH-8 Eastbound |      |       |      | Int. Total |
|---------------|--|------|-------|------|----------------|------|-------|------|--|------|-------|------|----------------|------|-------|------|------------|
|               | Left                                   | Thru | Right | Peds | Left           | Thru | Right | Peds | Left                                   | Thru | Right | Peds | Left           | Thru | Right | Peds |            |
| 06:00         | 0                                      | 6    | 0     | 0    | 3              | 73   | 0     | 0    | 6                                      | 2    | 0     | 0    | 0              | 18   | 14    | 0    | 122        |
| 06:15         | 0                                      | 4    | 0     | 0    | 5              | 109  | 1     | 0    | 8                                      | 0    | 1     | 0    | 0              | 29   | 23    | 0    | 180        |
| 06:30         | 0                                      | 10   | 0     | 0    | 6              | 101  | 0     | 0    | 8                                      | 0    | 2     | 0    | 0              | 31   | 25    | 0    | 183        |
| 06:45         | 0                                      | 6    | 0     | 0    | 11             | 105  | 1     | 0    | 11                                     | 0    | 0     | 0    | 0              | 25   | 24    | 0    | 183        |
| Total         | 0                                      | 26   | 0     | 0    | 25             | 388  | 2     | 0    | 33                                     | 2    | 3     | 0    | 0              | 103  | 86    | 0    | 668        |
| 07:00         | 1                                      | 3    | 0     | 0    | 2              | 85   | 0     | 0    | 10                                     | 1    | 0     | 0    | 0              | 44   | 26    | 0    | 172        |
| 07:15         | 0                                      | 6    | 0     | 0    | 7              | 84   | 0     | 0    | 18                                     | 2    | 0     | 0    | 0              | 41   | 33    | 0    | 191        |
| 07:30         | 1                                      | 5    | 0     | 0    | 12             | 85   | 1     | 0    | 8                                      | 0    | 1     | 0    | 0              | 36   | 27    | 0    | 176        |
| 07:45         | 0                                      | 5    | 1     | 0    | 36             | 108  | 0     | 0    | 15                                     | 1    | 0     | 0    | 1              | 59   | 54    | 0    | 280        |
| Total         | 2                                      | 19   | 1     | 0    | 57             | 362  | 1     | 0    | 51                                     | 4    | 1     | 0    | 1              | 180  | 140   | 0    | 819        |
| 08:00         | 0                                      | 5    | 0     | 0    | 11             | 82   | 0     | 0    | 11                                     | 1    | 3     | 0    | 0              | 42   | 37    | 0    | 192        |
| 08:15         | 0                                      | 1    | 0     | 0    | 5              | 89   | 0     | 0    | 16                                     | 0    | 2     | 0    | 1              | 37   | 26    | 0    | 177        |
| 08:30         | 0                                      | 4    | 0     | 0    | 0              | 74   | 1     | 0    | 16                                     | 0    | 1     | 0    | 0              | 37   | 26    | 0    | 159        |
| 08:45         | 0                                      | 3    | 0     | 0    | 1              | 80   | 0     | 0    | 12                                     | 0    | 0     | 0    | 0              | 50   | 21    | 0    | 167        |
| Total         | 0                                      | 13   | 0     | 0    | 17             | 325  | 1     | 0    | 55                                     | 1    | 6     | 0    | 1              | 166  | 110   | 0    | 695        |
| *** BREAK *** |  |      |       |      |                |      |       |      |  |      |       |      |                |      |       |      |            |
| 15:00         | 0                                      | 2    | 0     | 0    | 2              | 84   | 0     | 0    | 21                                     | 6    | 6     | 0    | 0              | 115  | 14    | 0    | 250        |
| 15:15         | 0                                      | 0    | 1     | 0    | 1              | 65   | 1     | 0    | 21                                     | 7    | 9     | 0    | 0              | 100  | 22    | 0    | 227        |
| 15:30         | 0                                      | 2    | 0     | 0    | 0              | 55   | 1     | 0    | 23                                     | 4    | 13    | 0    | 2              | 84   | 11    | 0    | 195        |
| 15:45         | 0                                      | 0    | 0     | 0    | 5              | 55   | 1     | 0    | 17                                     | 0    | 6     | 0    | 0              | 89   | 9     | 0    | 182        |
| Total         | 0                                      | 4    | 1     | 0    | 8              | 259  | 3     | 0    | 82                                     | 17   | 34    | 0    | 2              | 388  | 56    | 0    | 854        |
| 16:00         | 1                                      | 0    | 0     | 0    | 2              | 88   | 1     | 0    | 24                                     | 6    | 5     | 0    | 1              | 110  | 13    | 0    | 251        |
| 16:15         | 0                                      | 0    | 0     | 0    | 3              | 76   | 0     | 0    | 28                                     | 5    | 7     | 0    | 1              | 111  | 14    | 0    | 245        |
| 16:30         | 0                                      | 1    | 1     | 0    | 2              | 68   | 0     | 0    | 65                                     | 12   | 21    | 0    | 3              | 131  | 12    | 0    | 316        |
| 16:45         | 0                                      | 1    | 0     | 0    | 6              | 73   | 0     | 0    | 39                                     | 6    | 12    | 0    | 2              | 123  | 17    | 0    | 279        |
| Total         | 1                                      | 2    | 1     | 0    | 13             | 305  | 1     | 0    | 156                                    | 29   | 45    | 0    | 7              | 475  | 56    | 0    | 1091       |
| 17:00         | 0                                      | 3    | 1     | 0    | 0              | 69   | 2     | 0    | 41                                     | 4    | 4     | 0    | 1              | 121  | 21    | 0    | 267        |
| 17:15         | 0                                      | 1    | 0     | 0    | 0              | 69   | 0     | 0    | 22                                     | 3    | 5     | 0    | 0              | 106  | 14    | 0    | 220        |
| 17:30         | 1                                      | 2    | 0     | 0    | 0              | 66   | 3     | 0    | 20                                     | 7    | 5     | 0    | 0              | 129  | 8     | 0    | 241        |
| 17:45         | 0                                      | 1    | 0     | 0    | 2              | 54   | 0     | 0    | 24                                     | 3    | 7     | 0    | 0              | 108  | 15    | 0    | 214        |
| Total         | 1                                      | 7    | 1     | 0    | 2              | 258  | 5     | 0    | 107                                    | 17   | 21    | 0    | 1              | 464  | 58    | 0    | 942        |
| Grand Total   | 4                                      | 71   | 4     | 0    | 122            | 1897 | 13    | 0    | 484                                    | 70   | 110   | 0    | 12             | 1776 | 506   | 0    | 5069       |
| Apprch %      | 5.1                                    | 89.9 | 5.1   | 0    | 6              | 93.4 | 0.6   | 0    | 72.9                                   | 10.5 | 16.6  | 0    | 0.5            | 77.4 | 22.1  | 0    |            |
| Total %       | 0.1                                    | 1.4  | 0.1   | 0    | 2.4            | 37.4 | 0.3   | 0    | 9.5                                    | 1.4  | 2.2   | 0    | 0.2            | 35   | 10    | 0    |            |



# MINNESOTA DEPT OF TRANSPORTATION

## TRAFFIC DATA COLLECTION - METRO

TH-8 AT PLEASANT VALLEY RD/CSAH-26&82 File Name : TH-8 AT PLEASANT VALLEY RD 2006  
 REF.PT.: 014.327 Site Code : 00000000  
 JAMAR # 631 RE Start Date : 8/30/2006  
 TURN MOVEMENT COUNT Page No : 2

| Start Time   | PLEASANT VALLEY RD /CSAH-82 Southbound |      |       |      |            | TH-8 Westbound |      |       |      |            | PLEASANT VALLEY RD /CSAH-26 Northbound |      |       |      |            | TH-8 Eastbound |      |       |      |            | Int. Total |
|--|--|------|-------|------|------------|----------------|------|-------|------|------------|--|------|-------|------|------------|----------------|------|-------|------|------------|------------|
|  | Left                                   | Thru | Right | Peds | App. Total | Left           | Thru | Right | Peds | App. Total | Left                                   | Thru | Right | Peds | App. Total | Left           | Thru | Right | Peds | App. Total |            |
| Peak Hour Analysis From 06:00 to 08:45 - Peak 1 of 1 |  |      |       |      |            |                |      |       |      |            |  |      |       |      |            |                |      |       |      |            |            |
| Peak Hour for Entire Intersection Begins at 07:15    |  |      |       |      |            |                |      |       |      |            |  |      |       |      |            |                |      |       |      |            |            |
| 07:15  | 0                                      | 6    | 0     | 0    | 6          | 7              | 84   | 0     | 0    | 91         | 18                                     | 2    | 0     | 0    | 20         | 0              | 41   | 33    | 0    | 74         | 191        |
| 07:30  | 1                                      | 5    | 0     | 0    | 6          | 12             | 85   | 1     | 0    | 98         | 8                                      | 0    | 1     | 0    | 9          | 0              | 36   | 27    | 0    | 63         | 176        |
| 07:45  | 0                                      | 5    | 1     | 0    | 6          | 36             | 108  | 0     | 0    | 144        | 15                                     | 1    | 0     | 0    | 16         | 1              | 59   | 54    | 0    | 114        | 280        |
| 08:00  | 0                                      | 5    | 0     | 0    | 5          | 11             | 82   | 0     | 0    | 93         | 11                                     | 1    | 3     | 0    | 15         | 0              | 42   | 37    | 0    | 79         | 192        |
| Total Volume   | 1                                      | 21   | 1     | 0    | 23         | 66             | 359  | 1     | 0    | 426        | 52                                     | 4    | 4     | 0    | 60         | 1              | 178  | 151   | 0    | 330        | 839        |
| % App. Total   | 4.3                                    | 91.3 | 4.3   | 0    |            | 15.5           | 84.3 | 0.2   | 0    |            | 86.7                                   | 6.7  | 6.7   | 0    |            | 0.3            | 53.9 | 45.8  | 0    |            |            |
| PHF  | .250                                   | .875 | .250  | .000 | .958       | .458           | .831 | .250  | .000 | .740       | .722                                   | .500 | .333  | .000 | .750       | .250           | .754 | .699  | .000 | .724       | .749       |

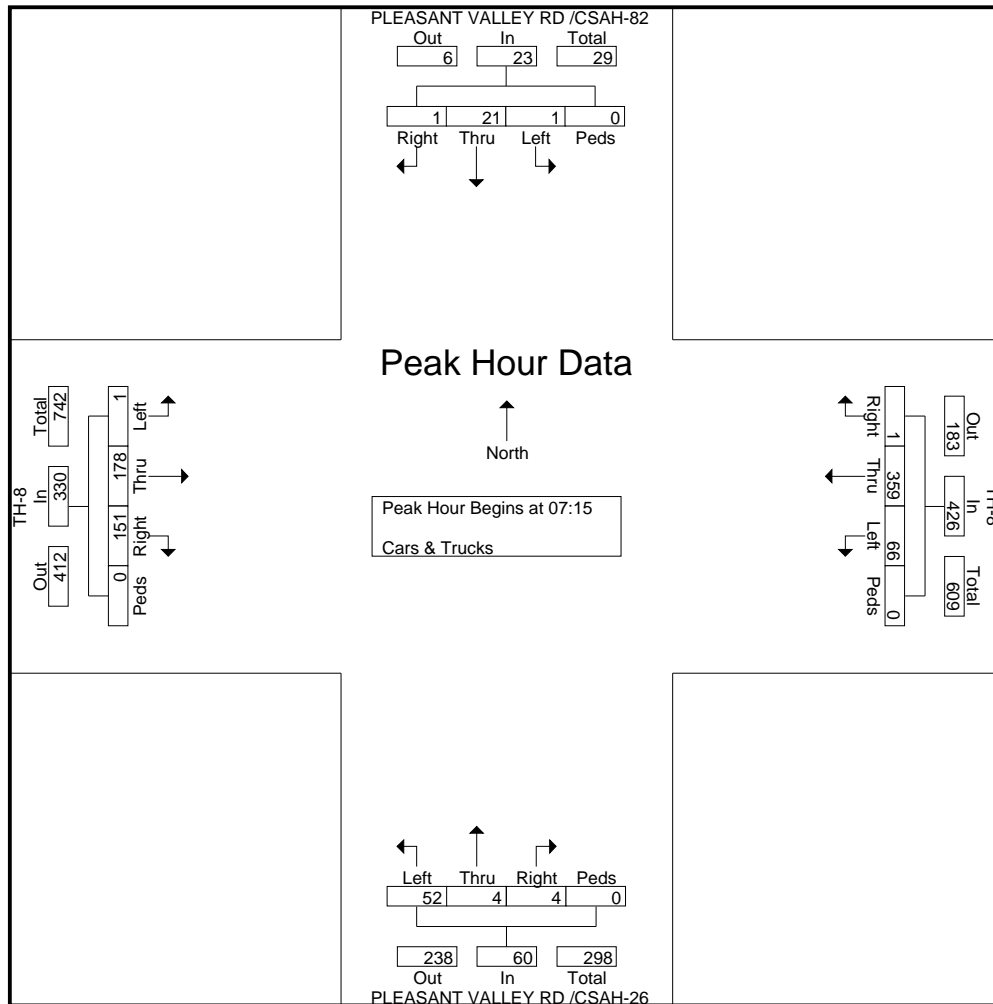



# MINNESOTA DEPT OF TRANSPORTATION

TRAFFIC DATA COLLECTION - METRO

TH-8 AT PLEASANT VALLEY RD/CSAH-26&82 File Name : TH-8 AT PLEASANT VALLEY RD 2006  
 REF.PT.: 014.327 Site Code : 00000000  
 JAMAR # 631 RE Start Date : 8/30/2006  
 TURN MOVEMENT COUNT Page No : 3

| Start Time   | PLEASANT VALLEY RD /CSAH-82 Southbound |      |       |      |            | TH-8 Westbound |      |       |      |            | PLEASANT VALLEY RD /CSAH-26 Northbound |      |       |      |            | TH-8 Eastbound |      |       |      |            | Int. Total |
|--|--|------|-------|------|------------|----------------|------|-------|------|------------|--|------|-------|------|------------|----------------|------|-------|------|------------|------------|
|  | Left                                   | Thru | Right | Peds | App. Total | Left           | Thru | Right | Peds | App. Total | Left                                   | Thru | Right | Peds | App. Total | Left           | Thru | Right | Peds | App. Total |            |
| Peak Hour Analysis From 15:00 to 17:45 - Peak 1 of 1 |  |      |       |      |            |                |      |       |      |            |  |      |       |      |            |                |      |       |      |            |            |
| Peak Hour for Entire Intersection Begins at 16:15    |  |      |       |      |            |                |      |       |      |            |  |      |       |      |            |                |      |       |      |            |            |
| 16:15  | 0                                      | 0    | 0     | 0    | 0          | 3              | 76   | 0     | 0    | 79         | 28                                     | 5    | 7     | 0    | 40         | 1              | 111  | 14    | 0    | 126        | 245        |
| 16:30  | 0                                      | 1    | 1     | 0    | 2          | 2              | 68   | 0     | 0    | 70         | 65                                     | 12   | 21    | 0    | 98         | 3              | 131  | 12    | 0    | 146        | 316        |
| 16:45  | 0                                      | 1    | 0     | 0    | 1          | 6              | 73   | 0     | 0    | 79         | 39                                     | 6    | 12    | 0    | 57         | 2              | 123  | 17    | 0    | 142        | 279        |
| 17:00  | 0                                      | 3    | 1     | 0    | 4          | 0              | 69   | 2     | 0    | 71         | 41                                     | 4    | 4     | 0    | 49         | 1              | 121  | 21    | 0    | 143        | 267        |
| Total Volume   | 0                                      | 5    | 2     | 0    | 7          | 11             | 286  | 2     | 0    | 299        | 173                                    | 27   | 44    | 0    | 244        | 7              | 486  | 64    | 0    | 557        | 1107       |
| % App. Total   | 0                                      | 71.4 | 28.6  | 0    |            | 3.7            | 95.7 | 0.7   | 0    |            | 70.9                                   | 11.1 | 18    | 0    |            | 1.3            | 87.3 | 11.5  | 0    |            |            |
| PHF  | .000                                   | .417 | .500  | .000 | .438       | .458           | .941 | .250  | .000 | .946       | .665                                   | .563 | .524  | .000 | .622       | .583           | .927 | .762  | .000 | .954       | .876       |

