



MINNESOTA DEPT OF TRANSPORTATION

TRAFFIC DATA COLLECTION - METRO

TH-7 at Wooddale Ave.
 ref.pt.: 193.705
 collected by: ALLIANT CONSULT.
 TURN MOVEMENT COUNT

File Name : TH-7 at Wooddale Ave 2007
 Site Code : 00000166
 Start Date : 12/12/2007
 Page No : 1

Groups Printed- Cars & Trucks

Start Time	Wooddale Ave Southbound				TH-7 Westbound				Wooddale Ave Northbound				TH-7 Eastbound				Int. Total
	Left	Thru	Right	Peds	Left	Thru	Right	Peds	Left	Thru	Right	Peds	Left	Thru	Right	Peds	
06:00	3	7	0	0	5	58	3	0	2	2	1	0	2	68	19	0	170
06:15	4	10	2	0	23	109	11	0	2	2	1	0	6	89	22	0	281
06:30	6	23	4	0	41	131	7	0	12	7	4	0	4	146	38	0	423
06:45	12	22	1	0	36	193	11	0	7	9	5	0	29	116	63	0	504
Total	25	62	7	0	105	491	32	0	23	20	11	0	41	419	142	0	1378
07:00	8	22	4	0	24	179	9	0	15	20	4	0	12	180	45	0	522
07:15	13	45	7	0	28	169	23	0	15	37	12	0	25	265	69	0	708
07:30	17	60	7	0	11	231	22	0	25	79	2	0	33	361	62	0	910
07:45	17	79	7	0	16	261	12	0	45	62	9	0	25	374	106	0	1013
Total	55	206	25	0	79	840	66	0	100	198	27	0	95	1180	282	0	3153
08:00	15	26	7	0	19	211	17	0	45	37	4	0	18	310	63	0	772
08:15	14	41	12	0	16	219	13	0	36	46	10	0	27	327	85	0	846
08:30	17	56	10	0	16	193	24	0	33	51	10	0	17	273	72	0	772
08:45	11	45	11	0	9	211	16	0	21	30	5	0	12	263	61	0	695
Total	57	168	40	0	60	834	70	0	135	164	29	0	74	1173	281	0	3085
09:00	7	42	7	0	16	149	18	0	31	24	12	0	15	217	57	0	595
09:15	16	17	6	0	7	165	13	0	18	30	4	0	9	175	34	0	494
*** BREAK ***																	
Total	23	59	13	0	23	314	31	0	49	54	16	0	24	392	91	0	1089
*** BREAK ***																	
10:30	4	27	4	0	13	133	9	0	27	19	6	0	6	141	43	0	432
10:45	9	27	5	0	11	189	11	0	35	20	5	0	8	172	48	0	540
Total	13	54	9	0	24	322	20	0	62	39	11	0	14	313	91	0	972
11:00	17	21	2	0	15	141	13	0	33	31	14	0	9	154	44	0	494
11:15	8	32	7	0	6	171	10	0	37	30	2	0	12	163	65	0	543
11:30	20	41	9	0	15	208	17	0	42	30	6	0	12	174	51	0	625
11:45	13	37	11	0	12	224	13	0	33	32	7	0	12	171	45	0	610
Total	58	131	29	0	48	744	53	0	145	123	29	0	45	662	205	0	2272
12:00	12	34	5	0	9	190	17	0	51	40	12	0	12	170	44	0	596
12:15	11	30	8	0	10	192	23	1	35	31	14	0	15	180	41	0	591
12:30	28	45	9	0	5	167	6	0	54	34	5	0	13	184	54	0	604
12:45	17	31	14	0	16	186	9	0	36	38	4	0	9	218	43	0	621
Total	68	140	36	0	40	735	55	1	176	143	35	0	49	752	182	0	2412
13:00	23	28	16	0	7	190	15	0	48	24	5	0	17	163	48	0	584
13:15	6	41	3	0	19	198	11	0	33	14	7	0	10	137	49	0	528
*** BREAK ***																	
Total	29	69	19	0	26	388	26	0	81	38	12	0	27	300	97	0	1112
*** BREAK ***																	
14:30	11	44	11	0	17	229	23	0	61	39	16	0	26	224	38	0	739
14:45	12	75	9	0	16	237	26	0	54	48	5	0	17	200	42	0	741
Total	23	119	20	0	33	466	49	0	115	87	21	0	43	424	80	0	1480
15:00	11	36	16	0	12	223	40	0	43	38	5	0	30	279	42	0	775
15:15	20	57	16	0	6	256	22	0	52	45	13	0	15	240	48	0	790
15:30	12	40	11	0	19	230	6	0	66	50	4	0	16	279	56	0	789
15:45	13	50	4	0	16	263	13	0	44	35	11	0	10	296	55	0	810
Total	56	183	47	0	53	972	81	0	205	168	33	0	71	1094	201	0	3164



MINNESOTA DEPT OF TRANSPORTATION

TRAFFIC DATA COLLECTION - METRO

TH-7 at Wooddale Ave.
 ref.pt.: 193.705
 collected by: ALLIANT CONSULT.
 TURN MOVEMENT COUNT

File Name : TH-7 at Wooddale Ave 2007
 Site Code : 00000166
 Start Date : 12/12/2007
 Page No : 2

Groups Printed- Cars & Trucks

Start Time	Wooddale Ave Southbound				TH-7 Westbound				Wooddale Ave Northbound				TH-7 Eastbound				Int. Total
	Left	Thru	Right	Peds	Left	Thru	Right	Peds	Left	Thru	Right	Peds	Left	Thru	Right	Peds	
16:00	12	40	20	0	20	226	12	0	64	56	27	0	20	343	60	0	900
16:15	7	40	19	0	15	284	14	0	56	52	22	0	18	349	66	0	942
16:30	18	53	15	0	20	276	9	0	61	45	14	0	20	332	66	0	929
16:45	12	58	19	0	14	270	6	0	72	58	5	0	18	335	72	0	939
Total	49	191	73	0	69	1056	41	0	253	211	68	0	76	1359	264	0	3710
17:00	20	62	17	0	14	244	71	0	74	60	17	0	26	343	89	0	1037
17:15	16	52	11	0	18	286	8	0	63	63	11	0	19	353	86	0	986
17:30	25	44	15	0	26	244	14	0	49	74	7	1	18	330	77	0	924
17:45	18	60	28	0	33	278	17	0	64	58	8	0	29	315	104	0	1012
Total	79	218	71	0	91	1052	110	0	250	255	43	1	92	1341	356	0	3959
Grand Total	535	1600	389	0	651	8214	634	1	1594	1500	335	1	651	9409	2272	0	27786
Apprch %	21.2	63.4	15.4	0	6.9	86.5	6.7	0	46.5	43.7	9.8	0	5.3	76.3	18.4	0	
Total %	1.9	5.8	1.4	0	2.3	29.6	2.3	0	5.7	5.4	1.2	0	2.3	33.9	8.2	0	



MINNESOTA DEPT OF TRANSPORTATION

TRAFFIC DATA COLLECTION - METRO

TH-7 at Wooddale Ave.
 ref.pt.: 193.705
 collected by: ALLIANT CONSULT.
 TURN MOVEMENT COUNT

File Name : TH-7 at Wooddale Ave 2007
 Site Code : 00000166
 Start Date : 12/12/2007
 Page No : 3

Start Time	Wooddale Ave Southbound					TH-7 Westbound					Wooddale Ave Northbound					TH-7 Eastbound					Int. Total
	Left	Thru	Right	Peds	App. Total	Left	Thru	Right	Peds	App. Total	Left	Thru	Right	Peds	App. Total	Left	Thru	Right	Peds	App. Total	
Peak Hour Analysis From 06:00 to 09:15 - Peak 1 of 1																					
Peak Hour for Entire Intersection Begins at 07:30																					
07:30	17	60	7	0	84	11	231	22	0	264	25	79	2	0	106	33	361	62	0	456	910
07:45	17	79	7	0	103	16	261	12	0	289	45	62	9	0	116	25	374	106	0	505	1013
08:00	15	26	7	0	48	19	211	17	0	247	45	37	4	0	86	18	310	63	0	391	772
08:15	14	41	12	0	67	16	219	13	0	248	36	46	10	0	92	27	327	85	0	439	846
Total Volume	63	206	33	0	302	62	922	64	0	1048	151	224	25	0	400	103	1372	316	0	1791	3541
% App. Total	20.9	68.2	10.9	0		5.9	88	6.1	0		37.8	56	6.2	0		5.8	76.6	17.6	0		
PHF	.926	.652	.688	.000	.733	.816	.883	.727	.000	.907	.839	.709	.625	.000	.862	.780	.917	.745	.000	.887	.874

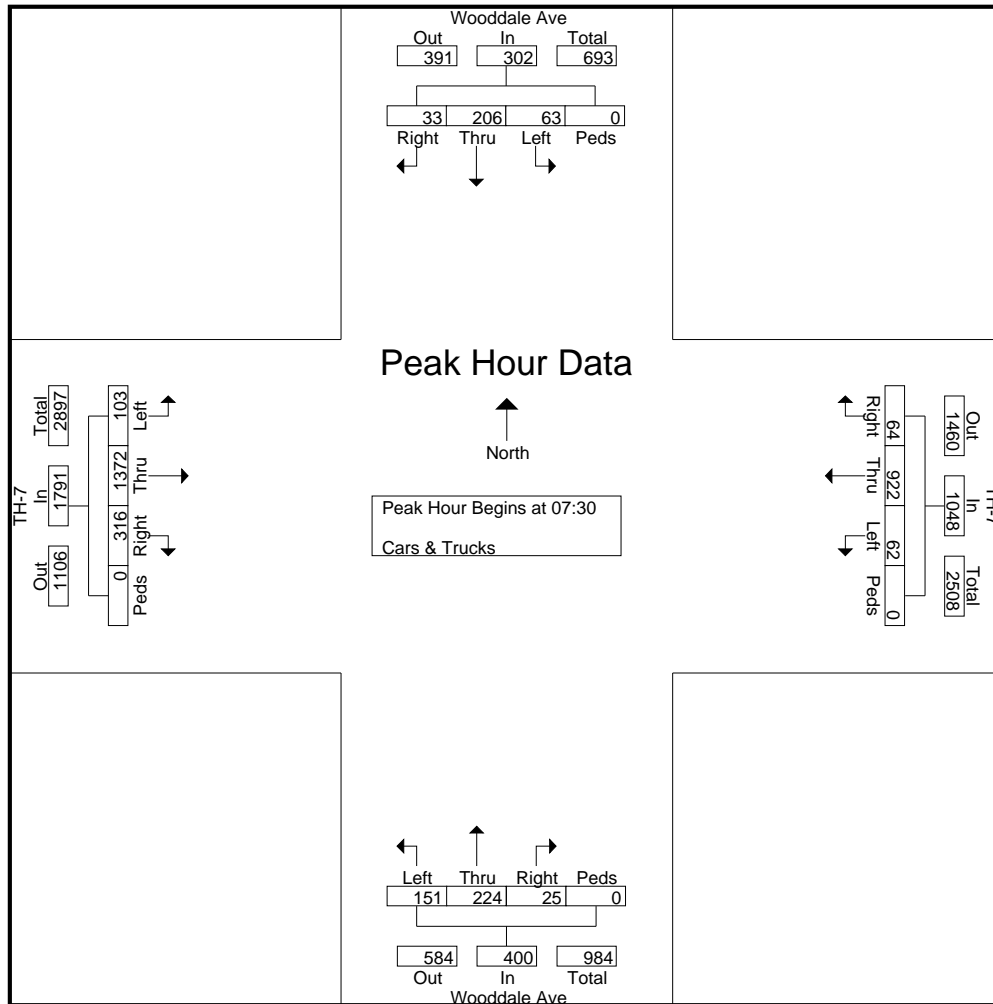



MINNESOTA DEPT OF TRANSPORTATION

TRAFFIC DATA COLLECTION - METRO

TH-7 at Wooddale Ave.
 ref.pt.: 193.705
 collected by: ALLIANT CONSULT.
 TURN MOVEMENT COUNT

File Name : TH-7 at Wooddale Ave 2007
 Site Code : 00000166
 Start Date : 12/12/2007
 Page No : 4

Start Time	Wooddale Ave Southbound					TH-7 Westbound					Wooddale Ave Northbound					TH-7 Eastbound					Int. Total
	Left	Thru	Right	Peds	App. Total	Left	Thru	Right	Peds	App. Total	Left	Thru	Right	Peds	App. Total	Left	Thru	Right	Peds	App. Total	
Peak Hour Analysis From 14:30 to 17:45 - Peak 1 of 1																					
Peak Hour for Entire Intersection Begins at 17:00																					
17:00	20	62	17	0	99	14	244	71	0	329	74	60	17	0	151	26	343	89	0	458	1037
17:15	16	52	11	0	79	18	286	8	0	312	63	63	11	0	137	19	353	86	0	458	986
17:30	25	44	15	0	84	26	244	14	0	284	49	74	7	1	131	18	330	77	0	425	924
17:45	18	60	28	0	106	33	278	17	0	328	64	58	8	0	130	29	315	104	0	448	1012
Total Volume	79	218	71	0	368	91	1052	110	0	1253	250	255	43	1	549	92	1341	356	0	1789	3959
% App. Total	21.5	59.2	19.3	0		7.3	84	8.8	0		45.5	46.4	7.8	0.2		5.1	75	19.9	0		
PHF	.790	.879	.634	.000	.868	.689	.920	.387	.000	.952	.845	.861	.632	.250	.909	.793	.950	.856	.000	.977	.954

