



MINNESOTA DEPT OF TRANSPORTATION

TRAFFIC DATA COLLECTION - METRO

Louisiana Ave at Walker St.,
 ref.pt. St Louis Park
 collected by: ALLIANT CONSULT.
 TURN MOVEMENT COUNT

File Name : Louisiana Ave at Walker St 2007
 Site Code : 00000163
 Start Date : 12/13/2007
 Page No : 1

Groups Printed- Unshifted

Start Time	Louisiana Ave Southbound				Walker St Westbound				Louisiana Ave Northbound				Walker St Eastbound				Int. Total
	Left	Thru	Right	Peds	Left	Thru	Right	Peds	Left	Thru	Right	Peds	Left	Thru	Right	Peds	
06:00	1	20	3	0	1	0	0	0	2	4	9	0	0	5	12	0	57
06:15	2	25	0	0	2	1	1	0	2	18	6	0	3	4	10	0	74
06:30	3	51	1	0	3	0	0	0	0	25	10	0	1	5	15	0	114
06:45	3	55	2	0	3	3	0	0	4	23	10	0	1	15	25	0	144
Total	9	151	6	0	9	4	1	0	8	70	35	0	5	29	62	0	389
07:00	3	56	4	0	3	2	1	0	5	21	12	0	2	10	24	0	143
07:15	4	73	2	0	2	2	1	0	5	57	26	0	8	24	27	0	231
07:30	2	88	7	0	2	3	3	0	4	60	23	0	10	27	31	0	260
07:45	9	106	9	0	9	11	2	0	6	87	23	0	11	24	30	0	327
Total	18	323	22	0	16	18	7	0	20	225	84	0	31	85	112	0	961
08:00	10	83	8	0	2	4	6	0	4	58	13	0	10	16	28	0	242
08:15	6	84	5	0	5	6	2	0	5	64	20	0	3	13	30	0	243
08:30	13	63	7	0	3	10	0	0	8	43	8	0	5	19	23	0	202
08:45	1	69	5	0	7	9	3	0	3	56	18	0	8	9	15	0	203
Total	30	299	25	0	17	29	11	0	20	221	59	0	26	57	96	0	890
09:00	7	55	5	0	9	10	2	0	9	45	18	0	9	8	12	0	189
09:15	3	57	5	0	3	5	2	0	8	47	9	0	9	17	9	0	174
*** BREAK ***																	
Total	10	112	10	0	12	15	4	0	17	92	27	0	18	25	21	0	363
*** BREAK ***																	
10:30	6	49	6	0	8	11	3	0	7	46	15	0	6	10	9	0	176
10:45	5	66	5	0	5	7	7	0	4	39	22	0	8	9	9	0	186
Total	11	115	11	0	13	18	10	0	11	85	37	0	14	19	18	0	362
11:00	6	51	6	0	10	7	7	0	8	52	13	0	10	14	5	0	189
11:15	5	66	7	0	7	10	5	0	9	49	21	0	8	8	9	0	204
11:30	2	60	5	0	5	10	6	0	15	61	19	0	9	14	8	0	214
11:45	3	65	12	0	11	11	3	0	10	68	15	0	2	10	12	0	222
Total	16	242	30	0	33	38	21	0	42	230	68	0	29	46	34	0	829
12:00	2	67	7	0	3	15	5	0	9	74	14	0	7	15	7	0	225
12:15	4	56	16	0	8	8	2	0	9	86	29	0	10	18	11	0	257
12:30	6	62	15	0	8	5	3	0	4	97	16	0	15	16	14	0	261
12:45	2	57	17	0	4	5	10	0	11	116	24	0	6	22	6	0	280
Total	14	242	55	0	23	33	20	0	33	373	83	0	38	71	38	0	1023
13:00	4	54	8	0	7	9	5	0	5	99	16	0	11	12	5	0	235
13:15	8	70	13	0	16	6	2	0	5	74	20	0	9	16	7	0	246
*** BREAK ***																	
Total	12	124	21	0	23	15	7	0	10	173	36	0	20	28	12	0	481
*** BREAK ***																	
14:30	4	72	12	0	0	0	0	0	0	0	0	0	14	23	11	0	136
14:45	7	87	14	0	15	16	3	0	13	80	17	1	12	19	17	0	301
Total	11	159	26	0	15	16	3	0	13	80	17	1	26	42	28	0	437
15:00	2	65	10	0	9	13	6	0	14	76	24	0	12	25	7	0	263
15:15	3	77	11	0	16	15	3	0	15	84	18	0	14	11	5	0	272
15:30	1	65	15	0	12	18	4	0	10	103	14	0	18	19	8	0	287
15:45	2	66	14	0	10	13	6	0	18	94	22	0	11	18	10	0	284
Total	8	273	50	0	47	59	19	0	57	357	78	0	55	73	30	0	1106



MINNESOTA DEPT OF TRANSPORTATION

TRAFFIC DATA COLLECTION - METRO

Louisiana Ave at Walker St.,
 ref.pt. St Louis Park
 collected by: ALLIANT CONSULT.
 TURN MOVEMENT COUNT

File Name : Louisiana Ave at Walker St 2007
 Site Code : 00000163
 Start Date : 12/13/2007
 Page No : 2

Groups Printed- Unshifted

Start Time	Louisiana Ave Southbound				Walker St Westbound				Louisiana Ave Northbound				Walker St Eastbound				Int. Total
	Left	Thru	Right	Peds	Left	Thru	Right	Peds	Left	Thru	Right	Peds	Left	Thru	Right	Peds	
16:00	5	94	9	0	13	11	9	0	22	108	15	0	16	17	12	0	331
16:15	7	78	9	0	10	16	9	0	26	113	13	0	9	23	12	0	325
16:30	4	92	12	0	4	13	4	0	21	129	23	0	12	18	13	0	345
16:45	7	135	12	0	12	12	4	0	25	117	20	0	14	17	13	0	388
Total	23	399	42	0	39	52	26	0	94	467	71	0	51	75	50	0	1389
17:00	5	97	15	0	14	16	5	0	24	120	18	0	10	24	16	0	364
17:15	6	115	18	0	11	13	8	0	34	116	26	0	17	13	13	0	390
17:30	5	148	18	0	8	11	5	0	33	141	15	0	15	24	7	0	430
17:45	6	132	12	0	6	29	9	0	29	91	22	3	15	34	9	0	397
Total	22	492	63	0	39	69	27	0	120	468	81	3	57	95	45	0	1581
Grand Total	184	2931	361	0	286	366	156	0	445	2841	676	4	370	645	546	0	9811
Apprch %	5.3	84.3	10.4	0	35.4	45.3	19.3	0	11.2	71.6	17	0.1	23.7	41.3	35	0	
Total %	1.9	29.9	3.7	0	2.9	3.7	1.6	0	4.5	29	6.9	0	3.8	6.6	5.6	0	



MINNESOTA DEPT OF TRANSPORTATION

TRAFFIC DATA COLLECTION - METRO

Louisiana Ave at Walker St.,
 ref.pt. St Louis Park
 collected by: ALLIANT CONSULT.
 TURN MOVEMENT COUNT

File Name : Louisiana Ave at Walker St 2007
 Site Code : 00000163
 Start Date : 12/13/2007
 Page No : 3

Start Time	Louisiana Ave Southbound					Walker St Westbound					Louisiana Ave Northbound					Walker St Eastbound					Int. Total
	Left	Thru	Right	Peds	App. Total	Left	Thru	Right	Peds	App. Total	Left	Thru	Right	Peds	App. Total	Left	Thru	Right	Peds	App. Total	
Peak Hour Analysis From 06:00 to 09:15 - Peak 1 of 1																					
Peak Hour for Entire Intersection Begins at 07:30																					
07:30	2	88	7	0	97	2	3	3	0	8	4	60	23	0	87	10	27	31	0	68	260
07:45	9	106	9	0	124	9	11	2	0	22	6	87	23	0	116	11	24	30	0	65	327
08:00	10	83	8	0	101	2	4	6	0	12	4	58	13	0	75	10	16	28	0	54	242
08:15	6	84	5	0	95	5	6	2	0	13	5	64	20	0	89	3	13	30	0	46	243
Total Volume	27	361	29	0	417	18	24	13	0	55	19	269	79	0	367	34	80	119	0	233	1072
% App. Total																					
PHF	.675	.851	.806	.000	.841	.500	.545	.542	.000	.625	.792	.773	.859	.000	.791	.773	.741	.960	.000	.857	.820

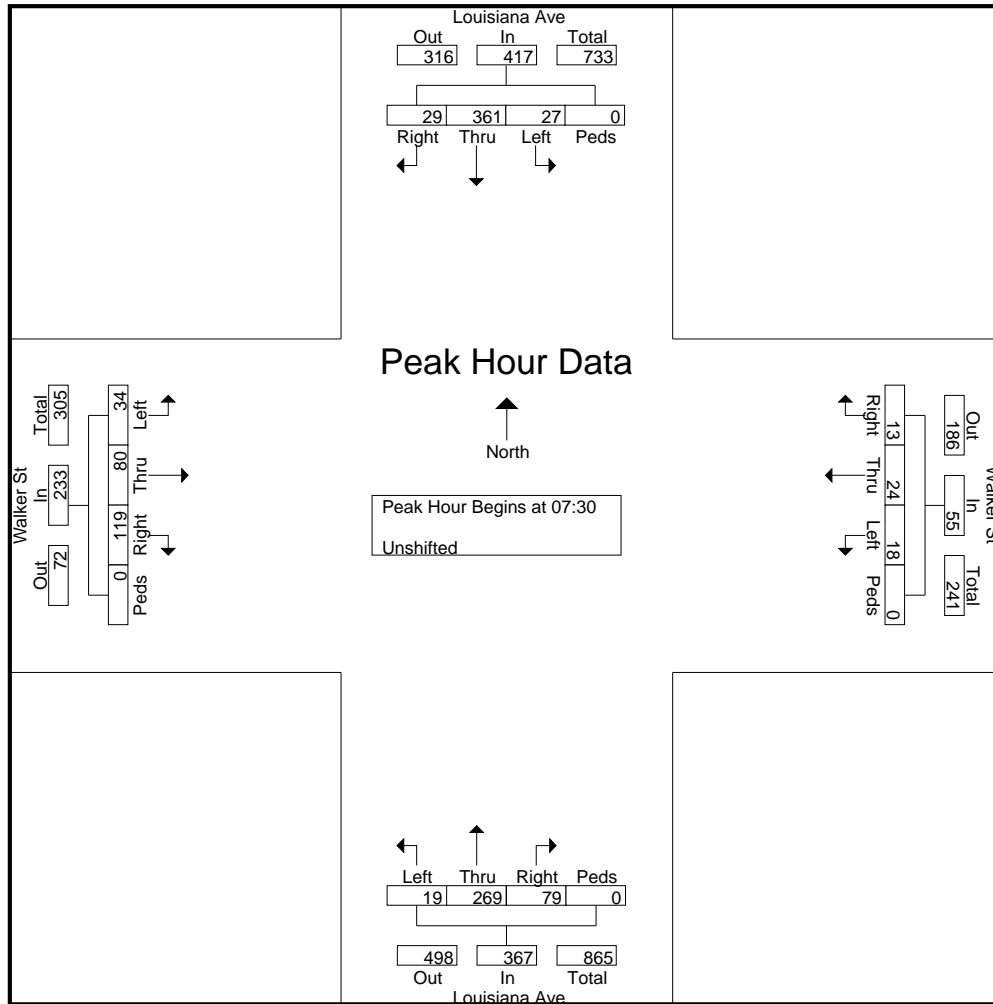



MINNESOTA DEPT OF TRANSPORTATION

TRAFFIC DATA COLLECTION - METRO

Louisiana Ave at Walker St.,
 ref.pt. St Louis Park
 collected by: ALLIANT CONSULT.
 TURN MOVEMENT COUNT

File Name : Louisiana Ave at Walker St 2007
 Site Code : 00000163
 Start Date : 12/13/2007
 Page No : 4

Start Time	Louisiana Ave Southbound					Walker St Westbound					Louisiana Ave Northbound					Walker St Eastbound					Int. Total
	Left	Thru	Right	Peds	App. Total	Left	Thru	Right	Peds	App. Total	Left	Thru	Right	Peds	App. Total	Left	Thru	Right	Peds	App. Total	
Peak Hour Analysis From 14:30 to 17:45 - Peak 1 of 1																					
Peak Hour for Entire Intersection Begins at 17:00																					
17:00	5	97	15	0	117	14	16	5	0	35	24	120	18	0	162	10	24	16	0	50	364
17:15	6	115	18	0	139	11	13	8	0	32	34	116	26	0	176	17	13	13	0	43	390
17:30	5	148	18	0	171	8	11	5	0	24	33	141	15	0	189	15	24	7	0	46	430
17:45	6	132	12	0	150	6	29	9	0	44	29	91	22	3	145	15	34	9	0	58	397
Total Volume	22	492	63	0	577	39	69	27	0	135	120	468	81	3	672	57	95	45	0	197	1581
% App. Total																					
PHF	.917	.831	.875	.000	.844	.696	.595	.750	.000	.767	.882	.830	.779	.250	.889	.838	.699	.703	.000	.849	.919

