

# Alliant Engineering Inc Minneapolis, MN 55415

TH-7 at Blake Ave N / Aquila Ave S  
Ref.Pt.: 192.257  
Alliant Engineering Inc  
TURN MOVEMENT COUNT

File Name : 19\_TH 7 at Blake Rd\_011111  
Site Code : 00000019  
Start Date : 1/11/2011  
Page No : 1

### Groups Printed- Unshifted - Bank 1

Start Time	Aquila Ave S. Southbound				TH-7 Westbound				Blake Rd N / CSAH-20 Northbound				TH-7 Eastbound				Int. Total
	Left	Thru	Right	Peds	Left	Thru	Right	Peds	Left	Thru	Right	Peds	Left	Thru	Right	Peds	
06:00	1	1	0	0	6	31	5	0	14	5	17	0	4	94	9	1	188
06:15	5	3	1	0	27	59	7	0	19	8	20	0	11	133	8	0	301
06:30	7	12	2	0	23	89	3	0	23	8	20	0	21	211	14	0	433
06:45	5	7	0	0	37	120	4	1	31	10	26	0	24	228	17	0	510
Total	18	23	3	0	93	299	19	1	87	31	83	0	60	666	48	1	1432
07:00	6	8	2	0	38	145	3	0	43	8	46	0	17	232	24	0	572
07:15	8	16	1	0	48	161	6	0	32	26	50	0	22	291	31	0	692
07:30	9	12	0	0	64	283	10	0	42	16	42	0	12	343	45	0	878
07:45	13	21	1	0	73	268	7	0	44	28	46	0	42	320	52	0	915
Total	36	57	4	0	223	857	26	0	161	78	184	0	93	1186	152	0	3057
08:00	16	17	1	0	48	228	14	0	34	31	51	0	33	337	30	0	840
08:15	17	18	1	0	59	225	23	0	30	34	75	1	37	283	24	0	827
08:30	18	17	2	0	29	174	22	0	43	37	72	0	47	258	20	1	740
08:45	15	29	1	0	31	190	26	0	38	30	62	0	46	243	30	0	741
Total	66	81	5	0	167	817	85	0	145	132	260	1	163	1121	104	1	3148
09:00	28	21	2	0	23	147	15	0	24	30	56	0	36	185	25	0	592
09:15	25	25	1	0	21	118	22	0	29	32	48	0	49	153	21	2	546
*** BREAK ***																	
Total	53	46	3	0	44	265	37	0	53	62	104	0	85	338	46	2	1138
*** BREAK ***																	
10:30	32	29	2	0	36	123	32	0	36	16	34	1	64	146	18	0	569
10:45	29	39	4	0	43	138	36	1	26	49	32	0	64	133	10	0	604
Total	61	68	6	0	79	261	68	1	62	65	66	1	128	279	28	0	1173
11:00	28	34	5	0	45	165	36	0	41	50	50	0	74	134	24	0	686
11:15	35	48	7	0	30	138	26	0	39	60	54	0	65	129	21	0	652
11:30	31	51	7	0	51	155	29	0	29	52	61	0	104	167	23	0	760
11:45	45	59	2	0	55	184	43	0	53	73	36	0	101	146	26	0	823
Total	139	192	21	0	181	642	134	0	162	235	201	0	344	576	94	0	2921
12:00	37	49	7	0	50	189	37	0	39	69	61	0	110	163	33	0	844
12:15	33	67	3	0	63	159	39	0	52	75	68	0	68	151	26	0	804
12:30	46	53	0	0	59	187	32	0	40	63	73	0	104	171	20	0	848
12:45	62	62	6	0	55	166	33	0	52	73	57	3	86	123	23	0	801
Total	178	231	16	0	227	701	141	0	183	280	259	3	368	608	102	0	3297
13:00	48	45	6	0	43	174	31	0	42	62	53	0	78	152	20	0	754
13:15	45	77	4	0	51	137	24	1	42	60	64	2	67	129	16	0	719
*** BREAK ***																	
Total	93	122	10	0	94	311	55	1	84	122	117	2	145	281	36	0	1473
*** BREAK ***																	
14:30	37	50	19	0	44	186	34	0	37	55	43	1	49	161	28	0	744
14:45	26	48	18	0	52	172	33	0	32	41	60	0	53	192	34	0	761
Total	63	98	37	0	96	358	67	0	69	96	103	1	102	353	62	0	1505
15:00	29	44	24	0	61	215	27	0	40	59	44	0	44	144	31	0	762
15:15	27	57	23	0	40	222	34	1	40	37	50	0	70	176	51	1	829
15:30	33	41	16	0	56	242	39	2	49	39	65	0	53	191	43	2	871
15:45	26	60	18	0	61	269	46	0	45	48	63	0	58	243	43	0	980
Total	115	202	81	0	218	948	146	3	174	183	222	0	225	754	168	3	3442

# Alliant Engineering Inc Minneapolis, MN 55415

TH-7 at Blake Ave N / Aquila Ave S  
 Ref.Pt.: 192.257  
 Alliant Engineering Inc  
 TURN MOVEMENT COUNT

File Name : 19\_TH 7 at Blake Rd\_011111  
 Site Code : 00000019  
 Start Date : 1/11/2011  
 Page No : 2

### Groups Printed- Unshifted - Bank 1

Start Time	Aquila Ave S. Southbound				TH-7 Westbound				Blake Rd N / CSAH-20 Northbound				TH-7 Eastbound				Int. Total
	Left	Thru	Right	Peds	Left	Thru	Right	Peds	Left	Thru	Right	Peds	Left	Thru	Right	Peds	
16:00	37	49	29	0	42	170	28	2	42	58	83	0	80	270	46	0	936
16:15	40	49	31	0	45	208	43	0	50	64	92	0	83	252	37	2	996
16:30	41	60	25	0	49	215	32	1	42	60	81	1	85	276	49	0	1017
16:45	42	74	33	0	58	209	37	0	43	75	93	0	83	313	58	1	1119
Total	160	232	118	0	194	802	140	3	177	257	349	1	331	1111	190	3	4068
17:00	47	77	53	0	66	151	29	3	59	105	97	0	70	344	45	0	1146
17:15	36	56	60	0	70	246	32	2	32	84	93	0	85	390	60	0	1246
17:30	37	60	75	0	54	228	36	0	35	85	110	0	74	395	46	1	1236
17:45	32	55	68	0	71	190	32	2	60	71	73	0	89	338	37	0	1118
Total	152	248	256	0	261	815	129	7	186	345	373	0	318	1467	188	1	4746
Grand Total	1134	1600	560	0	1877	7076	1047	16	1543	1886	2321	9	2362	8740	1218	11	31400
Apprch %	34.4	48.6	17	0	18.7	70.6	10.5	0.2	26.8	32.7	40.3	0.2	19.2	70.9	9.9	0.1	
Total %	3.6	5.1	1.8	0	6	22.5	3.3	0.1	4.9	6	7.4	0	7.5	27.8	3.9	0	
Unshifted	1104	1563	556	0	1843	6923	1020	16	1490	1833	2286	8	2328	8595	1165	10	30740
% Unshifted	97.4	97.7	99.3	0	98.2	97.8	97.4	100	96.6	97.2	98.5	88.9	98.6	98.3	95.6	90.9	97.9
Bank 1	30	37	4	0	34	153	27	0	53	53	35	1	34	145	53	1	660
% Bank 1	2.6	2.3	0.7	0	1.8	2.2	2.6	0	3.4	2.8	1.5	11.1	1.4	1.7	4.4	9.1	2.1

# Alliant Engineering Inc Minneapolis, MN 55415

TH-7 at Blake Ave N / Aquila Ave S  
Ref.Pt.: 192.257  
Alliant Engineering Inc  
TURN MOVEMENT COUNT

File Name : 19\_TH 7 at Blake Rd\_011111  
Site Code : 00000019  
Start Date : 1/11/2011  
Page No : 3

Start Time	Aquila Ave S. Southbound					TH-7 Westbound					Blake Rd N / CSAH-20 Northbound					TH-7 Eastbound					Int. Total
	Left	Thru	Right	Peds	App. Total	Left	Thru	Right	Peds	App. Total	Left	Thru	Right	Peds	App. Total	Left	Thru	Right	Peds	App. Total	
Peak Hour Analysis From 06:00 to 09:15 - Peak 1 of 1																					
Peak Hour for Entire Intersection Begins at 07:30																					
07:30	9	12	0	0	21	64	283	10	0	357	42	16	42	0	100	12	343	45	0	400	878
07:45	13	21	1	0	35	73	268	7	0	348	44	28	46	0	118	42	320	52	0	414	915
08:00	16	17	1	0	34	48	228	14	0	290	34	31	51	0	116	33	337	30	0	400	840
08:15	17	18	1	0	36	59	225	23	0	307	30	34	75	1	140	37	283	24	0	344	827
Total Volume	55	68	3	0	126	244	1004	54	0	1302	150	109	214	1	474	124	1283	151	0	1558	3460
% App. Total	43.7	54	2.4	0		18.7	77.1	4.1	0		31.6	23	45.1	0.2		8	82.3	9.7	0		
PHF	.809	.810	.750	.000	.875	.836	.887	.587	.000	.912	.852	.801	.713	.250	.846	.738	.935	.726	.000	.941	.945

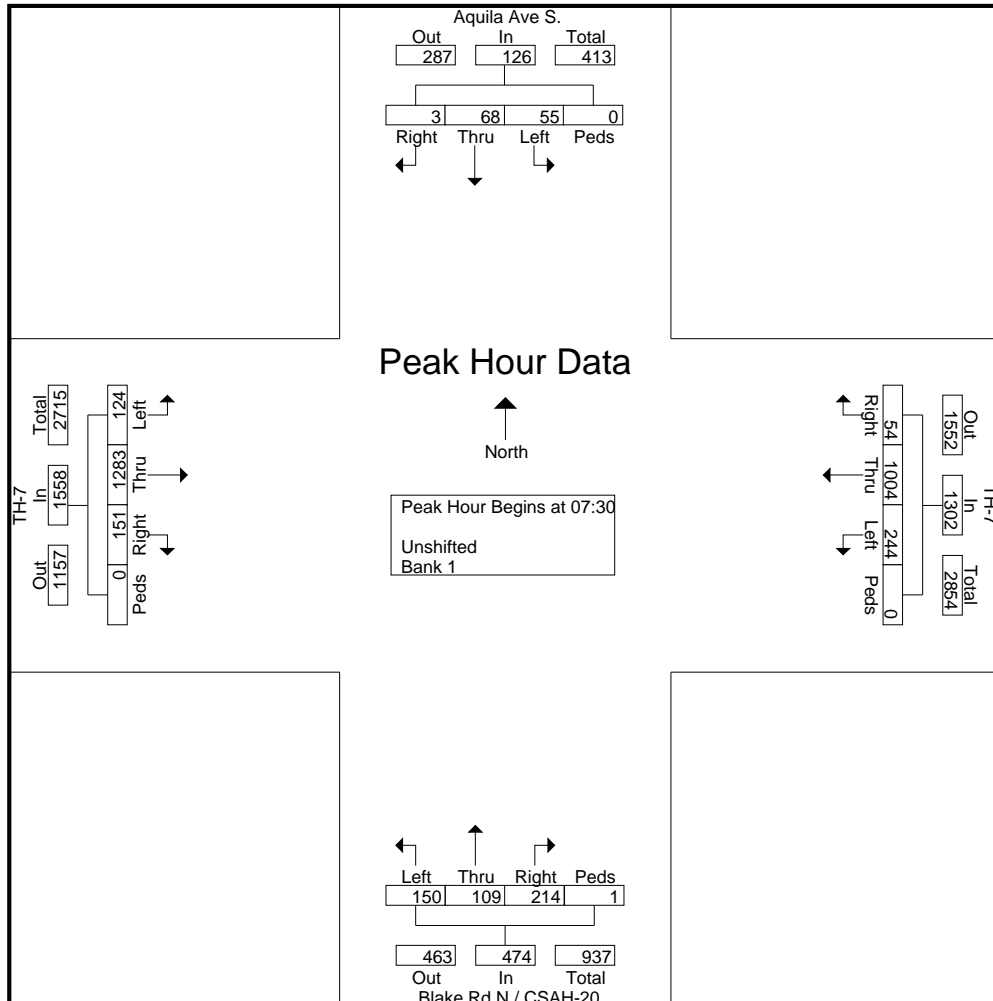

# Alliant Engineering Inc Minneapolis, MN 55415

TH-7 at Blake Ave N / Aquila Ave S  
 Ref.Pt.: 192.257  
 Alliant Engineering Inc  
 TURN MOVEMENT COUNT

File Name : 19\_TH 7 at Blake Rd\_011111  
 Site Code : 00000019  
 Start Date : 1/11/2011  
 Page No : 4

Start Time	Aquila Ave S. Southbound					TH-7 Westbound					Blake Rd N / CSAH-20 Northbound					TH-7 Eastbound					Int. Total
	Left	Thru	Right	Peds	App. Total	Left	Thru	Right	Peds	App. Total	Left	Thru	Right	Peds	App. Total	Left	Thru	Right	Peds	App. Total	
Peak Hour Analysis From 14:30 to 17:45 - Peak 1 of 1																					
Peak Hour for Entire Intersection Begins at 16:45																					
16:45	42	74	33	0	149	58	209	37	0	304	43	75	93	0	211	83	313	58	1	455	1119
17:00	47	77	53	0	177	66	151	29	3	249	59	105	97	0	261	70	344	45	0	459	1146
17:15	36	56	60	0	152	70	246	32	2	350	32	84	93	0	209	85	390	60	0	535	1246
17:30	37	60	75	0	172	54	228	36	0	318	35	85	110	0	230	74	395	46	1	516	1236
Total Volume	162	267	221	0	650	248	834	134	5	1221	169	349	393	0	911	312	1442	209	2	1965	4747
% App. Total	24.9	41.1	34	0		20.3	68.3	11	0.4		18.6	38.3	43.1	0		15.9	73.4	10.6	0.1		
PHF	.862	.867	.737	.000	.918	.886	.848	.905	.417	.872	.716	.831	.893	.000	.873	.918	.913	.871	.500	.918	.952

