



MINNESOTA DEPT OF TRANSPORTATION

TRAFFIC DATA COLLECTION - METRO

TH-7 at Blake Rd N / Aquila Ave S
 ref.pt.: 192.257
 collected by: ALLIANT CONSULT.
 TURN MOVEMENT COUNT

File Name : TH-7 at Blake Rd - Aquila Ave 2007
 Site Code : 00000160
 Start Date : 12/11/2007
 Page No : 1

Groups Printed- Car & Trucks

Start Time	Aquila Ave S Southbound				TH-7 Westbound				Blake Rd N Northbound				TH-7 Eastbound				Int. Total
	Left	Thru	Right	Peds	Left	Thru	Right	Peds	Left	Thru	Right	Peds	Left	Thru	Right	Peds	
06:00	1	2	5	0	8	34	5	0	14	7	13	0	5	81	8	0	183
06:15	4	3	10	0	14	57	5	0	15	6	16	0	9	192	8	0	339
06:30	6	5	12	0	24	81	4	0	30	7	22	0	13	220	12	0	436
06:45	7	11	11	0	20	135	11	0	36	16	25	0	15	230	17	0	534
Total	18	21	38	0	66	307	25	0	95	36	76	0	42	723	45	0	1492
07:00	7	9	18	0	26	142	7	0	29	14	34	0	20	290	24	0	620
07:15	8	19	21	0	29	161	13	0	36	17	44	0	16	375	23	0	762
07:30	13	19	18	0	16	221	13	0	35	13	60	0	27	442	32	0	909
07:45	12	21	33	0	20	329	20	0	46	29	49	0	36	417	35	0	1047
Total	40	68	90	0	91	853	53	0	146	73	187	0	99	1524	114	0	3338
08:00	10	15	11	0	24	190	25	0	38	22	41	0	22	346	46	0	790
08:15	14	19	7	0	27	199	25	0	31	34	63	0	37	312	34	0	802
08:30	19	17	22	0	26	175	19	0	36	28	71	0	37	265	28	0	743
08:45	23	22	17	0	25	182	19	0	27	29	66	0	57	238	27	0	732
Total	66	73	57	0	102	746	88	0	132	113	241	0	153	1161	135	0	3067
09:00	19	13	27	0	21	108	28	0	30	23	60	0	42	196	31	0	598
09:15	15	21	35	0	33	136	34	0	21	37	43	0	68	207	27	0	677
*** BREAK ***																	
Total	34	34	62	0	54	244	62	0	51	60	103	0	110	403	58	0	1275
*** BREAK ***																	
10:30	28	28	30	0	34	127	35	0	44	43	28	0	58	136	25	0	616
10:45	41	36	30	0	33	126	26	0	38	56	31	0	90	167	18	0	692
Total	69	64	60	0	67	253	61	0	82	99	59	0	148	303	43	0	1308
11:00	33	33	49	0	36	139	39	0	30	64	44	0	100	131	24	0	722
11:15	33	55	54	1	53	148	32	0	42	54	45	0	113	168	33	0	831
11:30	44	46	75	0	42	143	35	0	48	67	25	0	101	143	29	0	798
11:45	37	61	47	0	79	146	46	0	29	65	43	0	140	144	39	0	876
Total	147	195	225	1	210	576	152	0	149	250	157	0	454	586	125	0	3227
12:00	45	46	56	0	67	141	49	0	57	94	62	0	120	120	32	0	889
12:15	51	77	76	0	54	155	47	2	50	76	75	1	125	155	30	0	974
12:30	44	77	65	0	54	155	35	0	58	71	54	0	114	132	31	0	890
12:45	56	84	58	0	57	170	37	0	58	70	55	0	117	140	29	0	931
Total	196	284	255	0	232	621	168	2	223	311	246	1	476	547	122	0	3684
13:00	49	77	75	0	53	157	50	0	51	61	42	0	110	150	38	0	913
13:15	52	60	59	0	51	152	39	0	33	57	50	0	107	148	30	0	838
*** BREAK ***																	
Total	101	137	134	0	104	309	89	0	84	118	92	0	217	298	68	0	1751
*** BREAK ***																	
15:00	41	66	95	0	44	223	54	0	47	53	52	0	113	219	25	0	1032
15:15	40	62	104	0	77	245	47	0	46	69	56	0	90	200	36	0	1072
15:30	45	53	103	0	48	235	39	0	45	62	85	0	93	195	26	0	1029
15:45	33	61	88	0	57	310	37	0	48	75	75	0	78	227	31	0	1120
Total	159	242	390	0	226	1013	177	0	186	259	268	0	374	841	118	0	4253
16:00	41	68	74	0	61	237	42	0	54	82	73	0	94	274	49	0	1149
16:15	36	46	94	0	49	213	32	0	58	73	75	0	117	323	42	0	1158
16:30	36	55	94	0	54	292	30	0	43	76	92	0	121	339	37	0	1269
16:45	42	60	92	0	79	271	41	0	47	124	80	0	118	369	48	0	1371
Total	155	229	354	0	243	1013	145	0	202	355	320	0	450	1305	176	0	4947



MINNESOTA DEPT OF TRANSPORTATION

TRAFFIC DATA COLLECTION - METRO

TH-7 at Blake Rd N / Aquila Ave S
 ref.pt.: 192.257
 collected by: ALLIANT CONSULT.
 TURN MOVEMENT COUNT

File Name : TH-7 at Blake Rd - Aquila Ave 2007
 Site Code : 00000160
 Start Date : 12/11/2007
 Page No : 2

Groups Printed- Car & Trucks

Start Time	Aquila Ave S Southbound				TH-7 Westbound				Blake Rd N Northbound				TH-7 Eastbound				Int. Total
	Left	Thru	Right	Peds	Left	Thru	Right	Peds	Left	Thru	Right	Peds	Left	Thru	Right	Peds	
17:00	38	57	93	0	54	281	50	1	56	90	47	0	129	330	40	0	1266
17:15	38	66	100	0	71	264	22	0	53	92	61	0	128	397	40	0	1332
17:30	44	53	77	0	64	256	42	0	45	91	66	0	139	369	56	0	1302
17:45	40	72	85	0	85	249	23	0	61	79	62	0	146	352	45	0	1299
Total	160	248	355	0	274	1050	137	1	215	352	236	0	542	1448	181	0	5199
Grand Total	1145	1595	2020	1	1669	6985	1157	3	1565	2026	1985	1	3065	9139	1185	0	33541
Apprch %	24	33.5	42.4	0	17	71.2	11.8	0	28.1	36.3	35.6	0	22.9	68.3	8.9	0	
Total %	3.4	4.8	6	0	5	20.8	3.4	0	4.7	6	5.9	0	9.1	27.2	3.5	0	



MINNESOTA DEPT OF TRANSPORTATION

TRAFFIC DATA COLLECTION - METRO

TH-7 at Blake Rd N / Aquila Ave S
 ref.pt.: 192.257
 collected by: ALLIANT CONSULT.
 TURN MOVEMENT COUNT

File Name : TH-7 at Blake Rd - Aquila Ave 2007
 Site Code : 00000160
 Start Date : 12/11/2007
 Page No : 3

Start Time	Aquila Ave S Southbound					TH-7 Westbound					Blake Rd N Northbound					TH-7 Eastbound					Int. Total
	Left	Thru	Right	Peds	App. Total	Left	Thru	Right	Peds	App. Total	Left	Thru	Right	Peds	App. Total	Left	Thru	Right	Peds	App. Total	
Peak Hour Analysis From 06:00 to 09:15 - Peak 1 of 1																					
Peak Hour for Entire Intersection Begins at 07:30																					
07:30	13	19	18	0	50	16	221	13	0	250	35	13	60	0	108	27	442	32	0	501	909
07:45	12	21	33	0	66	20	329	20	0	369	46	29	49	0	124	36	417	35	0	488	1047
08:00	10	15	11	0	36	24	190	25	0	239	38	22	41	0	101	22	346	46	0	414	790
08:15	14	19	7	0	40	27	199	25	0	251	31	34	63	0	128	37	312	34	0	383	802
Total Volume	49	74	69	0	192	87	939	83	0	1109	150	98	213	0	461	122	1517	147	0	1786	3548
% App. Total	25.5	38.5	35.9	0		7.8	84.7	7.5	0		32.5	21.3	46.2	0		6.8	84.9	8.2	0		
PHF	.875	.881	.523	.000	.727	.806	.714	.830	.000	.751	.815	.721	.845	.000	.900	.824	.858	.799	.000	.891	.847

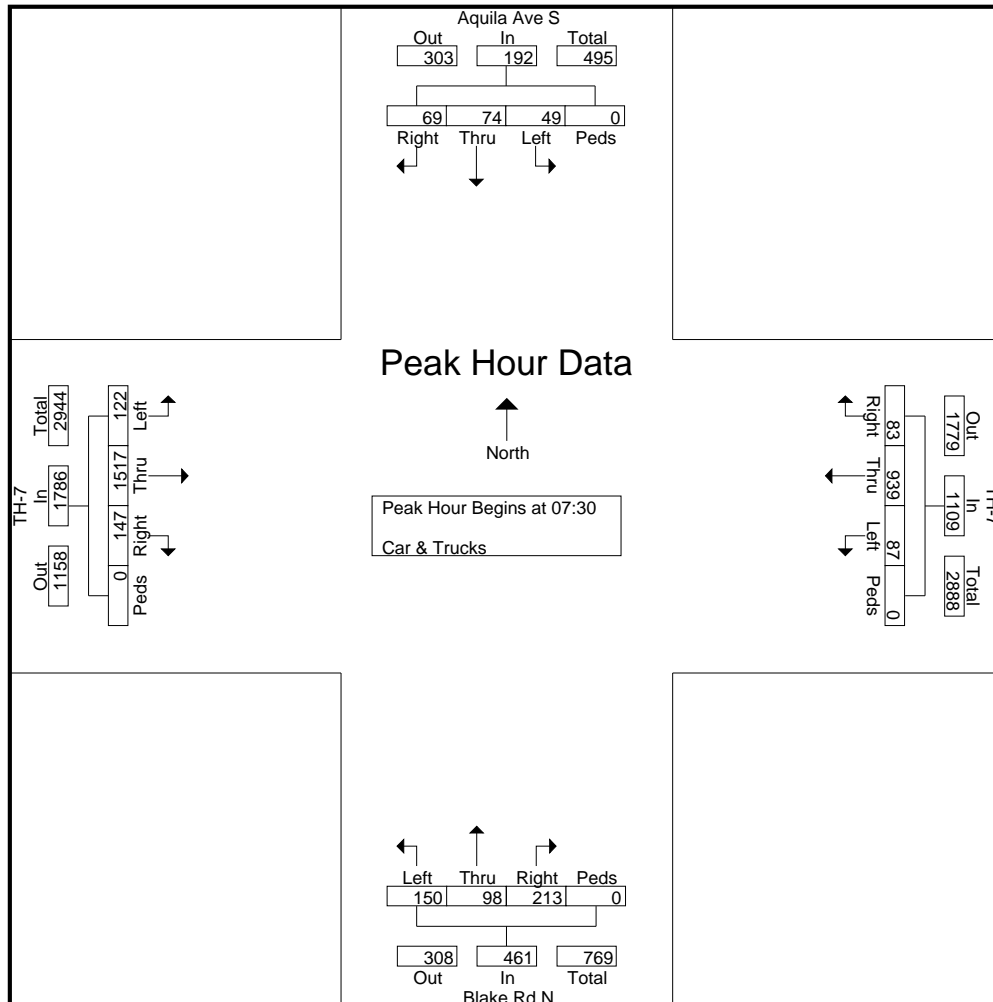



MINNESOTA DEPT OF TRANSPORTATION

TRAFFIC DATA COLLECTION - METRO

TH-7 at Blake Rd N / Aquila Ave S
 ref.pt.: 192.257
 collected by: ALLIANT CONSULT.
 TURN MOVEMENT COUNT

File Name : TH-7 at Blake Rd - Aquila Ave 2007
 Site Code : 00000160
 Start Date : 12/11/2007
 Page No : 4

Start Time	Aquila Ave S Southbound					TH-7 Westbound					Blake Rd N Northbound					TH-7 Eastbound					Int. Total
	Left	Thru	Right	Peds	App. Total	Left	Thru	Right	Peds	App. Total	Left	Thru	Right	Peds	App. Total	Left	Thru	Right	Peds	App. Total	
Peak Hour Analysis From 14:30 to 17:45 - Peak 1 of 1																					
Peak Hour for Entire Intersection Begins at 16:45																					
16:45	42	60	92	0	194	79	271	41	0	391	47	124	80	0	251	118	369	48	0	535	1371
17:00	38	57	93	0	188	54	281	50	1	386	56	90	47	0	193	129	330	40	0	499	1266
17:15	38	66	100	0	204	71	264	22	0	357	53	92	61	0	206	128	397	40	0	565	1332
17:30	44	53	77	0	174	64	256	42	0	362	45	91	66	0	202	139	369	56	0	564	1302
Total Volume	162	236	362	0	760	268	1072	155	1	1496	201	397	254	0	852	514	1465	184	0	2163	5271
% App. Total	21.3	31.1	47.6	0		17.9	71.7	10.4	0.1		23.6	46.6	29.8	0		23.8	67.7	8.5	0		
PHF	.920	.894	.905	.000	.931	.848	.954	.775	.250	.957	.897	.800	.794	.000	.849	.924	.923	.821	.000	.957	.961

