



# MINNESOTA DEPT OF TRANSPORTATION

## TRAFFIC DATA COLLECTION - METRO

Aquila Ave at 37th St. (St Louis Park)  
 ref.pt.:  
 collected by: ALLIANT CONSULT.  
 TURN MOVEMENT COUNT

File Name : Aquila Ave at 37th St 2007  
 Site Code : 00000159  
 Start Date : 12/11/2007  
 Page No : 1

Groups Printed- Cars & Trucks

Start Time	Aquila Ave Southbound				37th St Westbound				Aquila Ave Northbound				37th St Eastbound				Int. Total
	Left	Thru	Right	Peds	Left	Thru	Right	Peds	Left	Thru	Right	Peds	Left	Thru	Right	Peds	
06:00	2	7	0	0	0	1	1	0	6	9	0	0	0	0	3	0	29
06:15	1	16	1	0	2	0	1	0	3	15	0	0	0	0	7	0	46
06:30	2	12	1	0	2	0	2	0	13	13	0	0	0	0	14	0	59
06:45	2	20	2	0	5	1	1	0	11	16	0	0	1	0	6	0	65
Total	7	55	4	0	9	2	5	0	33	53	0	0	1	0	30	0	199
07:00	3	22	1	0	7	0	1	0	13	18	2	0	0	1	7	0	75
07:15	1	37	1	0	5	0	5	0	15	20	0	0	0	1	4	0	89
07:30	2	37	2	0	5	1	0	0	19	20	0	0	0	1	15	0	102
07:45	4	39	5	0	8	1	4	0	29	37	0	0	1	1	22	0	151
Total	10	135	9	0	25	2	10	0	76	95	2	0	1	4	48	0	417
08:00	3	28	4	0	13	2	9	0	37	26	0	0	4	1	20	0	147
08:15	2	28	5	0	6	2	0	0	53	29	1	0	2	0	17	0	145
08:30	1	27	3	0	9	1	11	0	47	23	2	0	3	3	36	0	166
08:45	8	35	4	0	7	6	3	0	45	28	1	0	3	3	32	0	175
Total	14	118	16	0	35	11	23	0	182	106	4	0	12	7	105	0	633
09:00	4	21	7	0	7	2	2	0	57	22	0	0	7	5	34	0	168
09:15	8	21	5	0	10	11	2	0	83	32	2	0	12	2	47	0	235
*** BREAK ***																	
Total	12	42	12	0	17	13	4	0	140	54	2	0	19	7	81	0	403
*** BREAK ***																	
10:30	9	25	6	0	22	2	10	0	71	26	3	0	20	12	58	0	264
10:45	5	26	7	0	30	7	11	0	86	38	3	0	10	8	66	0	297
Total	14	51	13	0	52	9	21	0	157	64	6	0	30	20	124	0	561
11:00	11	24	12	0	33	7	11	0	114	32	0	0	12	15	66	0	337
11:15	13	39	13	0	36	3	5	0	84	33	6	0	11	11	91	0	345
11:30	9	41	11	0	45	21	4	0	114	41	2	0	8	11	82	0	389
11:45	14	53	6	0	46	13	4	0	129	48	11	0	9	11	85	0	429
Total	47	157	42	0	160	44	24	0	441	154	19	0	40	48	324	0	1500
12:00	12	41	17	0	43	17	10	0	136	47	2	0	10	10	99	0	444
12:15	7	57	15	0	48	17	11	0	125	73	1	0	22	11	127	0	514
12:30	9	58	16	0	60	15	15	0	131	49	3	0	16	13	132	0	517
12:45	7	59	8	0	53	11	13	0	115	53	3	0	10	14	126	0	472
Total	35	215	56	0	204	60	49	0	507	222	9	0	58	48	484	0	1947
13:00	6	36	16	0	65	12	13	0	113	46	5	0	19	10	129	0	470
13:15	14	50	9	0	72	14	17	1	117	47	3	0	15	15	114	0	488
*** BREAK ***																	
Total	20	86	25	0	137	26	30	1	230	93	8	0	34	25	243	0	958
*** BREAK ***																	
14:30	4	48	13	0	40	15	13	0	87	46	2	0	16	13	89	0	386
14:45	5	51	9	0	69	17	15	0	117	69	3	0	12	10	98	0	475
Total	9	99	22	0	109	32	28	0	204	115	5	0	28	23	187	0	861
15:00	4	38	10	0	65	10	8	0	102	48	5	0	16	15	119	0	440
15:15	7	43	9	0	46	18	9	0	99	45	7	0	15	11	120	0	429
15:30	5	51	14	0	52	13	12	0	91	61	3	0	14	8	104	0	428
15:45	7	47	17	0	38	8	5	0	103	51	2	0	16	7	99	0	400
Total	23	179	50	0	201	49	34	0	395	205	17	0	61	41	442	0	1697



# MINNESOTA DEPT OF TRANSPORTATION

## TRAFFIC DATA COLLECTION - METRO

Aquila Ave at 37th St. (St Louis Park)

ref.pt.:

collected by: ALLIANT CONSULT.

TURN MOVEMENT COUNT

File Name : Aquila Ave at 37th St 2007

Site Code : 00000159

Start Date : 12/11/2007

Page No : 2

Groups Printed- Cars & Trucks

Start Time	Aquila Ave Southbound				37th St Westbound				Aquila Ave Northbound				37th St Eastbound				Int. Total
	Left	Thru	Right	Peds	Left	Thru	Right	Peds	Left	Thru	Right	Peds	Left	Thru	Right	Peds	
16:00	8	34	13	0	49	20	5	0	106	63	3	0	21	11	100	0	433
16:15	14	55	14	0	43	12	8	0	105	66	2	0	14	10	93	0	436
16:30	3	42	18	0	48	10	18	0	99	68	4	0	26	9	106	0	451
16:45	5	69	24	0	49	23	7	0	143	78	2	0	28	12	96	0	536
Total	30	200	69	0	189	65	38	0	453	275	11	0	89	42	395	0	1856
17:00	10	50	25	0	46	11	10	0	105	86	1	0	18	6	101	0	469
17:15	12	45	14	0	49	13	11	0	113	69	3	0	14	13	104	0	460
17:30	7	42	20	0	49	11	11	0	116	79	3	0	19	10	93	0	460
17:45	4	41	24	0	69	9	8	0	106	69	3	0	22	12	103	0	470
Total	33	178	83	0	213	44	40	0	440	303	10	0	73	41	401	0	1859
Grand Total	254	1515	401	0	1351	357	306	1	3258	1739	93	0	446	306	2864	0	12891
Apprch %	11.7	69.8	18.5	0	67	17.7	15.2	0	64	34.2	1.8	0	12.3	8.5	79.2	0	
Total %	2	11.8	3.1	0	10.5	2.8	2.4	0	25.3	13.5	0.7	0	3.5	2.4	22.2	0	



# MINNESOTA DEPT OF TRANSPORTATION

## TRAFFIC DATA COLLECTION - METRO

Aquila Ave at 37th St. (St Louis Park)  
 ref.pt.:  
 collected by: ALLIANT CONSULT.  
 TURN MOVEMENT COUNT

File Name : Aquila Ave at 37th St 2007  
 Site Code : 00000159  
 Start Date : 12/11/2007  
 Page No : 3

Start Time	Aquila Ave Southbound					37th St Westbound					Aquila Ave Northbound					37th St Eastbound					Int. Total
	Left	Thru	Right	Peds	App. Total	Left	Thru	Right	Peds	App. Total	Left	Thru	Right	Peds	App. Total	Left	Thru	Right	Peds	App. Total	
Peak Hour Analysis From 06:00 to 09:15 - Peak 1 of 1																					
Peak Hour for Entire Intersection Begins at 08:30																					
08:30	1	27	3	0	31	9	1	11	0	21	47	23	2	0	72	3	3	36	0	42	166
08:45	8	35	4	0	47	7	6	3	0	16	45	28	1	0	74	3	3	32	0	38	175
09:00	4	21	7	0	32	7	2	2	0	11	57	22	0	0	79	7	5	34	0	46	168
09:15	8	21	5	0	34	10	11	2	0	23	83	32	2	0	117	12	2	47	0	61	235
Total Volume	21	104	19	0	144	33	20	18	0	71	232	105	5	0	342	25	13	149	0	187	744
% App. Total																					
PHF	.656	.743	.679	.000	.766	.825	.455	.409	.000	.772	.699	.820	.625	.000	.731	.521	.650	.793	.000	.766	.791

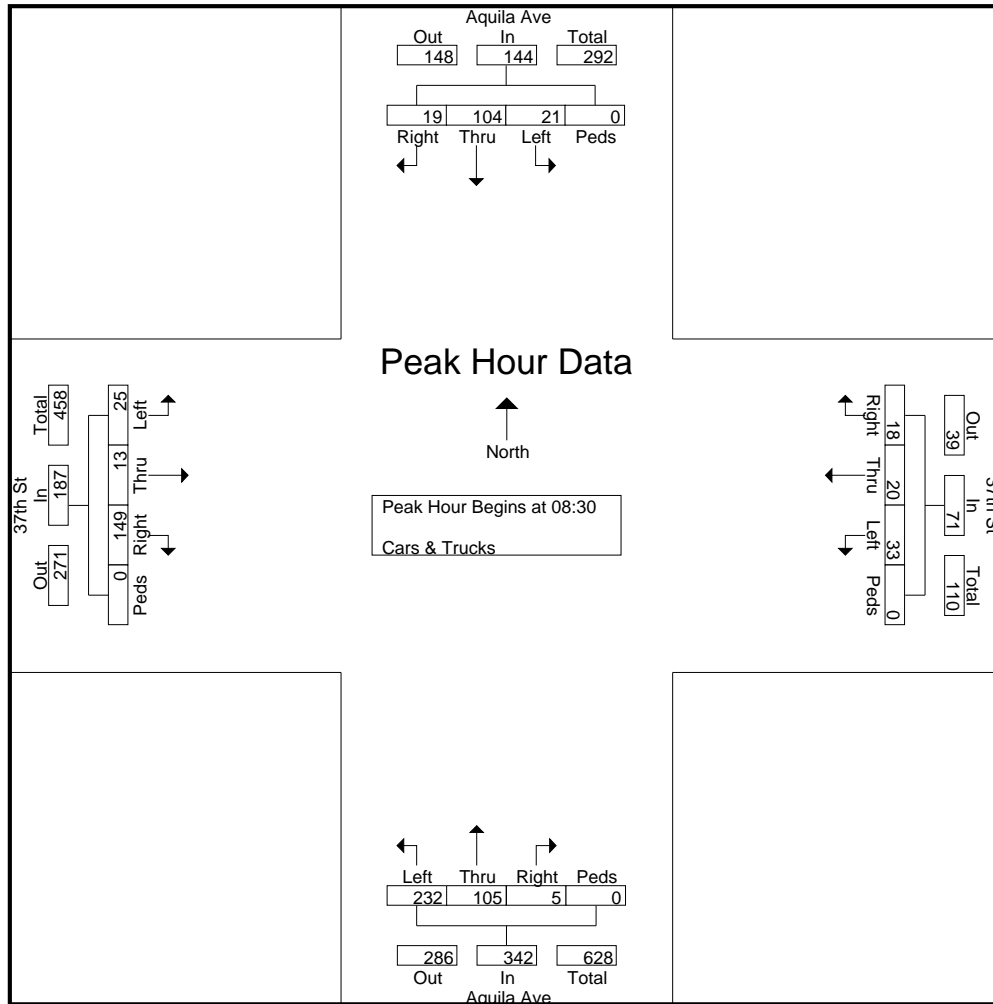



# MINNESOTA DEPT OF TRANSPORTATION

TRAFFIC DATA COLLECTION - METRO

Aquila Ave at 37th St. (St Louis Park)  
 ref.pt.:  
 collected by: ALLIANT CONSULT.  
 TURN MOVEMENT COUNT

File Name : Aquila Ave at 37th St 2007  
 Site Code : 00000159  
 Start Date : 12/11/2007  
 Page No : 4

Start Time	Aquila Ave Southbound					37th St Westbound					Aquila Ave Northbound					37th St Eastbound					Int. Total
	Left	Thru	Right	Peds	App. Total	Left	Thru	Right	Peds	App. Total	Left	Thru	Right	Peds	App. Total	Left	Thru	Right	Peds	App. Total	
Peak Hour Analysis From 14:30 to 17:45 - Peak 1 of 1																					
Peak Hour for Entire Intersection Begins at 16:45																					
16:45	5	69	24	0	98	49	23	7	0	79	143	78	2	0	223	28	12	96	0	136	536
17:00	10	50	25	0	85	46	11	10	0	67	105	86	1	0	192	18	6	101	0	125	469
17:15	12	45	14	0	71	49	13	11	0	73	113	69	3	0	185	14	13	104	0	131	460
17:30	7	42	20	0	69	49	11	11	0	71	116	79	3	0	198	19	10	93	0	122	460
Total Volume	34	206	83	0	323	193	58	39	0	290	477	312	9	0	798	79	41	394	0	514	1925
% App. Total																					
PHF	.708	.746	.830	.000	.824	.985	.630	.886	.000	.918	.834	.907	.750	.000	.895	.705	.788	.947	.000	.945	.898

