



# MINNESOTA DEPT OF TRANSPORTATION

## TRAFFIC DATA COLLECTION - METRO

TH-7 at Williston Rd.  
 ref.pt.: 188.039  
 Counter: Ken Levin - ALLIANT CONSULT  
 TURN MOVEMENT COUNT

File Name : TH-7 at Williston Rd 2007  
 Site Code : 00000144  
 Start Date : 11/27/2007  
 Page No : 1

### Groups Printed- Cars & Trucks

Start Time	Williston Rd Southbound				TH-7 Westbound				Williston Rd Northbound				TH-7 Eastbound				Int. Total
	Left	Thru	Right	Peds	Left	Thru	Right	Peds	Left	Thru	Right	Peds	Left	Thru	Right	Peds	
06:00	15	1	1	0	6	89	0	0	3	8	6	0	6	229	1	0	365
06:15	21	6	1	0	9	108	1	0	0	0	11	0	9	340	1	0	507
06:30	31	2	0	0	18	148	5	0	3	3	22	0	19	436	1	0	688
06:45	37	5	5	0	24	181	13	0	2	16	29	0	33	543	0	0	888
<b>Total</b>	<b>104</b>	<b>14</b>	<b>7</b>	<b>0</b>	<b>57</b>	<b>526</b>	<b>19</b>	<b>0</b>	<b>8</b>	<b>27</b>	<b>68</b>	<b>0</b>	<b>67</b>	<b>1548</b>	<b>3</b>	<b>0</b>	<b>2448</b>
07:00	41	5	5	0	25	186	9	0	3	18	24	0	17	594	2	0	929
07:15	50	16	8	0	19	230	10	0	4	16	48	0	20	609	2	0	1032
07:30	62	27	14	0	25	236	12	0	5	21	51	0	22	632	0	0	1107
07:45	57	37	18	0	38	237	25	0	11	24	53	0	26	574	1	0	1101
<b>Total</b>	<b>210</b>	<b>85</b>	<b>45</b>	<b>0</b>	<b>107</b>	<b>889</b>	<b>56</b>	<b>0</b>	<b>23</b>	<b>79</b>	<b>176</b>	<b>0</b>	<b>85</b>	<b>2409</b>	<b>5</b>	<b>0</b>	<b>4169</b>
08:00	66	15	11	0	25	180	18	0	7	17	35	0	31	503	2	0	910
08:15	48	22	13	0	26	195	27	0	2	9	32	0	15	605	10	0	1004
08:30	46	25	10	0	34	179	10	0	8	8	26	0	12	490	3	0	851
08:45	46	12	14	0	25	194	6	0	4	13	21	0	21	430	8	0	794
<b>Total</b>	<b>206</b>	<b>74</b>	<b>48</b>	<b>0</b>	<b>110</b>	<b>748</b>	<b>61</b>	<b>0</b>	<b>21</b>	<b>47</b>	<b>114</b>	<b>0</b>	<b>79</b>	<b>2028</b>	<b>23</b>	<b>0</b>	<b>3559</b>
09:00	36	11	10	0	32	180	6	0	9	14	14	0	15	355	4	0	686
09:15	31	6	7	0	25	172	6	0	9	17	16	0	22	342	4	0	657
*** BREAK ***																	
<b>Total</b>	<b>67</b>	<b>17</b>	<b>17</b>	<b>0</b>	<b>57</b>	<b>352</b>	<b>12</b>	<b>0</b>	<b>18</b>	<b>31</b>	<b>30</b>	<b>0</b>	<b>37</b>	<b>697</b>	<b>8</b>	<b>0</b>	<b>1343</b>
*** BREAK ***																	
10:30	24	14	16	0	43	160	11	0	6	7	9	0	12	253	9	0	564
10:45	39	19	13	0	30	172	10	0	15	12	10	0	14	239	9	0	582
<b>Total</b>	<b>63</b>	<b>33</b>	<b>29</b>	<b>0</b>	<b>73</b>	<b>332</b>	<b>21</b>	<b>0</b>	<b>21</b>	<b>19</b>	<b>19</b>	<b>0</b>	<b>26</b>	<b>492</b>	<b>18</b>	<b>0</b>	<b>1146</b>
11:00	38	9	17	0	34	181	14	0	14	12	8	0	12	244	8	0	591
11:15	27	14	24	0	46	203	12	0	14	5	11	0	23	257	15	0	651
11:30	36	20	25	0	58	207	16	0	18	17	11	0	23	255	18	0	704
11:45	31	18	26	0	39	214	13	0	29	14	11	0	19	251	18	0	683
<b>Total</b>	<b>132</b>	<b>61</b>	<b>92</b>	<b>0</b>	<b>177</b>	<b>805</b>	<b>55</b>	<b>0</b>	<b>75</b>	<b>48</b>	<b>41</b>	<b>0</b>	<b>77</b>	<b>1007</b>	<b>59</b>	<b>0</b>	<b>2629</b>
12:00	38	23	14	0	54	189	16	0	13	10	5	0	28	239	10	0	639
12:15	35	14	18	0	32	210	27	0	24	17	7	0	29	222	15	0	650
12:30	38	13	17	0	43	223	14	0	21	19	9	0	29	269	12	0	707
12:45	35	21	14	0	48	206	19	0	22	12	11	0	31	250	9	0	678
<b>Total</b>	<b>146</b>	<b>71</b>	<b>63</b>	<b>0</b>	<b>177</b>	<b>828</b>	<b>76</b>	<b>0</b>	<b>80</b>	<b>58</b>	<b>32</b>	<b>0</b>	<b>117</b>	<b>980</b>	<b>46</b>	<b>0</b>	<b>2674</b>
13:00	35	20	15	0	46	226	28	0	21	19	3	0	26	241	13	0	693
13:15	26	14	11	0	34	215	15	0	21	23	7	0	14	265	6	0	651
*** BREAK ***																	
<b>Total</b>	<b>61</b>	<b>34</b>	<b>26</b>	<b>0</b>	<b>80</b>	<b>441</b>	<b>43</b>	<b>0</b>	<b>42</b>	<b>42</b>	<b>10</b>	<b>0</b>	<b>40</b>	<b>506</b>	<b>19</b>	<b>0</b>	<b>1344</b>
*** BREAK ***																	
14:30	35	17	16	0	48	307	17	0	19	15	3	0	15	242	9	0	743
14:45	25	15	25	0	49	357	20	0	24	13	8	0	19	264	16	0	835
<b>Total</b>	<b>60</b>	<b>32</b>	<b>41</b>	<b>0</b>	<b>97</b>	<b>664</b>	<b>37</b>	<b>0</b>	<b>43</b>	<b>28</b>	<b>11</b>	<b>0</b>	<b>34</b>	<b>506</b>	<b>25</b>	<b>0</b>	<b>1578</b>
15:00	26	14	17	0	65	344	15	0	24	14	9	0	31	299	8	0	866
15:15	41	16	25	0	32	403	39	1	14	23	14	0	17	260	13	0	898
15:30	36	10	22	0	54	452	27	0	21	11	3	0	19	317	11	0	983
15:45	40	17	20	0	69	459	38	0	17	19	9	1	22	315	7	0	1033
<b>Total</b>	<b>143</b>	<b>57</b>	<b>84</b>	<b>0</b>	<b>220</b>	<b>1658</b>	<b>119</b>	<b>1</b>	<b>76</b>	<b>67</b>	<b>35</b>	<b>1</b>	<b>89</b>	<b>1191</b>	<b>39</b>	<b>0</b>	<b>3780</b>



# MINNESOTA DEPT OF TRANSPORTATION

## TRAFFIC DATA COLLECTION - METRO

TH-7 at Williston Rd.  
 ref.pt.: 188.039  
 Counter: Ken Levin - ALLIANT CONSULT  
 TURN MOVEMENT COUNT

File Name : TH-7 at Williston Rd 2007  
 Site Code : 00000144  
 Start Date : 11/27/2007  
 Page No : 2

### Groups Printed- Cars & Trucks

Start Time	Williston Rd Southbound				TH-7 Westbound				Williston Rd Northbound				TH-7 Eastbound				Int. Total
	Left	Thru	Right	Peds	Left	Thru	Right	Peds	Left	Thru	Right	Peds	Left	Thru	Right	Peds	
16:00	54	29	34	0	62	436	33	0	28	14	7	0	18	287	10	0	1012
16:15	46	23	26	0	55	494	27	0	18	25	3	0	25	295	10	0	1047
16:30	30	20	25	0	38	479	23	0	23	17	9	0	22	289	6	0	981
16:45	39	25	42	0	61	522	28	1	27	25	6	0	25	290	13	0	1104
Total	169	97	127	0	216	1931	111	1	96	81	25	0	90	1161	39	0	4144
17:00	53	19	33	0	47	484	19	0	24	40	8	0	23	273	8	0	1031
17:15	47	38	30	0	72	487	21	0	30	26	7	0	38	335	9	0	1140
17:30	34	21	39	1	60	541	23	0	23	33	9	0	24	266	4	0	1078
17:45	30	14	31	0	55	552	16	0	20	35	8	0	23	263	9	0	1056
Total	164	92	133	1	234	2064	79	0	97	134	32	0	108	1137	30	0	4305
Grand Total	1525	667	712	1	1605	11238	689	2	600	661	593	1	849	13662	314	0	33119
Apprch %	52.5	23	24.5	0	11.9	83	5.1	0	32.3	35.6	32	0.1	5.7	92.2	2.1	0	
Total %	4.6	2	2.1	0	4.8	33.9	2.1	0	1.8	2	1.8	0	2.6	41.3	0.9	0	



# MINNESOTA DEPT OF TRANSPORTATION

TRAFFIC DATA COLLECTION - METRO

TH-7 at Williston Rd.  
 ref.pt.: 188.039  
 Counter: Ken Levin - ALLIANT CONSULT  
 TURN MOVEMENT COUNT

File Name : TH-7 at Williston Rd 2007  
 Site Code : 00000144  
 Start Date : 11/27/2007  
 Page No : 3

Start Time	Williston Rd Southbound					TH-7 Westbound					Williston Rd Northbound					TH-7 Eastbound					Int. Total
	Left	Thru	Right	Peds	App. Total	Left	Thru	Right	Peds	App. Total	Left	Thru	Right	Peds	App. Total	Left	Thru	Right	Peds	App. Total	
Peak Hour Analysis From 06:00 to 09:15 - Peak 1 of 1																					
Peak Hour for Entire Intersection Begins at 07:00																					
07:00	41	5	5	0	51	25	186	9	0	220	3	18	24	0	45	17	594	2	0	613	929
07:15	50	16	8	0	74	19	230	10	0	259	4	16	48	0	68	20	609	2	0	631	1032
07:30	<b>62</b>	27	14	0	103	25	236	12	0	273	5	21	51	0	77	22	<b>632</b>	0	0	<b>654</b>	<b>1107</b>
07:45	57	<b>37</b>	<b>18</b>	0	<b>112</b>	<b>38</b>	<b>237</b>	<b>25</b>	0	<b>300</b>	<b>11</b>	<b>24</b>	<b>53</b>	0	<b>88</b>	<b>26</b>	574	1	0	601	1101
Total Volume	210	85	45	0	340	107	889	56	0	1052	23	79	176	0	278	85	2409	5	0	2499	4169
% App. Total	61.8	25	13.2	0		10.2	84.5	5.3	0		8.3	28.4	63.3	0		3.4	96.4	0.2	0		
PHF	.847	.574	.625	.000	.759	.704	.938	.560	.000	.877	.523	.823	.830	.000	.790	.817	.953	.625	.000	.955	.942

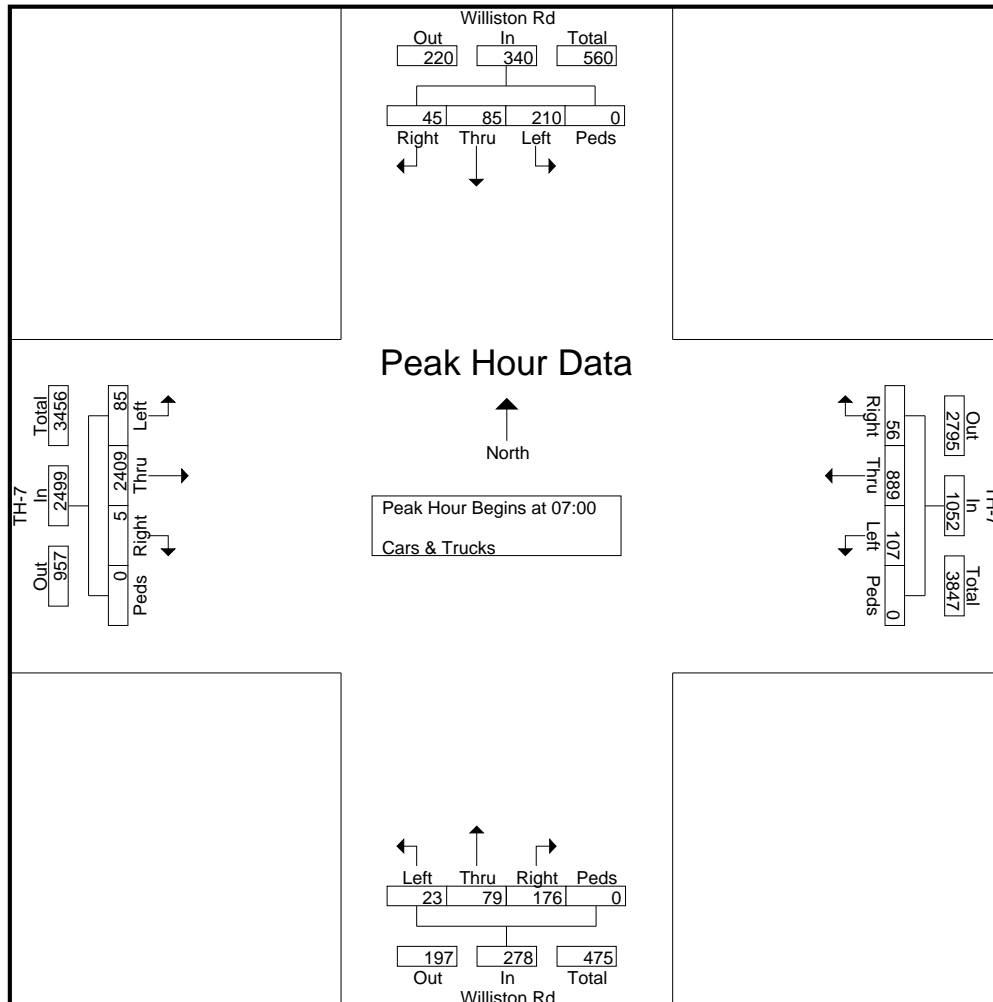



# MINNESOTA DEPT OF TRANSPORTATION

TRAFFIC DATA COLLECTION - METRO

TH-7 at Williston Rd.  
 ref.pt.: 188.039  
 Counter: Ken Levin - ALLIANT CONSULT  
 TURN MOVEMENT COUNT

File Name : TH-7 at Williston Rd 2007  
 Site Code : 00000144  
 Start Date : 11/27/2007  
 Page No : 4

Start Time	Williston Rd Southbound					TH-7 Westbound					Williston Rd Northbound					TH-7 Eastbound					Int. Total
	Left	Thru	Right	Peds	App. Total	Left	Thru	Right	Peds	App. Total	Left	Thru	Right	Peds	App. Total	Left	Thru	Right	Peds	App. Total	
Peak Hour Analysis From 14:30 to 17:45 - Peak 1 of 1																					
Peak Hour for Entire Intersection Begins at 16:45																					
16:45	39	25	42	0	106	61	522	28	1	612	27	25	6	0	58	25	290	13	0	328	1104
17:00	53	19	33	0	105	47	484	19	0	550	24	40	8	0	72	23	273	8	0	304	1031
17:15	47	38	30	0	115	72	487	21	0	580	30	26	7	0	63	38	335	9	0	382	1140
17:30	34	21	39	1	95	60	541	23	0	624	23	33	9	0	65	24	266	4	0	294	1078
Total Volume	173	103	144	1	421	240	2034	91	1	2366	104	124	30	0	258	110	1164	34	0	1308	4353
% App. Total	41.1	24.5	34.2	0.2		10.1	86	3.8	0		40.3	48.1	11.6	0		8.4	89	2.6	0		
PHF	.816	.678	.857	.250	.915	.833	.940	.813	.250	.948	.867	.775	.833	.000	.896	.724	.869	.654	.000	.856	.955

