

Alliant Engineering Inc Minneapolis, MN 55415

TH-7 at CSAH-101
Ref.Pt.: 186.196
Alliant Engineering Inc
TURN MOVEMENT COUNT

File Name : 8_TH 7 at CR 101_020211
Site Code : 00000008
Start Date : 2/2/2011
Page No : 1

Groups Printed- Unshifted - Bank 1

Start Time	CSAH-101 Southbound				TH-7 Westbound				CSAH-101 Northbound				TH-7 Eastbound				Int. Total
	Left	Thru	Right	Peds	Left	Thru	Right	Peds	Left	Thru	Right	Peds	Left	Thru	Right	Peds	
06:00	9	8	5	0	11	48	3	0	7	11	9	0	9	180	6	0	306
06:15	11	14	5	0	23	73	5	0	7	9	16	0	8	265	14	0	450
06:30	9	23	10	0	24	116	1	0	4	25	33	0	14	372	17	0	648
06:45	13	35	10	0	51	104	7	0	14	25	49	0	34	371	15	0	728
Total	42	80	30	0	109	341	16	0	32	70	107	0	65	1188	52	0	2132
07:00	11	37	13	0	44	80	9	0	16	50	69	0	30	388	41	0	788
07:15	18	38	16	0	53	121	10	0	19	70	100	0	26	540	49	1	1061
07:30	20	84	32	0	79	167	9	0	15	70	94	0	52	553	45	0	1220
07:45	28	110	28	0	72	162	5	0	30	137	86	0	51	513	57	1	1280
Total	77	269	89	0	248	530	33	0	80	327	349	0	159	1994	192	2	4349
08:00	25	57	15	0	34	105	14	0	26	113	57	0	50	453	59	2	1010
08:15	13	43	17	0	47	122	6	0	25	61	23	0	40	399	31	0	827
08:30	37	75	27	0	47	125	14	0	36	96	39	0	59	264	32	0	851
08:45	24	38	29	0	49	163	15	0	24	63	44	0	67	308	24	2	850
Total	99	213	88	0	177	515	49	0	111	333	163	0	216	1424	146	4	3538
09:00	24	70	44	0	36	145	20	0	41	66	26	1	39	235	27	0	774
09:15	37	52	23	0	17	130	15	0	38	46	30	0	40	238	20	3	689
*** BREAK ***																	
Total	61	122	67	0	53	275	35	0	79	112	56	1	79	473	47	3	1463
*** BREAK ***																	
10:30	23	36	33	0	27	131	19	0	17	46	22	0	21	137	10	0	522
10:45	45	78	28	0	19	118	19	0	17	61	34	0	35	172	28	0	654
Total	68	114	61	0	46	249	38	0	34	107	56	0	56	309	38	0	1176
11:00	31	40	28	0	35	124	18	0	26	61	25	0	58	133	29	0	608
11:15	54	94	30	0	28	150	6	0	41	48	25	0	49	197	19	0	741
11:30	41	62	36	0	33	120	31	0	38	53	36	0	58	164	23	0	695
11:45	62	83	39	0	43	152	22	0	40	78	38	0	40	172	24	0	793
Total	188	279	133	0	139	546	77	0	145	240	124	0	205	666	95	0	2837
12:00	45	65	28	0	34	122	24	0	53	60	35	0	47	148	29	0	690
12:15	50	81	39	0	38	120	15	0	32	73	44	0	39	173	22	0	726
12:30	34	75	38	0	32	155	19	0	49	64	27	0	41	165	27	0	726
12:45	38	78	38	0	36	141	19	0	40	76	29	0	36	209	31	0	771
Total	167	299	143	0	140	538	77	0	174	273	135	0	163	695	109	0	2913
13:00	57	77	39	0	31	151	25	0	37	80	42	0	40	164	20	0	763
13:15	57	82	45	0	48	167	14	0	26	66	31	1	24	235	29	0	825
*** BREAK ***																	
Total	114	159	84	0	79	318	39	0	63	146	73	1	64	399	49	0	1588
*** BREAK ***																	
14:30	35	92	61	0	49	210	16	0	37	50	30	0	37	148	26	0	791
14:45	39	77	44	0	55	209	18	0	57	129	74	1	61	181	24	0	969
Total	74	169	105	0	104	419	34	0	94	179	104	1	98	329	50	0	1760
15:00	31	85	37	0	53	209	31	0	38	103	51	0	38	189	36	0	901
15:15	34	88	56	0	46	250	18	0	46	89	51	1	40	175	32	1	927
15:30	23	75	51	0	58	238	19	0	45	133	59	0	20	200	39	0	960
15:45	28	61	41	0	39	235	26	0	46	117	33	0	43	190	22	0	881
Total	116	309	185	0	196	932	94	0	175	442	194	1	141	754	129	1	3669

Alliant Engineering Inc Minneapolis, MN 55415

TH-7 at CSAH-101
 Ref.Pt.: 186.196
 Alliant Engineering Inc
 TURN MOVEMENT COUNT

File Name : 8_TH 7 at CR 101_020211
 Site Code : 00000008
 Start Date : 2/2/2011
 Page No : 2

Groups Printed- Unshifted - Bank 1

Start Time	CSAH-101 Southbound				TH-7 Westbound				CSAH-101 Northbound				TH-7 Eastbound				Int. Total
	Left	Thru	Right	Peds	Left	Thru	Right	Peds	Left	Thru	Right	Peds	Left	Thru	Right	Peds	
16:00	28	79	34	0	66	242	9	0	59	96	58	0	45	183	24	0	923
16:15	29	108	59	0	50	294	14	0	73	103	61	0	29	198	35	0	1053
16:30	30	86	61	0	58	359	17	0	74	119	53	0	22	198	24	0	1101
16:45	28	86	35	0	47	321	35	1	57	94	58	0	38	173	22	0	995
Total	115	359	189	0	221	1216	75	1	263	412	230	0	134	752	105	0	4072
17:00	14	60	59	0	62	335	31	0	62	101	81	0	22	142	18	0	987
17:15	37	101	75	0	81	327	39	0	93	101	44	0	62	235	31	0	1226
17:30	23	71	57	0	85	391	38	0	76	131	92	0	30	176	31	0	1201
17:45	37	139	76	0	69	433	43	0	77	132	69	0	41	180	26	0	1322
Total	111	371	267	0	297	1486	151	0	308	465	286	0	155	733	106	0	4736
Grand Total	1232	2743	1441	0	1809	7365	718	1	1558	3106	1877	4	1535	9716	1118	10	34233
Apprch %	22.7	50.6	26.6	0	18.3	74.4	7.3	0	23.8	47.5	28.7	0.1	12.4	78.5	9	0.1	
Total %	3.6	8	4.2	0	5.3	21.5	2.1	0	4.6	9.1	5.5	0	4.5	28.4	3.3	0	
Unshifted	1210	2685	1400	0	1765	7213	702	1	1515	3040	1844	4	1506	9540	1082	9	33516
% Unshifted	98.2	97.9	97.2	0	97.6	97.9	97.8	100	97.2	97.9	98.2	100	98.1	98.2	96.8	90	97.9
Bank 1	22	58	41	0	44	152	16	0	43	66	33	0	29	176	36	1	717
% Bank 1	1.8	2.1	2.8	0	2.4	2.1	2.2	0	2.8	2.1	1.8	0	1.9	1.8	3.2	10	2.1

Alliant Engineering Inc Minneapolis, MN 55415

TH-7 at CSAH-101
Ref.Pt.: 186.196
Alliant Engineering Inc
TURN MOVEMENT COUNT

File Name : 8_TH 7 at CR 101_020211
Site Code : 00000008
Start Date : 2/2/2011
Page No : 3

Start Time	CSAH-101 Southbound					TH-7 Westbound					CSAH-101 Northbound					TH-7 Eastbound					Int. Total
	Left	Thru	Right	Peds	App. Total	Left	Thru	Right	Peds	App. Total	Left	Thru	Right	Peds	App. Total	Left	Thru	Right	Peds	App. Total	
Peak Hour Analysis From 06:00 to 09:15 - Peak 1 of 1																					
Peak Hour for Entire Intersection Begins at 07:15																					
07:15	18	38	16	0	72	53	121	10	0	184	19	70	100	0	189	26	540	49	1	616	1061
07:30	20	84	32	0	136	79	167	9	0	255	15	70	94	0	179	52	553	45	0	650	1220
07:45	28	110	28	0	166	72	162	5	0	239	30	137	86	0	253	51	513	57	1	622	1280
08:00	25	57	15	0	97	34	105	14	0	153	26	113	57	0	196	50	453	59	2	564	1010
Total Volume	91	289	91	0	471	238	555	38	0	831	90	390	337	0	817	179	2059	210	4	2452	4571
% App. Total	19.3	61.4	19.3	0		28.6	66.8	4.6	0		11	47.7	41.2	0		7.3	84	8.6	0.2		
PHF	.813	.657	.711	.000	.709	.753	.831	.679	.000	.815	.750	.712	.843	.000	.807	.861	.931	.890	.500	.943	.893

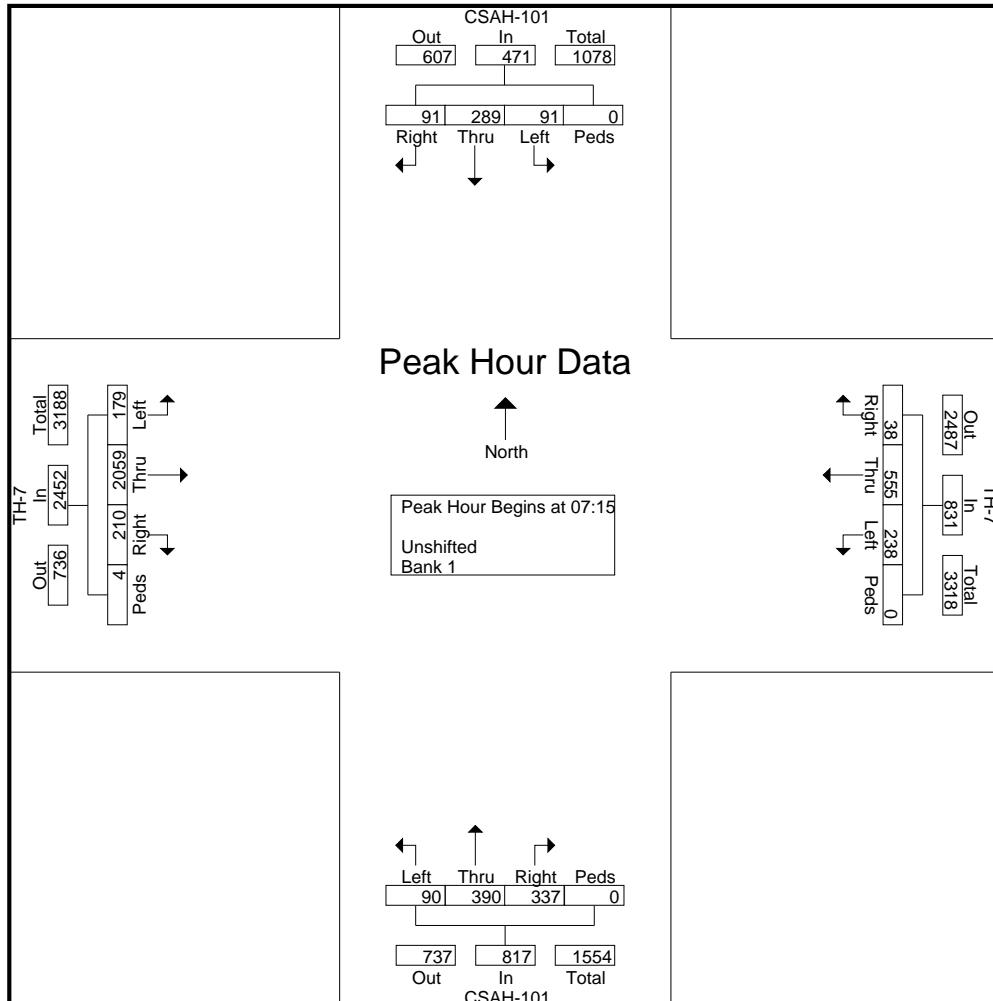

Alliant Engineering Inc Minneapolis, MN 55415

TH-7 at CSAH-101
 Ref.Pt.: 186.196
 Alliant Engineering Inc
 TURN MOVEMENT COUNT

File Name : 8_TH 7 at CR 101_020211
 Site Code : 00000008
 Start Date : 2/2/2011
 Page No : 4

Start Time	CSAH-101 Southbound					TH-7 Westbound					CSAH-101 Northbound					TH-7 Eastbound					Int. Total
	Left	Thru	Right	Peds	App. Total	Left	Thru	Right	Peds	App. Total	Left	Thru	Right	Peds	App. Total	Left	Thru	Right	Peds	App. Total	
Peak Hour Analysis From 14:30 to 17:45 - Peak 1 of 1																					
Peak Hour for Entire Intersection Begins at 17:00																					
17:00	14	60	59	0	133	62	335	31	0	428	62	101	81	0	244	22	142	18	0	182	987
17:15	37	101	75	0	213	81	327	39	0	447	93	101	44	0	238	62	235	31	0	328	1226
17:30	23	71	57	0	151	85	391	38	0	514	76	131	92	0	299	30	176	31	0	237	1201
17:45	37	139	76	0	252	69	433	43	0	545	77	132	69	0	278	41	180	26	0	247	1322
Total Volume	111	371	267	0	749	297	1486	151	0	1934	308	465	286	0	1059	155	733	106	0	994	4736
% App. Total	14.8	49.5	35.6	0		15.4	76.8	7.8	0		29.1	43.9	27	0		15.6	73.7	10.7	0		
PHF	.750	.667	.878	.000	.743	.874	.858	.878	.000	.887	.828	.881	.777	.000	.885	.625	.780	.855	.000	.758	.896

