



MINNESOTA DEPT OF TRANSPORTATION

TRAFFIC DATA COLLECTION - METRO

CSAH-101 at Hutchins Drive
ref.pt.:

Counter: Ken Levin - ALLIANT CONSULT
Turn Movement Count

File Name : CSAH-101 at Hutchins Drive 2007

Site Code : 00000154

Start Date : 12/5/2007

Page No : 1

Groups Printed- Cars & Trucks

Start Time	CSAH-101 Southbound				Hutchins Dr Westbound				CSAH-101 Northbound				Hutchins Dr Eastbound				Int. Total
	Left	Thru	Right	Peds	Left	Thru	Right	Peds	Left	Thru	Right	Peds	Left	Thru	Right	Peds	
06:15	5	37	1	0	0	0	1	0	1	55	2	0	5	0	1	0	108
06:30	4	52	10	0	1	0	3	0	0	76	10	0	8	0	1	0	165
06:45	3	82	10	0	2	1	2	0	4	76	6	1	6	0	0	0	193
Total	12	171	21	0	3	1	6	0	5	207	18	1	19	0	2	0	466
07:00	6	96	22	0	4	2	6	0	1	107	14	0	13	1	1	0	273
07:15	5	107	26	0	8	2	4	0	7	129	12	0	26	4	1	0	331
07:30	7	112	48	5	5	3	7	0	9	141	22	0	22	1	3	0	385
07:45	16	145	56	0	5	11	5	0	17	112	14	0	28	2	5	0	416
Total	34	460	152	5	22	18	22	0	34	489	62	0	89	8	10	0	1405
08:00	15	68	34	0	3	3	9	0	13	134	14	0	38	3	9	0	343
08:15	13	84	23	0	4	0	9	0	12	87	19	0	5	0	4	0	260
08:30	13	87	21	0	7	4	7	0	13	156	14	0	11	0	3	0	336
08:45	14	70	18	0	5	2	7	0	12	83	6	0	14	0	3	0	234
Total	55	309	96	0	19	9	32	0	50	460	53	0	68	3	19	0	1173
09:00	14	61	25	0	7	0	12	0	9	97	17	0	29	3	6	0	280
09:15	14	46	19	0	7	2	15	0	12	101	11	0	19	1	9	0	256
09:30	15	0	14	0	9	5	7	0	5	0	17	0	19	3	5	0	99
*** BREAK ***																	
Total	43	107	58	0	23	7	34	0	26	198	45	0	67	7	20	0	635
*** BREAK ***																	
10:30	10	61	12	0	8	3	7	0	11	60	5	0	19	2	7	0	205
10:45	13	105	14	0	4	2	12	0	7	67	6	0	27	3	8	0	268
Total	23	166	26	0	12	5	19	0	18	127	11	0	46	5	15	0	473
11:00	15	79	11	0	5	1	5	0	11	85	3	0	30	2	10	0	257
11:15	10	100	7	0	10	4	12	0	15	93	14	0	36	4	9	0	314
11:30	24	74	14	0	7	2	11	0	9	84	6	0	28	6	8	0	273
11:45	16	117	12	0	7	2	13	0	8	68	10	0	32	3	11	0	299
Total	65	370	44	0	29	9	41	0	43	330	33	0	126	15	38	0	1143
12:00	30	83	11	0	8	2	15	0	10	82	18	0	49	8	10	0	326
12:15	15	93	16	0	12	2	17	0	11	88	10	0	42	2	13	0	321
12:30	28	126	14	0	12	2	10	0	18	101	11	0	43	8	7	0	380
12:45	15	129	14	0	8	7	19	0	23	81	11	0	44	5	11	0	367
Total	88	431	55	0	40	13	61	0	62	352	50	0	178	23	41	0	1394
13:00	22	96	16	0	10	4	18	0	18	84	7	0	47	7	24	0	353
13:15	17	70	14	0	4	7	14	0	10	82	11	0	41	2	11	0	283
*** BREAK ***																	
Total	39	166	30	0	14	11	32	0	28	166	18	0	88	9	35	0	636
*** BREAK ***																	
14:30	17	135	24	0	6	2	26	0	12	108	6	0	29	5	8	0	378
14:45	24	127	23	0	7	3	23	0	7	135	5	0	56	2	9	0	421
Total	41	262	47	0	13	5	49	0	19	243	11	0	85	7	17	0	799
15:00	14	112	15	0	17	3	17	0	14	139	6	0	76	4	11	0	428
15:15	23	134	8	0	10	2	18	0	13	144	14	0	47	2	14	0	429
15:30	22	113	13	0	12	2	12	0	17	152	14	0	43	0	12	0	412
15:45	10	147	16	0	7	1	23	0	18	149	14	0	39	2	12	0	438
Total	69	506	52	0	46	8	70	0	62	584	48	0	205	8	49	0	1707



MINNESOTA DEPT OF TRANSPORTATION

TRAFFIC DATA COLLECTION - METRO

CSAH-101 at Hutchins Drive
 ref.pt.:
 Counter: Ken Levin - ALLIANT CONSULT
 Turn Movement Count

File Name : CSAH-101 at Hutchins Drive 2007
 Site Code : 00000154
 Start Date : 12/5/2007
 Page No : 2

Groups Printed- Cars & Trucks

Start Time	CSAH-101 Southbound				Hutchins Dr Westbound				CSAH-101 Northbound				Hutchins Dr Eastbound				Int. Total
	Left	Thru	Right	Peds	Left	Thru	Right	Peds	Left	Thru	Right	Peds	Left	Thru	Right	Peds	
16:00	14	137	14	0	4	4	20	0	19	150	7	1	35	3	8	0	416
16:15	16	160	5	0	16	4	20	0	13	171	16	0	38	3	14	0	476
16:30	14	155	16	0	9	3	13	0	18	163	13	0	50	0	10	0	464
16:45	14	144	18	0	16	5	20	0	20	201	10	0	45	2	12	0	507
Total	58	596	53	0	45	16	73	0	70	685	46	1	168	8	44	0	1863
17:00	11	150	12	0	15	1	31	0	16	197	12	0	67	5	22	0	539
17:15	9	154	8	0	12	2	25	0	9	200	10	0	52	2	11	0	494
17:30	8	165	12	0	14	3	21	0	8	221	9	0	48	1	20	0	530
17:45	8	167	8	0	15	0	9	0	10	209	4	0	31	2	13	0	476
Total	36	636	40	0	56	6	86	0	43	827	35	0	198	10	66	0	2039
Grand Total	563	4180	674	5	322	108	525	0	460	4668	430	2	1337	103	356	0	13733
Apprch %	10.4	77.1	12.4	0.1	33.7	11.3	55	0	8.3	84	7.7	0	74.4	5.7	19.8	0	
Total %	4.1	30.4	4.9	0	2.3	0.8	3.8	0	3.3	34	3.1	0	9.7	0.8	2.6	0	



MINNESOTA DEPT OF TRANSPORTATION

TRAFFIC DATA COLLECTION - METRO

CSAH-101 at Hutchins Drive
 ref.pt.:
 Counter: Ken Levin - ALLIANT CONSULT
 Turn Movement Count

File Name : CSAH-101 at Hutchins Drive 2007
 Site Code : 00000154
 Start Date : 12/5/2007
 Page No : 3

Start Time	CSAH-101 Southbound					Hutchins Dr Westbound					CSAH-101 Northbound					Hutchins Dr Eastbound					Int. Total
	Left	Thru	Right	Peds	App. Total	Left	Thru	Right	Peds	App. Total	Left	Thru	Right	Peds	App. Total	Left	Thru	Right	Peds	App. Total	
Peak Hour Analysis From 06:15 to 09:00 - Peak 1 of 1																					
Peak Hour for Entire Intersection Begins at 07:15																					
07:15	5	107	26	0	138	8	2	4	0	14	7	129	12	0	148	26	4	1	0	31	331
07:30	7	112	48	5	172	5	3	7	0	15	9	141	22	0	172	22	1	3	0	26	385
07:45	16	145	56	0	217	5	11	5	0	21	17	112	14	0	143	28	2	5	0	35	416
08:00	15	68	34	0	117	3	3	9	0	15	13	134	14	0	161	38	3	9	0	50	343
Total Volume	43	432	164	5	644	21	19	25	0	65	46	516	62	0	624	114	10	18	0	142	1475
% App. Total																					
PHF	.672	.745	.732	.250	.742	.656	.432	.694	.000	.774	.676	.915	.705	.000	.907	.750	.625	.500	.000	.710	.886

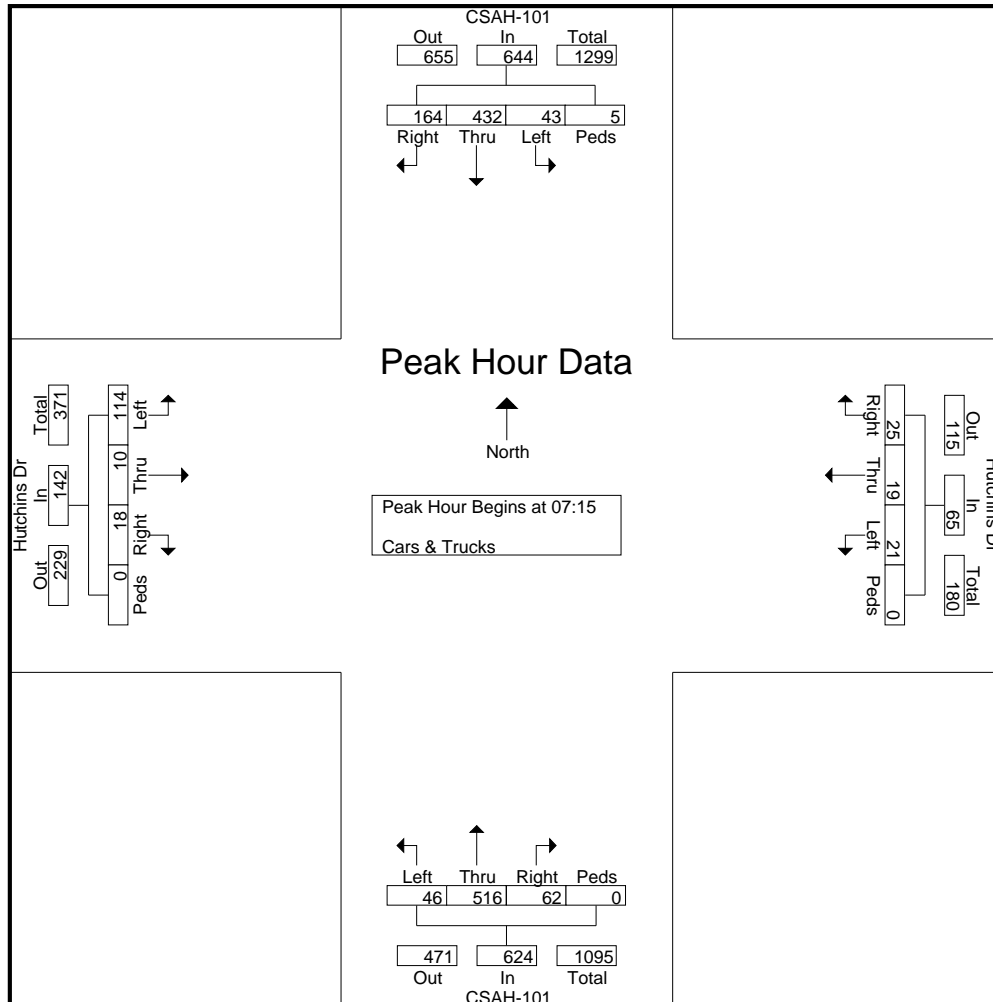



MINNESOTA DEPT OF TRANSPORTATION

TRAFFIC DATA COLLECTION - METRO

CSAH-101 at Hutchins Drive
 ref.pt.:
 Counter: Ken Levin - ALLIANT CONSULT
 Turn Movement Count

File Name : CSAH-101 at Hutchins Drive 2007
 Site Code : 00000154
 Start Date : 12/5/2007
 Page No : 4

Start Time	CSAH-101 Southbound					Hutchins Dr Westbound					CSAH-101 Northbound					Hutchins Dr Eastbound					Int. Total
	Left	Thru	Right	Peds	App. Total	Left	Thru	Right	Peds	App. Total	Left	Thru	Right	Peds	App. Total	Left	Thru	Right	Peds	App. Total	
Peak Hour Analysis From 15:00 to 17:45 - Peak 1 of 1																					
Peak Hour for Entire Intersection Begins at 16:45																					
16:45	14	144	18	0	176	16	5	20	0	41	20	201	10	0	231	45	2	12	0	59	507
17:00	11	150	12	0	173	15	1	31	0	47	16	197	12	0	225	67	5	22	0	94	539
17:15	9	154	8	0	171	12	2	25	0	39	9	200	10	0	219	52	2	11	0	65	494
17:30	8	165	12	0	185	14	3	21	0	38	8	221	9	0	238	48	1	20	0	69	530
Total Volume	42	613	50	0	705	57	11	97	0	165	53	819	41	0	913	212	10	65	0	287	2070
% App. Total																					
PHF	.750	.929	.694	.000	.953	.891	.550	.782	.000	.878	.663	.926	.854	.000	.959	.791	.500	.739	.000	.763	.960

