

# Alliant Engineering Inc Minneapolis, MN 55415

TH-65 at 85th Ave NE SPRING LAKE PARK  
 Ref.Pt.: 010.410  
 data by Alliant Engineering Inc  
 TURN MOVEMENT COUNT

File Name : TH-65 at 85th Ave NE 2009  
 Site Code : 00000009  
 Start Date : 1/8/2009  
 Page No : 1

### Groups Printed- Unshifted

Start Time	TH-65 Southbound				85th Ave NE Westbound				TH-65 Northbound				85th Ave NE Eastbound				Int. Total
	Left	Thru	Right	Peds	Left	Thru	Right	Peds	Left	Thru	Right	Peds	Left	Thru	Right	Peds	
06:00	2	348	0	0	25	9	3	0	0	53	8	0	0	1	2	0	451
06:15	10	425	0	0	51	0	7	0	1	58	19	0	0	3	1	0	575
06:30	11	519	0	0	68	0	3	0	0	56	20	0	0	0	6	0	683
06:45	12	536	0	0	79	4	5	0	0	94	26	0	0	0	4	0	760
Total	35	1828	0	0	223	13	18	0	1	261	73	0	0	4	13	0	2469
07:00	14	558	0	0	86	0	4	0	0	115	30	0	0	0	7	0	814
07:15	16	539	0	0	81	0	11	0	0	121	31	0	0	0	4	0	803
07:30	8	520	0	0	92	9	6	0	0	136	34	0	0	6	5	0	816
07:45	20	576	0	0	111	2	13	0	2	146	37	0	0	1	5	0	913
Total	58	2193	0	0	370	11	34	0	2	518	132	0	0	7	21	0	3346
08:00	27	412	0	0	69	1	10	0	1	126	54	0	0	2	1	0	703
08:15	14	357	0	0	65	2	6	0	4	111	41	0	0	0	3	0	603
08:30	23	339	1	0	51	2	8	0	2	139	26	0	1	0	3	0	595
08:45	17	315	1	0	53	1	4	0	4	120	24	0	0	0	2	0	541
Total	81	1423	2	0	238	6	28	0	11	496	145	0	1	2	9	0	2442
09:00	21	251	3	0	37	0	14	0	2	104	15	0	0	0	2	0	449
09:15	22	238	2	0	50	0	18	0	5	115	32	0	1	2	1	0	486
*** BREAK ***																	
Total	43	489	5	0	87	0	32	0	7	219	47	0	1	2	3	0	935
*** BREAK ***																	
10:30	16	203	2	1	31	3	6	0	10	155	24	0	3	3	0	1	458
10:45	21	195	5	0	52	1	17	1	5	162	21	0	2	0	5	0	487
Total	37	398	7	1	83	4	23	1	15	317	45	0	5	3	5	1	945
11:00	17	202	6	1	41	2	12	0	3	212	37	1	1	3	4	2	544
11:15	12	183	6	0	49	3	33	0	2	193	30	0	1	1	8	0	521
11:30	29	241	8	0	46	5	15	0	5	211	41	0	0	1	3	0	605
11:45	20	197	14	0	59	11	17	0	9	214	43	0	1	1	3	0	589
Total	78	823	34	1	195	21	77	0	19	830	151	1	3	6	18	2	2259
12:00	16	229	3	0	39	7	17	0	42	203	43	0	2	5	4	0	610
12:15	13	193	6	0	55	4	21	0	1	211	30	0	3	4	7	0	548
12:30	17	250	3	0	37	0	17	0	4	213	38	0	1	4	6	0	590
12:45	28	230	2	0	49	3	19	0	9	187	64	0	2	5	12	0	610
Total	74	902	14	0	180	14	74	0	56	814	175	0	8	18	29	0	2358
13:00	18	231	1	0	43	1	12	0	2	218	51	0	1	2	5	1	586
13:15	28	214	1	0	39	2	17	0	3	195	40	0	4	5	12	0	560
*** BREAK ***																	
Total	46	445	2	0	82	3	29	0	5	413	91	0	5	7	17	1	1146
*** BREAK ***																	
14:30	18	247	2	0	29	2	25	0	14	381	47	0	3	2	3	0	773
14:45	29	262	2	0	69	4	14	0	9	377	48	0	3	1	4	0	822
Total	47	509	4	0	98	6	39	0	23	758	95	0	6	3	7	0	1595
15:00	25	201	3	0	59	3	31	0	7	401	58	0	1	2	5	0	796
15:15	29	229	3	0	41	4	21	0	4	457	66	0	3	2	7	0	866
15:30	30	230	4	0	55	5	41	0	3	452	47	0	6	5	3	0	881
15:45	26	206	2	0	65	3	16	1	10	495	77	0	1	1	9	0	912
Total	110	866	12	0	220	15	109	1	24	1805	248	0	11	10	24	0	3455

# Alliant Engineering Inc Minneapolis, MN 55415

TH-65 at 85th Ave NE SPRING LAKE PARK  
 Ref.Pt.: 010.410  
 data by Alliant Engineering Inc  
 TURN MOVEMENT COUNT

File Name : TH-65 at 85th Ave NE 2009  
 Site Code : 00000009  
 Start Date : 1/8/2009  
 Page No : 2

**Groups Printed- Unshifted**

Start Time	TH-65 Southbound				85th Ave NE Westbound				TH-65 Northbound				85th Ave NE Eastbound				Int. Total
	Left	Thru	Right	Peds	Left	Thru	Right	Peds	Left	Thru	Right	Peds	Left	Thru	Right	Peds	
16:00	24	271	4	0	54	5	25	0	8	424	65	0	1	1	6	0	888
16:15	25	220	3	0	62	5	14	0	7	507	55	0	5	2	4	0	909
16:30	30	225	2	0	79	6	17	0	4	465	67	0	1	2	2	0	900
16:45	15	253	6	0	82	7	19	0	9	473	86	0	2	1	5	0	958
Total	94	969	15	0	277	23	75	0	28	1869	273	0	9	6	17	0	3655
17:00	23	214	3	0	71	6	23	0	4	535	63	0	5	0	6	0	953
17:15	25	244	19	0	55	2	16	0	7	498	78	0	1	1	2	0	948
17:30	19	244	8	0	71	5	20	0	9	442	54	0	5	1	3	0	881
17:45	24	226	3	0	55	4	18	0	6	407	45	0	0	0	1	0	789
Total	91	928	33	0	252	17	77	0	26	1882	240	0	11	2	12	0	3571
Grand Total	794	11773	128	2	2305	133	615	2	217	10182	1715	1	60	70	175	4	28176
Apprch %	6.3	92.7	1	0	75.5	4.4	20.1	0.1	1.8	84	14.2	0	19.4	22.7	56.6	1.3	
Total %	2.8	41.8	0.5	0	8.2	0.5	2.2	0	0.8	36.1	6.1	0	0.2	0.2	0.6	0	

# Alliant Engineering Inc Minneapolis, MN 55415

TH-65 at 85th Ave NE SPRING LAKE PARK  
 Ref.Pt.: 010.410  
 data by Alliant Engineering Inc  
 TURN MOVEMENT COUNT

File Name : TH-65 at 85th Ave NE 2009  
 Site Code : 00000009  
 Start Date : 1/8/2009  
 Page No : 3

Start Time	TH-65 Southbound					85th Ave NE Westbound					TH-65 Northbound					85th Ave NE Eastbound					Int. Total
	Left	Thru	Right	Peds	App. Total	Left	Thru	Right	Peds	App. Total	Left	Thru	Right	Peds	App. Total	Left	Thru	Right	Peds	App. Total	
Peak Hour Analysis From 06:00 to 08:45 - Peak 1 of 1																					
Peak Hour for Entire Intersection Begins at 07:00																					
07:00	14	558	0	0	572	86	0	4	0	90	0	115	30	0	145	0	0	7	0	7	814
07:15	16	539	0	0	555	81	0	11	0	92	0	121	31	0	152	0	0	4	0	4	803
07:30	8	520	0	0	528	92	9	6	0	107	0	136	34	0	170	0	6	5	0	11	816
07:45	20	576	0	0	596	111	2	13	0	126	2	146	37	0	185	0	1	5	0	6	913
Total Volume	58	2193	0	0	2251	370	11	34	0	415	2	518	132	0	652	0	7	21	0	28	3346
% App. Total	2.6	97.4	0	0		89.2	2.7	8.2	0		0.3	79.4	20.2	0		0	25	75	0		
PHF	.725	.952	.000	.000	.944	.833	.306	.654	.000	.823	.250	.887	.892	.000	.881	.000	.292	.750	.000	.636	.916

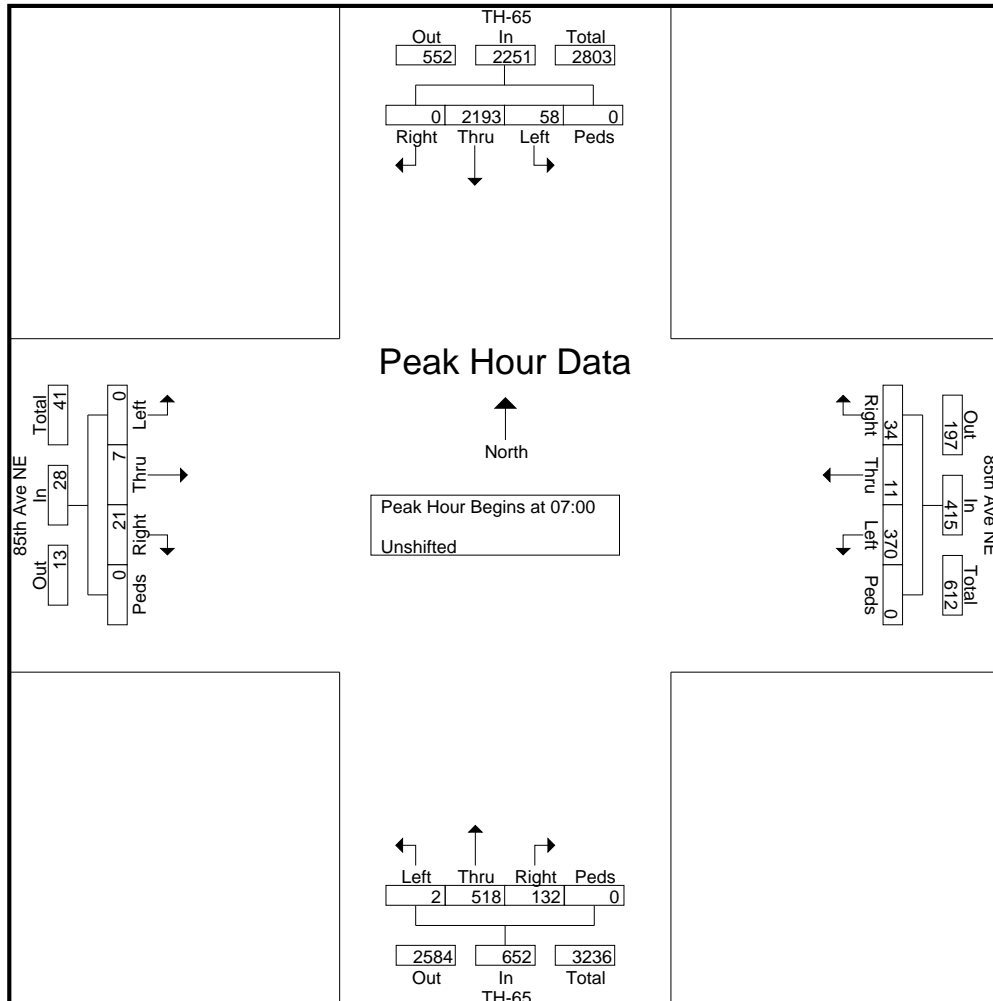

# Alliant Engineering Inc Minneapolis, MN 55415

TH-65 at 85th Ave NE SPRING LAKE PARK  
 Ref.Pt.: 010.410  
 data by Alliant Engineering Inc  
 TURN MOVEMENT COUNT

File Name : TH-65 at 85th Ave NE 2009  
 Site Code : 00000009  
 Start Date : 1/8/2009  
 Page No : 4

Start Time	TH-65 Southbound					85th Ave NE Westbound					TH-65 Northbound					85th Ave NE Eastbound					Int. Total
	Left	Thru	Right	Peds	App. Total	Left	Thru	Right	Peds	App. Total	Left	Thru	Right	Peds	App. Total	Left	Thru	Right	Peds	App. Total	
Peak Hour Analysis From 15:00 to 17:45 - Peak 1 of 1																					
Peak Hour for Entire Intersection Begins at 16:30																					
16:30	30	225	2	0	257	79	6	17	0	102	4	465	67	0	536	1	2	2	0	5	900
16:45	15	253	6	0	274	82	7	19	0	108	9	473	86	0	568	2	1	5	0	8	958
17:00	23	214	3	0	240	71	6	23	0	100	4	535	63	0	602	5	0	6	0	11	953
17:15	25	244	19	0	288	55	2	16	0	73	7	498	78	0	583	1	1	2	0	4	948
Total Volume	93	936	30	0	1059	287	21	75	0	383	24	1971	294	0	2289	9	4	15	0	28	3759
% App. Total	8.8	88.4	2.8	0		74.9	5.5	19.6	0		1	86.1	12.8	0		32.1	14.3	53.6	0		
PHF	.775	.925	.395	.000	.919	.875	.750	.815	.000	.887	.667	.921	.855	.000	.951	.450	.500	.625	.000	.636	.981

