



# Minnesota Dept. of Transportation

## Traffic Data Collection -Metro

TH-65 / CENTRAL AVE NE AT 40TH AVE NE  
 Ref.Pt; 004.510  
 Jamar # T-2638 CAH  
 TURN MOVEMENT COUNT

File Name : TH-65 AT 40TH AVE NE 2012  
 Site Code : 004.510  
 Start Date : 3/7/2012  
 Page No : 1

**Groups Printed- Unshifted**

Start Time	TH-65 / CENTRAL AVE NE Southbound				40TH AVE NE Westbound				TH-65 / CENTRAL AVE NE Northbound				40TH AVE NE Eastbound				Int. Total
	Right	Thru	Left	Peds	Right	Thru	Left	Peds	Right	Thru	Left	Peds	Right	Thru	Left	Peds	
06:00	1	75	7	1	4	5	0	3	1	29	3	0	3	4	2	1	139
06:15	2	100	11	0	6	7	1	2	0	35	4	0	11	4	6	0	189
06:30	6	132	6	1	9	6	1	6	0	49	9	0	11	6	2	0	244
06:45	5	119	17	1	2	6	6	2	2	56	3	0	11	3	6	0	239
Total	14	426	41	3	21	24	8	13	3	169	19	0	36	17	16	1	811
07:00	5	123	8	2	9	10	5	6	2	64	10	0	12	11	14	0	281
07:15	8	194	18	2	9	10	1	2	3	69	6	1	21	7	8	0	359
07:30	4	189	8	0	15	12	5	8	2	74	6	5	20	17	12	0	377
07:45	5	177	13	1	13	22	8	8	5	82	9	6	17	11	20	4	401
Total	22	683	47	5	46	54	19	24	12	289	31	12	70	46	54	4	1418
08:00	12	170	17	1	15	11	1	5	0	69	3	5	15	18	17	1	360
08:15	14	149	16	1	16	8	2	10	3	69	6	3	11	16	12	0	336
08:30	12	106	9	0	18	6	6	1	2	68	8	2	7	10	12	1	268
08:45	8	111	16	2	14	11	6	4	3	79	12	5	8	11	16	0	306
Total	46	536	58	4	63	36	15	20	8	285	29	15	41	55	57	2	1270
*** BREAK ***																	
11:00	24	117	20	6	19	20	9	9	6	90	16	3	7	12	18	6	382
11:15	26	104	19	14	8	17	4	2	7	109	13	2	7	9	30	6	377
11:30	26	111	28	3	23	8	8	2	10	118	18	5	15	15	18	2	410
11:45	24	132	23	5	17	21	7	8	7	132	13	18	18	20	18	1	464
Total	100	464	90	28	67	66	28	21	30	449	60	28	47	56	84	15	1633
12:00	16	122	20	8	34	12	8	7	7	109	16	22	28	16	25	1	451
12:15	24	146	18	6	15	12	12	10	10	156	16	14	20	7	22	0	488
12:30	24	139	16	11	21	13	11	6	9	121	14	5	19	12	39	0	460
12:45	24	93	13	7	23	9	19	7	10	129	15	1	18	14	18	0	400
Total	88	500	67	32	93	46	50	30	36	515	61	42	85	49	104	1	1799
*** BREAK ***																	
15:00	25	135	22	2	13	22	6	6	7	175	19	10	32	26	30	6	536
15:15	21	131	27	2	13	19	15	18	7	158	31	10	18	15	23	5	513
15:30	19	146	27	8	18	32	8	9	8	180	9	12	23	24	36	6	565
15:45	32	135	24	4	15	22	5	9	11	212	26	6	9	15	23	2	550
Total	97	547	100	16	59	95	34	42	33	725	85	38	82	80	112	19	2164
16:00	26	131	23	10	20	32	14	17	5	173	19	14	17	20	30	6	557
16:15	19	123	23	7	25	27	14	14	7	196	22	1	15	16	30	0	539
16:30	30	121	16	7	28	39	8	6	7	224	23	6	27	27	22	6	597
16:45	14	158	19	2	26	17	7	9	9	195	18	11	13	27	37	5	567
Total	89	533	81	26	99	115	43	46	28	788	82	32	72	90	119	17	2260
17:00	22	147	15	5	36	18	8	12	13	272	15	4	16	20	35	2	640
17:15	8	149	28	4	20	21	9	4	10	183	16	0	25	16	28	1	522
17:30	21	126	19	3	24	20	4	3	14	187	16	1	23	25	26	3	515
17:45	20	131	14	1	30	20	9	7	12	191	12	12	15	18	22	1	515
Total	71	553	76	13	110	79	30	26	49	833	59	17	79	79	111	7	2192
Grand Total	527	4242	560	127	558	515	227	222	199	4053	426	184	512	472	657	66	13547
Apprch %	9.7	77.7	10.3	2.3	36.7	33.8	14.9	14.6	4.1	83.4	8.8	3.8	30	27.7	38.5	3.9	
Total %	3.9	31.3	4.1	0.9	4.1	3.8	1.7	1.6	1.5	29.9	3.1	1.4	3.8	3.5	4.8	0.5	



# Minnesota Dept. of Transportation

## Traffic Data Collection -Metro

TH-65 / CENTRAL AVE NE AT 40TH AVE NE  
 Ref.Pt; 004.510  
 Jamar # T-2638 CAH  
 TURN MOVEMENT COUNT

File Name : TH-65 AT 40TH AVE NE 2012  
 Site Code : 004.510  
 Start Date : 3/7/2012  
 Page No : 2

Start Time	TH-65 / CENTRAL AVE NE Southbound					40TH AVE NE Westbound					TH-65 / CENTRAL AVE NE Northbound					40TH AVE NE Eastbound					Int. Total
	Right	Thru	Left	Peds	App. Total	Right	Thru	Left	Peds	App. Total	Right	Thru	Left	Peds	App. Total	Right	Thru	Left	Peds	App. Total	
Peak Hour Analysis From 06:00 to 08:45 - Peak 1 of 1																					
Peak Hour for Entire Intersection Begins at 07:15																					
07:15	8	194	18	2	222	9	10	1	2	22	3	69	6	1	79	21	7	8	0	36	359
07:30	4	189	8	0	201	15	12	5	8	40	2	74	6	5	87	20	17	12	0	49	377
07:45	5	177	13	1	196	13	22	8	8	51	5	82	9	6	102	17	11	20	4	52	401
08:00	12	170	17	1	200	15	11	1	5	32	0	69	3	5	77	15	18	17	1	51	360
Total Volume	29	730	56	4	819	52	55	15	23	145	10	294	24	17	345	73	53	57	5	188	1497
% App. Total	3.5	89.1	6.8	0.5		35.9	37.9	10.3	15.9		2.9	85.2	7	4.9		38.8	28.2	30.3	2.7		
PHF	.604	.941	.778	.500	.922	.867	.625	.469	.719	.711	.500	.896	.667	.708	.846	.869	.736	.713	.313	.904	.933

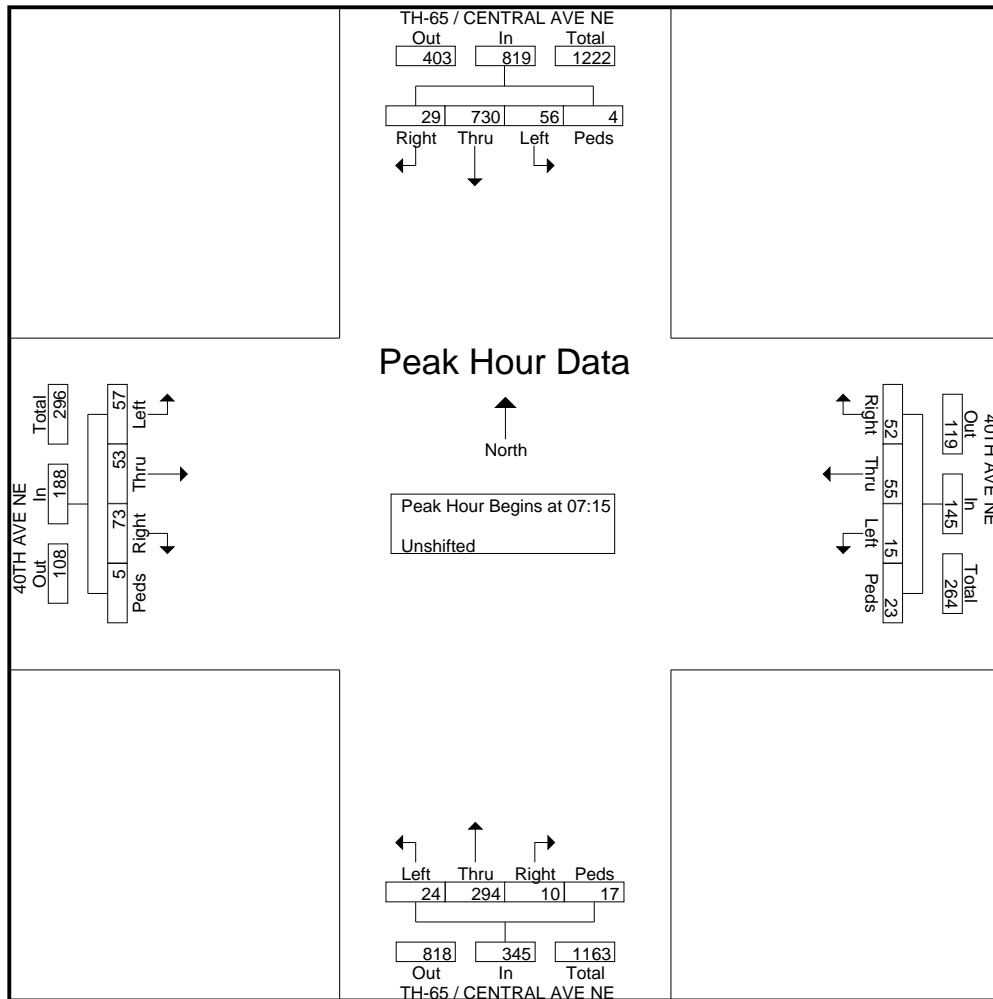



# Minnesota Dept. of Transportation

## Traffic Data Collection -Metro

TH-65 / CENTRAL AVE NE AT 40TH AVE NE  
 Ref.Pt; 004.510  
 Jamar # T-2638 CAH  
 TURN MOVEMENT COUNT

File Name : TH-65 AT 40TH AVE NE 2012  
 Site Code : 004.510  
 Start Date : 3/7/2012  
 Page No : 3

Start Time	TH-65 / CENTRAL AVE NE Southbound					40TH AVE NE Westbound					TH-65 / CENTRAL AVE NE Northbound					40TH AVE NE Eastbound					Int. Total
	Rig ht	Thr u	Left	Ped s	App. Total	Rig ht	Thr u	Left	Ped s	App. Total	Right	Thr u	Left	Peds	App. Total	Right	Thr u	Left	Peds	App. Total	
Peak Hour Analysis From 15:00 to 17:45 - Peak 1 of 1																					
Peak Hour for Entire Intersection Begins at 16:15																					
16:15	19	123	23	7	172	25	27	14	14	80	7	196	22	1	226	15	16	30	0	61	539
16:30	30	121	16	7	174	28	39	8	6	81	7	224	23	6	260	27	27	22	6	82	597
16:45	14	158	19	2	193	26	17	7	9	59	9	195	18	11	233	13	27	37	5	82	567
17:00	22	147	15	5	189	36	18	8	12	74	13	272	15	4	304	16	20	35	2	73	640
Total Volume	85	549	73	21	728	115	101	37	41	294	36	887	78	22	1023	71	90	124	13	298	2343
% App. Total	11.7	75.4	10	2.9		39.1	34.4	12.6	13.9		3.5	86.7	7.6	2.2		23.8	30.2	41.6	4.4		
PHF	.708	.869	.793	.750	.943	.799	.647	.661	.732	.907	.692	.815	.848	.500	.841	.657	.833	.838	.542	.909	.915

