



# MINNESOTA DEPT OF TRANSPORTATION

## TRAFFIC DATA COLLECTION - METRO

TH-61 at Broadway Ave / CSAH-2  
 Washington County, Forest Lake  
 COLLECTED BY:  
 Washington County, HTP0 Project #: 6359

File Name : TH-61 at Broadway AVE CSAH-2 2008  
 Site Code : 01300412  
 Start Date : 1/30/2008  
 Page No : 1

### Groups Printed- Unshifted

Start Time	TH-61 Southbound				Broadway Ave./CSAH-2 Westbound				TH-61 Northbound				Broadway Ave./CSAH-2 Eastbound				Int. Total
	Left	Thru	Right	Peds	Left	Thru	Right	Peds	Left	Thru	Right	Peds	Left	Thru	Right	Peds	
07:00	1	103	28	0	2	5	2	0	32	31	2	0	14	5	21	0	246
07:15	1	133	57	0	1	1	2	0	42	49	3	0	20	3	42	0	354
07:30	2	205	31	0	4	4	1	0	36	84	2	0	17	10	42	0	438
07:45	1	95	32	0	3	4	2	0	66	125	2	0	22	4	30	0	386
Total	5	536	148	0	10	14	7	0	176	289	9	0	73	22	135	0	1424
08:00	1	67	28	0	3	3	1	0	29	53	4	0	16	5	26	0	236
08:15	3	59	35	0	4	2	3	0	25	48	6	0	19	14	24	0	242
*** BREAK ***																	
Total	4	126	63	0	7	5	4	0	54	101	10	0	35	19	50	0	478
*** BREAK ***																	
16:15	5	93	48	0	15	8	9	0	45	132	6	0	74	13	71	0	519
16:30	7	122	41	0	11	15	4	0	69	120	9	0	76	12	53	0	539
16:45	4	101	60	0	13	18	3	0	64	139	5	0	76	12	58	0	553
Total	16	316	149	0	39	41	16	0	178	391	20	0	226	37	182	0	1611
17:00	5	91	46	0	17	22	12	2	63	137	6	0	79	20	68	0	568
17:15	4	109	45	0	10	18	5	0	60	128	3	0	84	20	71	0	557
17:30	2	67	57	1	10	12	8	1	62	97	12	0	79	9	47	0	464
Grand Total	36	1245	508	1	93	112	52	3	593	1143	60	0	576	127	553	0	5102
Apprch %	2	69.6	28.4	0.1	35.8	43.1	20	1.2	33	63.6	3.3	0	45.9	10.1	44	0	
Total %	0.7	24.4	10	0	1.8	2.2	1	0.1	11.6	22.4	1.2	0	11.3	2.5	10.8	0	



# MINNESOTA DEPT OF TRANSPORTATION

## TRAFFIC DATA COLLECTION - METRO

TH-61 at Broadway Ave / CSAH-2  
 Washington County, Forest Lake  
 COLLECTED BY:  
 Washington County, HTP0 Project #: 6359

File Name : TH-61 at Broadway AVE CSAH-2 2008  
 Site Code : 01300412  
 Start Date : 1/30/2008  
 Page No : 2

Start Time	TH-61 Southbound					Broadway Ave./CSAH-2 Westbound					TH-61 Northbound					Broadway Ave./CSAH-2 Eastbound					Int. Total
	Left	Thru	Right	Peds	App. Total	Left	Thru	Right	Peds	App. Total	Left	Thru	Right	Peds	App. Total	Left	Thru	Right	Peds	App. Total	
Peak Hour Analysis From 07:00 to 08:15 - Peak 1 of 1																					
Peak Hour for Entire Intersection Begins at 07:00																					
07:00	1	103	28	0	132	2	5	2	0	9	32	31	2	0	65	14	5	21	0	40	246
07:15	1	133	57	0	191	1	1	2	0	4	42	49	3	0	94	20	3	42	0	65	354
07:30	2	205	31	0	238	4	4	1	0	9	36	84	2	0	122	17	10	42	0	69	438
07:45	1	95	32	0	128	3	4	2	0	9	66	125	2	0	193	22	4	30	0	56	386
Total Volume	5	536	148	0	689	10	14	7	0	31	176	289	9	0	474	73	22	135	0	230	1424
% App. Total	0.7	77.8	21.5	0		32.3	45.2	22.6	0		37.1	61	1.9	0		31.7	9.6	58.7	0		
PHF	.625	.654	.649	.000	.724	.625	.700	.875	.000	.861	.667	.578	.750	.000	.614	.830	.550	.804	.000	.833	.813

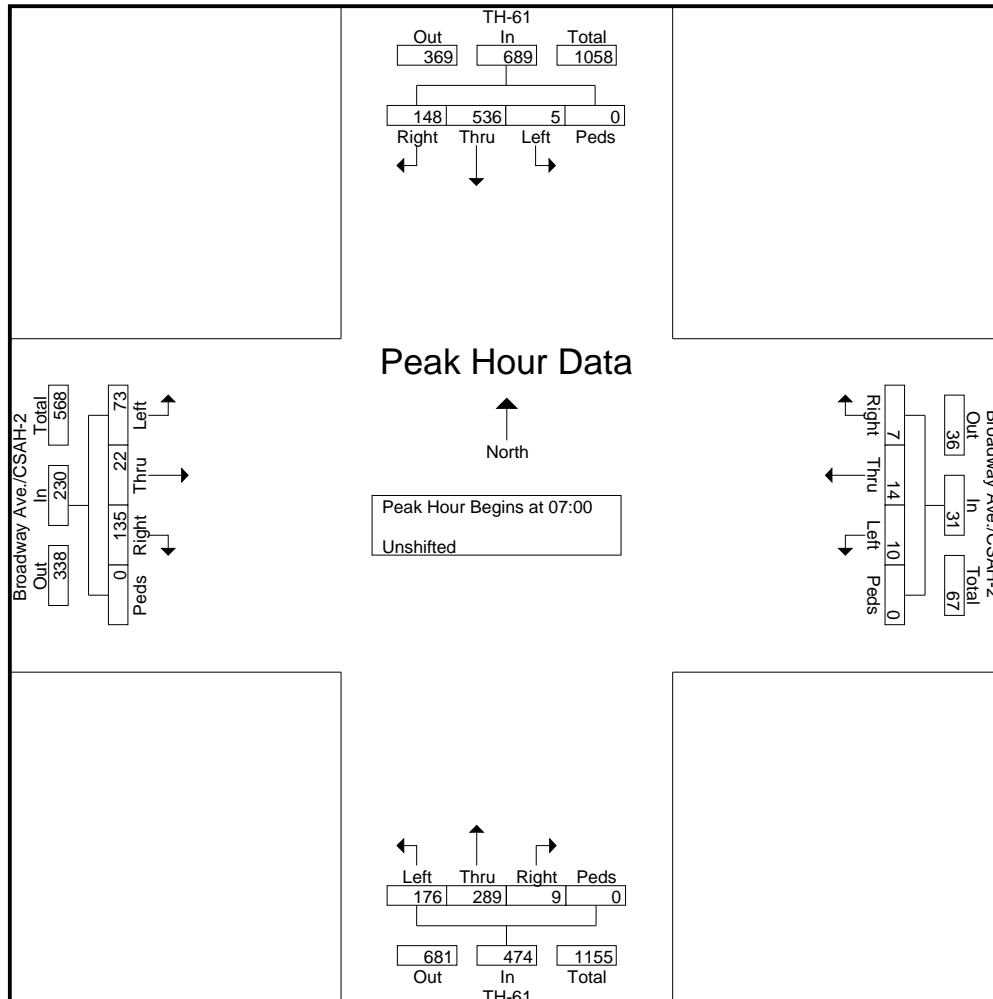



# MINNESOTA DEPT OF TRANSPORTATION

## TRAFFIC DATA COLLECTION - METRO

TH-61 at Broadway Ave / CSAH-2  
 Washington County, Forest Lake  
 COLLECTED BY:  
 Washington County, HTP0 Project #: 6359

File Name : TH-61 at Broadway AVE CSAH-2 2008  
 Site Code : 01300412  
 Start Date : 1/30/2008  
 Page No : 3

Start Time	TH-61 Southbound					Broadway Ave./CSAH-2 Westbound					TH-61 Northbound					Broadway Ave./CSAH-2 Eastbound					Int. Total
	Left	Thru	Right	Peds	App. Total	Left	Thru	Right	Peds	App. Total	Left	Thru	Right	Peds	App. Total	Left	Thru	Right	Peds	App. Total	
Peak Hour Analysis From 16:15 to 17:30 - Peak 1 of 1 Peak Hour for Entire Intersection Begins at 16:30																					
16:30	7	122	41	0	170	11	15	4	0	30	69	120	9	0	198	76	12	53	0	141	539
16:45	4	101	60	0	165	13	18	3	0	34	64	139	5	0	208	76	12	58	0	146	553
17:00	5	91	46	0	142	17	22	12	2	53	63	137	6	0	206	79	20	68	0	167	568
17:15	4	109	45	0	158	10	18	5	0	33	60	128	3	0	191	84	20	71	0	175	557
Total Volume	20	423	192	0	635	51	73	24	2	150	256	524	23	0	803	315	64	250	0	629	2217
% App. Total	3.1	66.6	30.2	0		34	48.7	16	1.3		31.9	65.3	2.9	0		50.1	10.2	39.7	0		
PHF	.714	.867	.800	.000	.934	.750	.830	.500	.250	.708	.928	.942	.639	.000	.965	.938	.800	.880	.000	.899	.976

