



Minnesota Dept. of Transportation

Traffic Data Collection -Metro

TH-61 at 202nd ST N
 Ref.Pt; 158.429
 Jamar # T-2638 CAH
 TURN MOVEMENT COUNT

File Name : th-61 at 202nd st n 2012
 Site Code : 158.429
 Start Date : 1/12/2012
 Page No : 1

Groups Printed- Unshifted

Start Time	TH-61 Southbound				202ND ST N Westbound				TH-61 Northbound				202ND ST N Eastbound				Int. Total
	Right	Thru	Left	Peds	Right	Thru	Left	Peds	Right	Thru	Left	Peds	Right	Thru	Left	Peds	
06:00	16	35	2	0	8	6	4	0	1	14	1	0	0	1	3	0	91
06:15	3	52	0	0	7	0	6	0	1	12	0	0	0	0	1	0	82
06:30	15	57	2	0	7	4	10	0	1	20	3	0	1	0	0	0	120
06:45	4	54	1	0	4	0	10	0	1	29	0	0	0	0	1	0	104
Total	38	198	5	0	26	10	30	0	4	75	4	0	1	1	5	0	397
07:00	2	20	1	0	1	3	5	0	4	22	0	0	0	0	0	0	58
07:15	1	70	0	0	7	2	13	0	7	43	0	0	0	3	1	0	147
07:30	5	74	2	0	7	2	17	0	8	59	0	0	0	2	1	0	177
07:45	10	54	7	0	5	6	13	0	5	42	0	0	1	1	1	0	145
Total	18	218	10	0	20	13	48	0	24	166	0	0	1	6	3	0	527
08:00	1	42	2	0	3	0	5	0	4	27	0	0	0	0	3	0	87
08:15	3	29	1	0	5	1	7	0	0	40	0	0	0	1	0	0	87
08:30	1	43	1	0	6	1	3	0	0	42	2	0	0	0	2	0	101
08:45	3	55	1	0	12	1	8	0	1	46	0	0	0	0	5	0	132
Total	8	169	5	0	26	3	23	0	5	155	2	0	0	1	10	0	407
*** BREAK ***																	
15:00	3	54	6	0	3	3	2	0	5	67	0	0	1	2	4	0	150
15:15	4	30	7	0	6	3	1	0	3	49	0	0	1	3	7	0	114
15:30	5	33	4	0	5	2	3	0	3	46	1	0	0	3	3	0	108
15:45	13	62	7	0	7	0	2	0	12	99	0	0	0	3	7	0	212
Total	25	179	24	0	21	8	8	0	23	261	1	0	2	11	21	0	584
16:00	6	62	10	0	6	1	7	0	8	88	0	0	1	3	8	0	200
16:15	11	72	7	0	3	2	4	0	2	92	1	0	2	2	12	0	210
16:30	7	67	11	0	8	2	4	0	8	110	1	0	1	10	14	0	243
16:45	6	61	4	0	2	3	5	0	5	91	0	0	1	4	9	0	191
Total	30	262	32	0	19	8	20	0	23	381	2	0	5	19	43	0	844
17:00	1	66	9	0	7	2	6	0	5	87	0	0	0	9	15	0	207
17:15	0	44	12	0	12	0	2	0	7	67	1	0	0	2	5	0	152
17:30	5	47	7	0	9	2	5	0	16	82	0	0	2	4	20	0	199
17:45	5	40	8	0	6	1	4	0	13	73	0	0	1	3	6	0	160
Total	11	197	36	0	34	5	17	0	41	309	1	0	3	18	46	0	718
Grand Total	130	1223	112	0	146	47	146	0	120	1347	10	0	12	56	128	0	3477
Apprch %	8.9	83.5	7.6	0	43.1	13.9	43.1	0	8.1	91.2	0.7	0	6.1	28.6	65.3	0	
Total %	3.7	35.2	3.2	0	4.2	1.4	4.2	0	3.5	38.7	0.3	0	0.3	1.6	3.7	0	



Minnesota Dept. of Transportation

Traffic Data Collection -Metro

TH-61 at 202nd ST N
 Ref.Pt; 158.429
 Jamar # T-2638 CAH
 TURN MOVEMENT COUNT

File Name : th-61 at 202nd st n 2012
 Site Code : 158.429
 Start Date : 1/12/2012
 Page No : 2

Start Time	TH-61 Southbound					202ND ST N Westbound					TH-61 Northbound					202ND ST N Eastbound					Int. Total
	Right	Thru	Left	Peds	App. Total	Right	Thru	Left	Peds	App. Total	Right	Thru	Left	Peds	App. Total	Right	Thru	Left	Peds	App. Total	
Peak Hour Analysis From 06:00 to 08:45 - Peak 1 of 1																					
Peak Hour for Entire Intersection Begins at 07:15																					
07:15	1	70	0	0	71	7	2	13	0	22	7	43	0	0	50	0	3	1	0	4	147
07:30	5	74	2	0	81	7	2	17	0	26	8	59	0	0	67	0	2	1	0	3	177
07:45	10	54	7	0	71	5	6	13	0	24	5	42	0	0	47	1	1	1	0	3	145
08:00	1	42	2	0	45	3	0	5	0	8	4	27	0	0	31	0	0	3	0	3	87
Total Volume	17	240	11	0	268	22	10	48	0	80	24	171	0	0	195	1	6	6	0	13	556
% App. Total	6.3	89.6	4.1	0		27.5	12.5	60	0		12.3	87.7	0	0		7.7	46.2	46.2	0		
PHF	.425	.811	.393	.000	.827	.786	.417	.706	.000	.769	.750	.725	.000	.000	.728	.250	.500	.500	.000	.813	.785

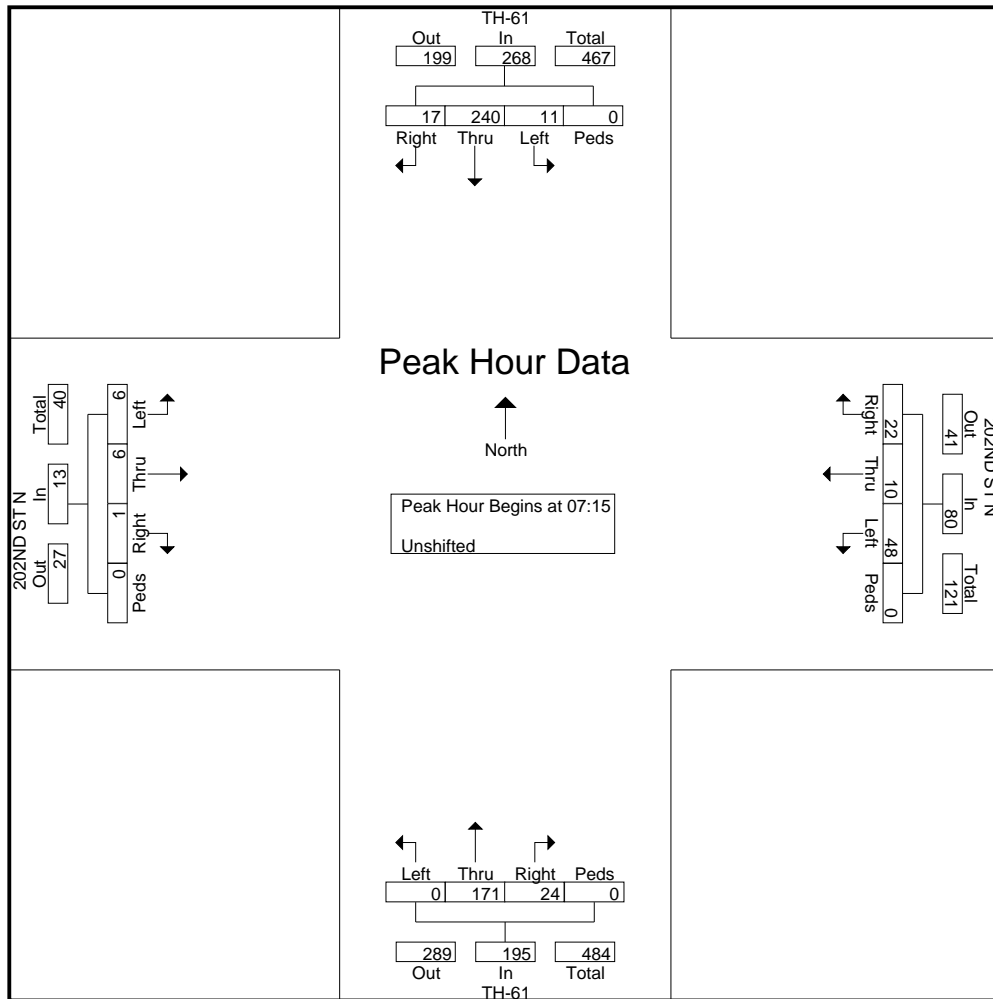



Minnesota Dept. of Transportation

Traffic Data Collection -Metro

TH-61 at 202nd ST N
 Ref.Pt; 158.429
 Jamar # T-2638 CAH
 TURN MOVEMENT COUNT

File Name : th-61 at 202nd st n 2012
 Site Code : 158.429
 Start Date : 1/12/2012
 Page No : 3

Start Time	TH-61 Southbound					202ND ST N Westbound					TH-61 Northbound					202ND ST N Eastbound					Int. Total
	Rig ht	Thr u	Left	Ped s	App. Total	Rig ht	Thr u	Left	Ped s	App. Total	Right	Thr u	Left	Peds	App. Total	Right	Thr u	Left	Peds	App. Total	
Peak Hour Analysis From 15:00 to 17:45 - Peak 1 of 1																					
Peak Hour for Entire Intersection Begins at 15:45																					
15:45	13	62	7	0	82	7	0	2	0	9	12	99	0	0	111	0	3	7	0	10	212
16:00	6	62	10	0	78	6	1	7	0	14	8	88	0	0	96	1	3	8	0	12	200
16:15	11	72	7	0	90	3	2	4	0	9	2	92	1	0	95	2	2	12	0	16	210
16:30	7	67	11	0	85	8	2	4	0	14	8	110	1	0	119	1	10	14	0	25	243
Total Volume	37	263	35	0	335	24	5	17	0	46	30	389	2	0	421	4	18	41	0	63	865
% App. Total	11	78.5	10.4	0		52.2	10.9	37	0		7.1	92.4	0.5	0		6.3	28.6	65.1	0		
PHF	.712	.913	.795	.000	.931	.750	.625	.607	.000	.821	.625	.884	.500	.000	.884	.500	.450	.732	.000	.630	.890

