



MINNESOTA DEPT OF TRANSPORTATION

TRAFFIC DATA COLLECTION - METRO

TH-61 at Frenchman Rd / 145th St N
 Ref.Pt.: 152.578
 Data by: Alliant Inc.
 TURN MOVEMENT COUNT

File Name : TH-61 at 145th Ave N Frenchmand Rd 2008
 Site Code : 00000122
 Start Date : 9/23/2008
 Page No : 1

Groups Printed- Unshifted

Start Time	TH-61 Southbound				Frenchman Rd / 145th St N Westbound				TH-61 Northbound				Frenchman Rd / 145th St N Eastbound				Int. Total
	Left	Thru	Right	Peds	Left	Thru	Right	Peds	Left	Thru	Right	Peds	Left	Thru	Right	Peds	
06:00	0	55	64	0	0	0	0	0	45	6	0	0	9	0	31	0	210
06:15	0	107	66	0	0	0	1	0	40	20	0	0	16	0	33	0	283
06:30	0	104	55	0	0	0	0	0	52	22	0	0	14	2	55	0	304
06:45	0	136	50	0	0	1	0	0	47	40	0	0	18	1	80	0	373
Total	0	402	235	0	0	1	1	0	184	88	0	0	57	3	199	0	1170
07:00	0	150	54	0	0	0	0	0	44	32	0	0	28	0	70	0	378
07:15	0	99	39	0	0	0	0	0	44	40	0	0	23	0	54	0	299
07:30	0	96	40	0	0	1	0	0	29	30	0	0	18	0	44	0	258
07:45	0	63	31	0	0	1	0	0	35	37	0	0	19	1	23	0	210
Total	0	408	164	0	0	2	0	0	152	139	0	0	88	1	191	0	1145
08:00	0	94	54	0	0	1	0	0	40	45	2	0	35	1	39	0	311
08:15	0	82	51	0	0	0	0	0	43	37	0	0	23	0	56	0	292
08:30	0	69	49	0	2	3	0	0	45	30	3	0	19	0	46	0	266
08:45	0	56	47	0	1	3	1	0	37	47	4	0	36	2	42	0	276
Total	0	301	201	0	3	7	1	0	165	159	9	0	113	3	183	0	1145
09:00	0	59	43	0	0	1	0	0	47	42	0	0	21	2	41	0	256
09:15	0	60	46	0	2	0	0	0	37	50	0	0	37	0	39	0	271
*** BREAK ***																	
Total	0	119	89	0	2	1	0	0	84	92	0	0	58	2	80	0	527
*** BREAK ***																	
10:30	1	60	43	0	1	0	0	0	37	47	2	0	25	0	32	0	248
10:45	1	51	35	0	2	1	1	0	36	40	0	0	33	1	38	0	239
Total	2	111	78	0	3	1	1	0	73	87	2	0	58	1	70	0	487
11:00	2	56	36	0	0	0	1	0	37	65	0	0	34	1	35	0	267
11:15	0	85	44	0	0	1	1	0	27	60	0	0	37	1	47	0	303
11:30	0	54	62	0	0	0	0	0	36	43	0	0	46	0	39	0	280
11:45	1	63	37	0	0	0	1	0	48	81	0	0	39	0	45	0	315
Total	3	258	179	0	0	1	3	0	148	249	0	0	156	2	166	0	1165
12:00	0	61	40	0	9	0	0	0	33	55	1	0	46	1	41	0	287
12:15	2	55	44	0	1	0	0	0	46	67	1	0	30	0	42	0	288
12:30	2	58	42	0	2	1	0	0	38	68	1	0	45	0	45	0	302
12:45	2	58	38	0	0	2	0	0	39	67	0	0	42	0	29	0	277
Total	6	232	164	0	12	3	0	0	156	257	3	0	163	1	157	0	1154
13:00	0	52	27	0	0	0	0	0	31	70	0	0	54	0	39	0	273
13:15	0	62	46	0	1	1	0	1	42	72	2	1	43	1	35	0	307
*** BREAK ***																	
Total	0	114	73	0	1	1	0	1	73	142	2	1	97	1	74	0	580
*** BREAK ***																	
14:30	1	63	32	0	4	0	0	0	43	70	3	0	53	0	57	0	326
14:45	0	62	43	0	0	0	0	0	47	76	1	0	54	0	54	1	338
Total	1	125	75	0	4	0	0	0	90	146	4	0	107	0	111	1	664
15:00	1	55	38	0	4	4	0	1	57	93	0	0	82	1	51	0	387
15:15	0	73	38	0	0	0	0	0	76	111	0	0	88	1	81	0	468
15:30	0	67	50	0	4	0	1	2	80	117	1	0	80	7	75	0	484
15:45	0	75	39	0	1	0	1	0	77	119	0	0	102	0	74	0	488
Total	1	270	165	0	9	4	2	3	290	440	1	0	352	9	281	0	1827



MINNESOTA DEPT OF TRANSPORTATION

TRAFFIC DATA COLLECTION - METRO

TH-61 at Frenchman Rd / 145th St N

Ref.Pt.: 152.578

Data by: Alliant Inc.

TURN MOVEMENT COUNT

File Name : TH-61 at 145th Ave N Frenchmand Rd 2008

Site Code : 00000122

Start Date : 9/23/2008

Page No : 2

Groups Printed- Unshifted

Start Time	TH-61 Southbound				Frenchman Rd / 145th St N Westbound				TH-61 Northbound				Frenchman Rd / 145th St N Eastbound				Int. Total
	Left	Thru	Right	Peds	Left	Thru	Right	Peds	Left	Thru	Right	Peds	Left	Thru	Right	Peds	
16:00	1	62	46	1	1	0	0	0	82	169	0	0	92	0	70	0	524
16:15	0	55	64	1	0	1	0	0	83	125	1	0	84	1	81	1	497
16:30	0	68	64	0	7	5	0	1	77	128	1	0	107	1	104	0	563
16:45	0	83	63	0	3	1	0	0	91	129	2	0	98	14	82	0	566
Total	1	268	237	2	11	7	0	1	333	551	4	0	381	16	337	1	2150
17:00	2	72	48	0	0	0	0	0	82	133	1	0	73	6	91	0	508
17:15	0	47	29	0	0	0	0	0	78	153	1	0	95	0	54	0	457
17:30	0	65	52	0	0	0	1	0	102	148	0	0	79	2	80	0	529
17:45	0	61	33	0	0	0	0	1	54	102	0	0	64	1	58	0	374
Total	2	245	162	0	0	0	1	1	316	536	2	0	311	9	283	0	1868
Grand Total	16	2853	1822	2	45	28	9	6	2064	2886	27	1	1941	48	2132	2	13882
Apprch %	0.3	60.8	38.8	0	51.1	31.8	10.2	6.8	41.5	58	0.5	0	47.1	1.2	51.7	0	
Total %	0.1	20.6	13.1	0	0.3	0.2	0.1	0	14.9	20.8	0.2	0	14	0.3	15.4	0	



MINNESOTA DEPT OF TRANSPORTATION

TRAFFIC DATA COLLECTION - METRO

TH-61 at Frenchman Rd / 145th St N
 Ref.Pt.: 152.578
 Data by: Alliant Inc.
 TURN MOVEMENT COUNT

File Name : TH-61 at 145th Ave N Frenchmand Rd 2008
 Site Code : 00000122
 Start Date : 9/23/2008
 Page No : 3

Start Time	TH-61 Southbound					Frenchman Rd / 145th St N Westbound					TH-61 Northbound					Frenchman Rd / 145th St N Eastbound					Int. Total
	Left	Thru	Right	Peds	App. Total	Left	Thru	Right	Peds	App. Total	Left	Thru	Right	Peds	App. Total	Left	Thru	Right	Peds	App. Total	
Peak Hour Analysis From 06:00 to 08:45 - Peak 1 of 1																					
Peak Hour for Entire Intersection Begins at 06:30																					
06:30	0	104	55	0	159	0	0	0	0	0	52	22	0	0	74	14	2	55	0	71	304
06:45	0	136	50	0	186	0	1	0	0	1	47	40	0	0	87	18	1	80	0	99	373
07:00	0	150	54	0	204	0	0	0	0	0	44	32	0	0	76	28	0	70	0	98	378
07:15	0	99	39	0	138	0	0	0	0	0	44	40	0	0	84	23	0	54	0	77	299
Total Volume	0	489	198	0	687	0	1	0	0	1	187	134	0	0	321	83	3	259	0	345	1354
% App. Total	0	71.2	28.8	0		0	100	0	0		58.3	41.7	0	0		24.1	0.9	75.1	0		
PHF	.000	.815	.900	.000	.842	.000	.250	.000	.000	.250	.899	.838	.000	.000	.922	.741	.375	.809	.000	.871	.896

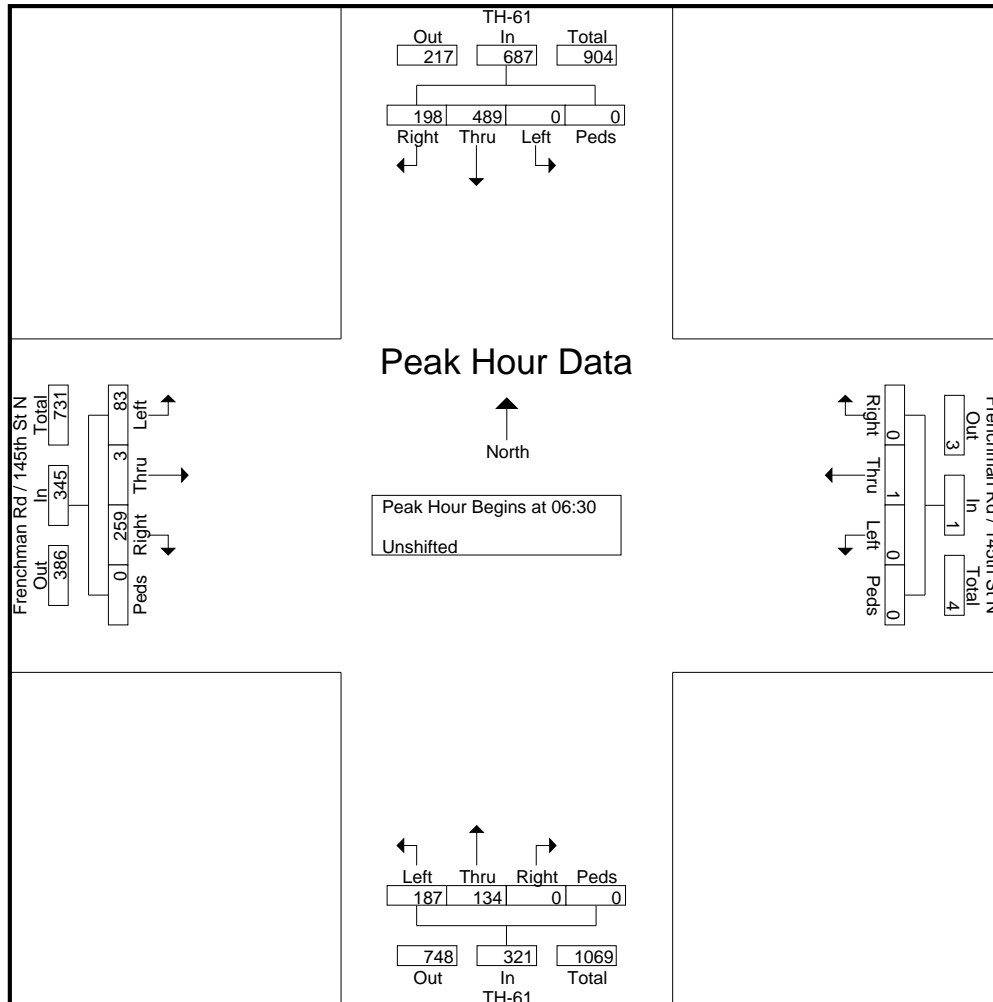



MINNESOTA DEPT OF TRANSPORTATION

TRAFFIC DATA COLLECTION - METRO

TH-61 at Frenchman Rd / 145th St N
 Ref.Pt.: 152.578
 Data by: Alliant Inc.
 TURN MOVEMENT COUNT

File Name : TH-61 at 145th Ave N Frenchmand Rd 2008
 Site Code : 00000122
 Start Date : 9/23/2008
 Page No : 4

Start Time	TH-61 Southbound					Frenchman Rd / 145th St N Westbound					TH-61 Northbound					Frenchman Rd / 145th St N Eastbound					Int. Total
	Left	Thru	Right	Peds	App. Total	Left	Thru	Right	Peds	App. Total	Left	Thru	Right	Peds	App. Total	Left	Thru	Right	Peds	App. Total	
16:00	1	62	46	1	110	1	0	0	0	1	82	169	0	0	251	92	0	70	0	162	524
16:15	0	55	64	1	120	0	1	0	0	1	83	125	1	0	209	84	1	81	1	167	497
16:30	0	68	64	0	132	7	5	0	1	13	77	128	1	0	206	107	1	104	0	212	563
16:45	0	83	63	0	146	3	1	0	0	4	91	129	2	0	222	98	14	82	0	194	566
Total Volume	1	268	237	2	508	11	7	0	1	19	333	551	4	0	888	381	16	337	1	735	2150
% App. Total	0.2	52.8	46.7	0.4		57.9	36.8	0	5.3		37.5	62	0.5	0		51.8	2.2	45.9	0.1		
PHF	.250	.807	.926	.500	.870	.393	.350	.000	.250	.365	.915	.815	.500	.000	.884	.890	.286	.810	.250	.867	.950

Peak Hour Analysis From 15:00 to 17:45 - Peak 1 of 1

Peak Hour for Entire Intersection Begins at 16:00

