

Alliant Engineering Inc Minneapolis, MN 55415

TH-61 at Co.Rd.. E
Ref.Pt. 144.467
data by: Alliant Engineering
TURN MOVEMENT COUNT

File Name : TH-61 at Co Rd E 2008
Site Code : 00000110
Start Date : 9/11/2008
Page No : 1

Groups Printed- Unshifted - Bank 1

Start Time	TH-61 Southbound				Co.Rd.E Westbound				TH-61 Northbound				Co.Rd.E Eastbound				Int. Total
	Left	Thru	Right	Peds	Left	Thru	Right	Peds	Left	Thru	Right	Peds	Left	Thru	Right	Peds	
06:00	7	129	7	0	20	16	16	0	3	48	9	0	4	19	18	0	296
06:15	21	187	12	0	34	27	0	0	10	45	3	0	9	23	8	0	379
06:30	9	295	21	1	58	52	2	1	11	53	14	0	9	37	19	0	582
06:45	19	340	22	0	34	47	4	0	21	73	20	0	6	64	20	0	670
Total	56	951	62	1	146	142	22	1	45	219	46	0	28	143	65	0	1927
07:00	16	394	28	0	57	61	1	0	13	56	15	0	19	85	15	0	760
07:15	48	422	40	0	60	67	0	0	19	74	22	0	11	123	31	0	917
07:30	42	339	18	0	57	107	6	0	42	105	12	0	14	85	32	0	859
07:45	27	241	28	0	36	145	10	0	32	101	20	0	21	70	22	0	753
Total	133	1396	114	0	210	380	17	0	106	336	69	0	65	363	100	0	3289
08:00	14	262	43	0	40	51	2	0	23	70	18	0	26	42	38	0	629
08:15	20	234	32	0	38	73	4	0	33	81	22	0	20	55	28	0	640
08:30	11	199	39	0	42	64	5	0	38	74	13	1	16	74	42	0	618
08:45	19	180	36	0	44	55	8	0	27	96	18	0	18	56	37	0	594
Total	64	875	150	0	164	243	19	0	121	321	71	1	80	227	145	0	2481
09:00	20	157	21	0	34	57	10	0	21	77	30	0	24	73	22	0	546
09:15	32	141	29	0	38	49	18	0	38	88	14	0	24	52	28	0	551
*** BREAK ***																	
Total	52	298	50	0	72	106	28	0	59	165	44	0	48	125	50	0	1097
*** BREAK ***																	
10:30	25	141	26	0	26	65	12	0	53	110	20	1	18	47	34	0	578
10:45	21	132	30	0	45	43	14	0	32	100	14	0	23	58	28	0	540
Total	46	273	56	0	71	108	26	0	85	210	34	1	41	105	62	0	1118
11:00	26	148	26	0	27	62	19	0	22	105	21	0	20	53	33	0	562
11:15	19	183	36	0	31	69	16	0	42	95	19	0	30	60	33	0	633
11:30	28	163	20	0	16	71	21	0	46	109	15	0	34	59	45	0	627
11:45	28	165	26	0	39	66	20	0	46	104	24	0	36	70	31	0	655
Total	101	659	108	0	113	268	76	0	156	413	79	0	120	242	142	0	2477
12:00	35	139	27	0	30	64	18	0	41	132	25	0	40	55	44	0	650
12:15	19	152	28	0	33	55	14	0	41	113	19	0	27	62	38	0	601
12:30	19	197	38	0	31	87	15	0	41	112	22	0	32	62	40	0	696
12:45	20	161	24	0	36	71	18	0	33	123	24	0	41	80	39	0	670
Total	93	649	117	0	130	277	65	0	156	480	90	0	140	259	161	0	2617
13:00	26	162	24	0	37	96	11	0	51	115	21	0	26	57	58	0	684
13:15	14	150	27	0	33	57	6	0	49	115	19	0	33	52	38	0	593
*** BREAK ***																	
Total	40	312	51	0	70	153	17	0	100	230	40	0	59	109	96	0	1277
*** BREAK ***																	
14:30	21	179	23	0	32	94	14	0	52	162	29	0	34	53	43	0	736
14:45	21	153	26	0	41	122	15	0	63	212	38	0	51	71	42	0	855
Total	42	332	49	0	73	216	29	0	115	374	67	0	85	124	85	0	1591
15:00	19	162	23	0	35	69	22	0	63	158	33	0	43	89	44	0	760
15:15	22	170	35	0	32	67	23	0	68	164	37	0	40	95	40	0	793
15:30	29	174	26	0	33	83	21	0	47	193	30	0	61	93	40	0	830
15:45	19	179	19	0	32	101	17	0	63	196	39	0	54	85	55	2	861
Total	89	685	103	0	132	320	83	0	241	711	139	0	198	362	179	2	3244

Alliant Engineering Inc Minneapolis, MN 55415

TH-61 at Co.Rd.. E
Ref.Pt. 144.467
data by: Alliant Engineering
TURN MOVEMENT COUNT

File Name : TH-61 at Co Rd E 2008
Site Code : 00000110
Start Date : 9/11/2008
Page No : 2

Groups Printed- Unshifted - Bank 1

Start Time	TH-61 Southbound				Co.Rd.E Westbound				TH-61 Northbound				Co.Rd.E Eastbound				Int. Total
	Left	Thru	Right	Peds	Left	Thru	Right	Peds	Left	Thru	Right	Peds	Left	Thru	Right	Peds	
16:00	30	155	32	0	33	87	18	0	67	194	51	0	54	121	40	0	882
16:15	20	182	29	0	30	81	14	0	75	236	39	0	49	89	45	1	890
16:30	28	183	24	0	27	97	23	0	73	246	49	0	57	116	52	0	975
16:45	22	174	25	0	24	102	14	0	93	258	41	0	67	125	36	1	982
Total	100	694	110	0	114	367	69	0	308	934	180	0	227	451	173	2	3729
17:00	28	180	24	0	30	82	23	0	81	261	55	0	66	129	37	0	996
17:15	16	174	20	0	35	97	26	0	77	236	32	1	80	107	34	0	935
17:30	28	134	24	0	28	93	21	0	73	196	42	0	79	139	39	0	896
17:45	26	132	12	0	26	78	19	0	68	184	63	0	61	124	38	0	831
Total	98	620	80	0	119	350	89	0	299	877	192	1	286	499	148	0	3658
18:00	29	134	30	0	31	84	12	0	40	187	30	0	49	91	41	0	758
Grand Total	943	7878	1080	1	1445	3014	552	1	1831	5457	1081	3	1426	3100	1447	4	29263
Apprch %	9.5	79.6	10.9	0	28.8	60.1	11	0	21.9	65.2	12.9	0	23.9	51.9	24.2	0.1	
Total %	3.2	26.9	3.7	0	4.9	10.3	1.9	0	6.3	18.6	3.7	0	4.9	10.6	4.9	0	
Unshifted	915	7760	1053	1	1415	2951	536	1	1809	5384	1060	3	1410	3042	1427	4	28771
% Unshifted	97	98.5	97.5	100	97.9	97.9	97.1	100	98.8	98.7	98.1	100	98.9	98.1	98.6	100	98.3
Bank 1	28	118	27	0	30	63	16	0	22	73	21	0	16	58	20	0	492
% Bank 1	3	1.5	2.5	0	2.1	2.1	2.9	0	1.2	1.3	1.9	0	1.1	1.9	1.4	0	1.7

Alliant Engineering Inc Minneapolis, MN 55415

TH-61 at Co.Rd.. E
 Ref.Pt. 144.467
 data by: Alliant Engineering
 TURN MOVEMENT COUNT

File Name : TH-61 at Co Rd E 2008
 Site Code : 00000110
 Start Date : 9/11/2008
 Page No : 3

Start Time	TH-61 Southbound					Co.Rd.E Westbound					TH-61 Northbound					Co.Rd.E Eastbound					Int. Total
	Left	Thru	Right	Peds	App. Total	Left	Thru	Right	Peds	App. Total	Left	Thru	Right	Peds	App. Total	Left	Thru	Right	Peds	App. Total	
Peak Hour Analysis From 06:00 to 09:15 - Peak 1 of 1																					
Peak Hour for Entire Intersection Begins at 07:00																					
07:00	16	394	28	0	438	57	61	1	0	119	13	56	15	0	84	19	85	15	0	119	760
07:15	48	422	40	0	510	60	67	0	0	127	19	74	22	0	115	11	123	31	0	165	917
07:30	42	339	18	0	399	57	107	6	0	170	42	105	12	0	159	14	85	32	0	131	859
07:45	27	241	28	0	296	36	145	10	0	191	32	101	20	0	153	21	70	22	0	113	753
Total Volume	133	1396	114	0	1643	210	380	17	0	607	106	336	69	0	511	65	363	100	0	528	3289
% App. Total	8.1	85	6.9	0		34.6	62.6	2.8	0		20.7	65.8	13.5	0		12.3	68.8	18.9	0		
PHF	.693	.827	.713	.000	.805	.875	.655	.425	.000	.795	.631	.800	.784	.000	.803	.774	.738	.781	.000	.800	.897

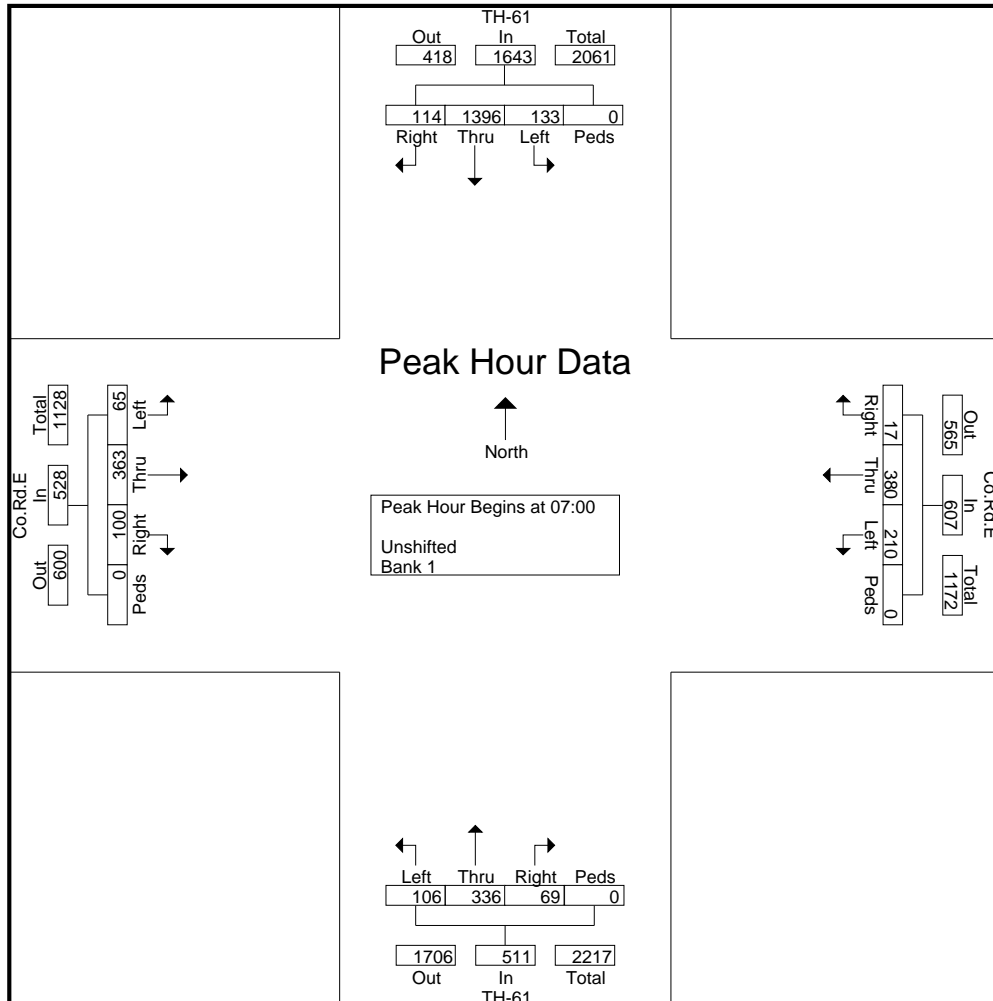

Alliant Engineering Inc Minneapolis, MN 55415

TH-61 at Co.Rd.. E
 Ref.Pt. 144.467
 data by: Alliant Engineering
 TURN MOVEMENT COUNT

File Name : TH-61 at Co Rd E 2008
 Site Code : 00000110
 Start Date : 9/11/2008
 Page No : 4

Start Time	TH-61 Southbound					Co.Rd.E Westbound					TH-61 Northbound					Co.Rd.E Eastbound					Int. Total
	Left	Thru	Right	Peds	App. Total	Left	Thru	Right	Peds	App. Total	Left	Thru	Right	Peds	App. Total	Left	Thru	Right	Peds	App. Total	
Peak Hour Analysis From 14:30 to 18:00 - Peak 1 of 1																					
Peak Hour for Entire Intersection Begins at 16:30																					
16:30	28	183	24	0	235	27	97	23	0	147	73	246	49	0	368	57	116	52	0	225	975
16:45	22	174	25	0	221	24	102	14	0	140	93	258	41	0	392	67	125	36	1	229	982
17:00	28	180	24	0	232	30	82	23	0	135	81	261	55	0	397	66	129	37	0	232	996
17:15	16	174	20	0	210	35	97	26	0	158	77	236	32	1	346	80	107	34	0	221	935
Total Volume	94	711	93	0	898	116	378	86	0	580	324	1001	177	1	1503	270	477	159	1	907	3888
% App. Total	10.5	79.2	10.4	0		20	65.2	14.8	0		21.6	66.6	11.8	0.1		29.8	52.6	17.5	0.1		
PHF	.839	.971	.930	.000	.955	.829	.926	.827	.000	.918	.871	.959	.805	.250	.946	.844	.924	.764	.250	.977	.976

