



minnesota dept of transportation

TRAFFIC DATA COLLECTION - METRO

TH-61 at Willow Lake Blvd (WBL)
 Ref.Pt.: 144.214
 Data By; Alliant Inc.
 Turn Movement Count

File Name : TH-61 at Willow Lake Blvd 2008
 Site Code : 00000109
 Start Date : 9/18/2008
 Page No : 1

Groups Printed- Unshifted

Start Time	TH-61 Southbound				Willow Lake Blvd Westbound				TH-61 Northbound				Willow Lake Blvd Eastbound				Int. Total
	Left	Thru	Right	Peds	Left	Thru	Right	Peds	Left	Thru	Right	Peds	Left	Thru	Right	Peds	
06:00	0	169	1	0	0	0	0	0	19	33	0	0	0	0	2	0	224
06:15	0	226	3	0	0	0	0	0	25	65	2	0	0	0	8	0	329
06:30	0	318	2	0	0	0	0	0	27	84	0	0	1	0	5	0	437
06:45	0	363	5	0	0	0	0	0	40	109	0	0	0	0	7	0	524
Total	0	1076	11	0	0	0	0	0	111	291	2	0	1	0	22	0	1514
07:00	0	376	7	0	0	0	0	0	23	84	0	0	0	0	18	0	508
07:15	0	359	6	0	0	0	0	0	34	100	0	0	2	0	8	0	509
07:30	0	407	3	0	0	0	0	0	53	123	0	0	2	0	12	0	600
07:45	0	352	1	0	0	0	0	0	35	115	0	0	2	0	19	0	524
Total	0	1494	17	0	0	0	0	0	145	422	0	0	6	0	57	0	2141
08:00	0	282	7	0	0	0	0	0	51	124	0	0	4	0	17	0	485
08:15	0	241	4	0	0	0	0	0	25	128	1	0	0	0	17	0	416
08:30	0	234	1	0	0	0	0	0	17	135	0	0	0	0	25	0	412
08:45	0	226	7	0	0	0	0	0	23	160	0	0	2	0	8	0	426
Total	0	983	19	0	0	0	0	0	116	547	1	0	6	0	67	0	1739
09:00	0	198	1	0	0	0	0	0	22	131	0	0	1	0	20	0	373
09:15	0	215	5	0	0	0	0	0	20	100	0	0	1	0	5	0	346
*** BREAK ***																	
Total	0	413	6	0	0	0	0	0	42	231	0	0	2	0	25	0	719
*** BREAK ***																	
10:30	0	176	5	0	0	0	0	0	19	114	0	0	7	0	15	0	336
10:45	0	190	7	0	0	0	0	0	13	159	0	0	3	0	15	0	387
Total	0	366	12	0	0	0	0	0	32	273	0	0	10	0	30	0	723
11:00	0	169	7	0	0	0	0	0	21	157	0	0	9	0	13	0	376
11:15	0	197	4	0	0	0	0	0	20	162	0	0	2	0	38	0	423
11:30	0	170	1	0	0	0	0	0	19	124	1	0	3	0	28	0	346
11:45	0	194	2	0	0	0	0	0	10	163	0	0	10	0	40	0	419
Total	0	730	14	0	0	0	0	0	70	606	1	0	24	0	119	0	1564
12:00	0	193	7	0	0	0	0	0	23	144	0	0	15	0	50	0	432
12:15	0	207	10	0	0	0	0	0	20	193	0	0	6	0	23	0	459
12:30	0	191	5	0	0	0	0	0	35	173	0	0	6	0	24	0	434
12:45	0	206	12	0	0	0	0	0	23	159	0	0	5	0	14	0	419
Total	0	797	34	0	0	0	0	0	101	669	0	0	32	0	111	0	1744
13:00	0	154	8	0	0	0	0	0	31	184	0	0	3	0	24	0	404
13:15	0	218	9	0	0	0	0	0	25	192	0	0	6	0	11	0	461
*** BREAK ***																	
Total	0	372	17	0	0	0	0	0	56	376	0	0	9	0	35	0	865
*** BREAK ***																	
14:30	0	170	3	0	0	0	0	0	25	195	0	0	2	0	22	0	417
14:45	0	198	8	0	0	0	0	0	24	257	0	0	8	0	29	0	524
Total	0	368	11	0	0	0	0	0	49	452	0	0	10	0	51	0	941
15:00	0	187	5	1	0	0	0	0	25	214	0	0	3	0	69	0	504
15:15	0	227	4	0	0	0	0	0	30	247	1	0	2	0	33	0	544
15:30	0	269	1	0	0	0	0	0	36	269	0	0	9	0	42	0	626
15:45	0	249	2	0	0	0	0	0	17	321	0	0	1	0	36	1	627
Total	0	932	12	1	0	0	0	0	108	1051	1	0	15	0	180	1	2301



MINNESOTA DEPT OF TRANSPORTATION

TRAFFIC DATA COLLECTION - METRO

TH-61 at Willow Lake Blvd (WBL)
 Ref.Pt.: 144.214
 Data By; Alliant Inc.
 Turn Movement Count

File Name : TH-61 at Willow Lake Blvd 2008
 Site Code : 00000109
 Start Date : 9/18/2008
 Page No : 2

Groups Printed- Unshifted

Start Time	TH-61 Southbound				Willow Lake Blvd Westbound				TH-61 Northbound				Willow Lake Blvd Eastbound				Int. Total
	Left	Thru	Right	Peds	Left	Thru	Right	Peds	Left	Thru	Right	Peds	Left	Thru	Right	Peds	
16:00	0	255	5	0	0	0	0	0	18	412	0	0	11	0	39	0	740
16:15	0	207	4	0	0	0	0	0	20	266	0	0	4	0	23	0	524
16:30	0	259	5	0	0	0	0	0	19	373	0	0	15	0	82	0	753
16:45	0	188	3	0	0	0	0	0	19	382	0	0	3	0	56	1	652
Total	0	909	17	0	0	0	0	0	76	1433	0	0	33	0	200	1	2669
17:00	0	212	3	0	0	0	0	0	18	351	0	0	6	0	61	0	651
17:15	0	197	6	0	0	0	0	0	18	322	0	0	5	0	40	0	588
17:30	0	173	3	0	0	0	0	0	9	300	0	0	9	0	32	0	526
17:45	0	199	1	0	0	0	0	0	6	276	0	0	1	0	16	0	499
Total	0	781	13	0	0	0	0	0	51	1249	0	0	21	0	149	0	2264
Grand Total	0	9221	183	1	0	0	0	0	957	7600	5	0	169	0	1046	2	19184
Apprch %	0	98	1.9	0	0	0	0	0	11.2	88.8	0.1	0	13.9	0	85.9	0.2	
Total %	0	48.1	1	0	0	0	0	0	5	39.6	0	0	0.9	0	5.5	0	



MINNESOTA DEPT OF TRANSPORTATION

TRAFFIC DATA COLLECTION - METRO

TH-61 at Willow Lake Blvd (WBL)
 Ref.Pt.: 144.214
 Data By: Alliant Inc.
 Turn Movement Count

File Name : TH-61 at Willow Lake Blvd 2008
 Site Code : 00000109
 Start Date : 9/18/2008
 Page No : 3

Start Time	TH-61 Southbound					Willow Lake Blvd Westbound					TH-61 Northbound					Willow Lake Blvd Eastbound					Int. Total
	Left	Thru	Right	Peds	App. Total	Left	Thru	Right	Peds	App. Total	Left	Thru	Right	Peds	App. Total	Left	Thru	Right	Peds	App. Total	
Peak Hour Analysis From 06:00 to 09:15 - Peak 1 of 1																					
Peak Hour for Entire Intersection Begins at 06:45																					
06:45	0	363	5	0	368	0	0	0	0	0	40	109	0	0	149	0	0	7	0	7	524
07:00	0	376	7	0	383	0	0	0	0	0	23	84	0	0	107	0	0	18	0	18	508
07:15	0	359	6	0	365	0	0	0	0	0	34	100	0	0	134	2	0	8	0	10	509
07:30	0	407	3	0	410	0	0	0	0	0	53	123	0	0	176	2	0	12	0	14	600
Total Volume	0	1505	21	0	1526	0	0	0	0	0	150	416	0	0	566	4	0	45	0	49	2141
% App. Total	0	98.6	1.4	0		0	0	0	0		26.5	73.5	0	0		8.2	0	91.8	0		
PHF	.000	.924	.750	.000	.930	.000	.000	.000	.000	.000	.708	.846	.000	.000	.804	.500	.000	.625	.000	.681	.892

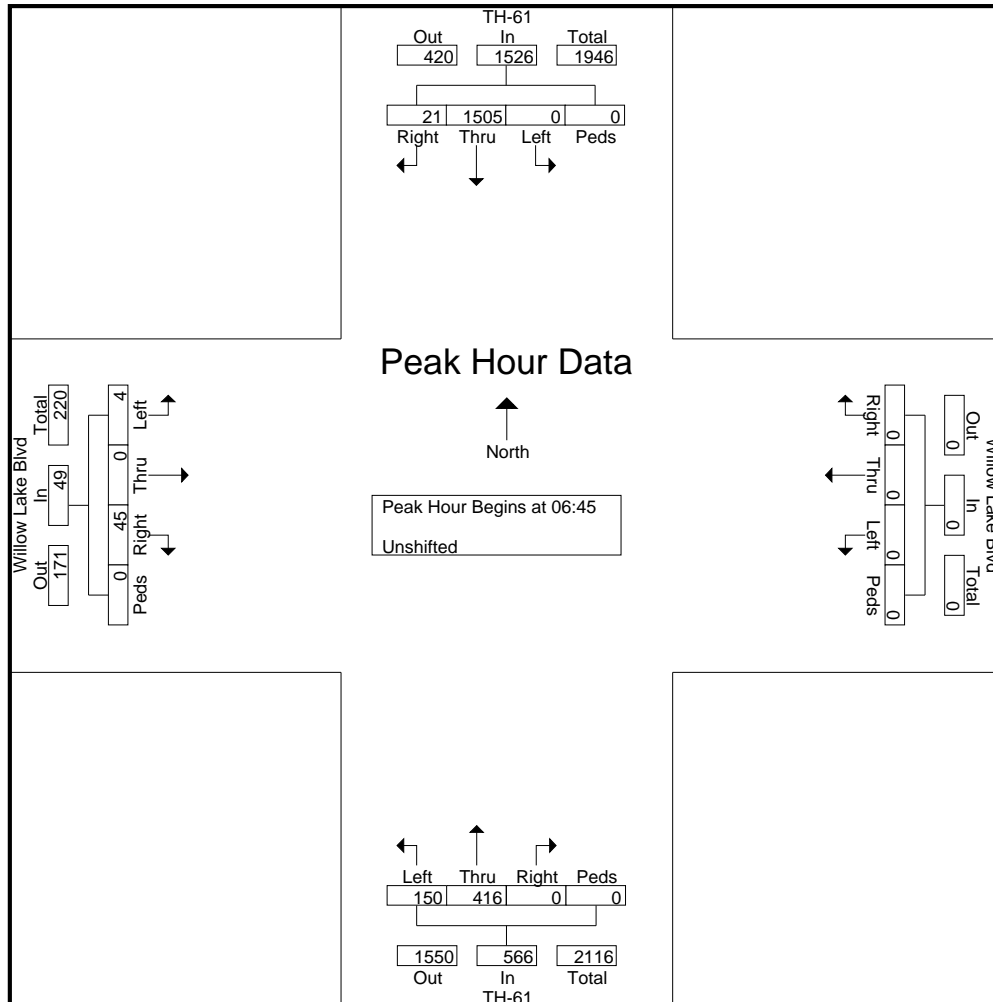



MINNESOTA DEPT OF TRANSPORTATION

TRAFFIC DATA COLLECTION - METRO

TH-61 at Willow Lake Blvd (WBL)
 Ref.Pt.: 144.214
 Data By; Alliant Inc.
 Turn Movement Count

File Name : TH-61 at Willow Lake Blvd 2008
 Site Code : 00000109
 Start Date : 9/18/2008
 Page No : 4

Start Time	TH-61 Southbound					Willow Lake Blvd Westbound					TH-61 Northbound					Willow Lake Blvd Eastbound					Int. Total
	Left	Thru	Right	Peds	App. Total	Left	Thru	Right	Peds	App. Total	Left	Thru	Right	Peds	App. Total	Left	Thru	Right	Peds	App. Total	

Peak Hour Analysis From 14:30 to 17:45 - Peak 1 of 1

Peak Hour for Entire Intersection Begins at 16:00

16:00	0	255	5	0	260	0	0	0	0	0	18	412	0	0	430	11	0	39	0	50	740
16:15	0	207	4	0	211	0	0	0	0	0	20	266	0	0	286	4	0	23	0	27	524
16:30	0	259	5	0	264	0	0	0	0	0	19	373	0	0	392	15	0	82	0	97	753
16:45	0	188	3	0	191	0	0	0	0	0	19	382	0	0	401	3	0	56	1	60	652
Total Volume	0	909	17	0	926	0	0	0	0	0	76	1433	0	0	1509	33	0	200	1	234	2669
% App. Total	0	98.2	1.8	0		0	0	0	0		5	95	0	0		14.1	0	85.5	0.4		
PHF	.000	.877	.850	.000	.877	.000	.000	.000	.000	.000	.950	.870	.000	.000	.877	.550	.000	.610	.250	.603	.886

