



MINNESOTA DEPT OF TRANSPORTATION

TRAFFIC DATA COLLECTION - METRO

TH-61 at Beam Ave. MAPLEWOOD
 Ref.Pt.: 142.823
 Data by: Alliant Inc.
 TURN MOVEMENT COUNT

File Name : TH-61 at Beam Ave
 Site Code : 00000104
 Start Date : 9/24/2008
 Page No : 1

Groups Printed- Unshifted

Start Time	TH-61 Southbound				Beam Ave. Westbound				TH-61 Northbound				Beam Ave. Eastbound				Int. Total
	Left	Thru	Right	Peds	Left	Thru	Right	Peds	Left	Thru	Right	Peds	Left	Thru	Right	Peds	
06:00	14	115	3	0	16	0	8	0	1	42	18	0	3	0	3	0	223
06:15	16	148	3	0	24	2	10	1	2	77	25	1	1	1	8	0	319
06:30	32	243	3	0	32	0	8	1	0	96	34	0	6	1	9	0	465
06:45	50	276	8	0	32	1	14	0	4	136	53	0	3	6	16	0	599
Total	112	782	17	0	104	3	40	2	7	351	130	1	13	8	36	0	1606
07:00	47	329	6	0	44	5	15	0	10	118	43	0	5	5	16	0	643
07:15	50	372	6	0	58	2	9	0	7	129	61	0	4	3	12	0	713
07:30	51	385	8	0	56	2	21	0	8	140	68	0	5	7	17	0	768
07:45	68	306	11	0	54	3	13	0	7	128	93	0	4	7	13	0	707
Total	216	1392	31	0	212	12	58	0	32	515	265	0	18	22	58	0	2831
08:00	43	275	8	0	61	8	18	1	10	105	73	0	6	8	20	0	636
08:15	56	169	6	0	45	2	20	0	10	112	89	0	5	8	13	0	535
08:30	62	172	3	0	41	5	22	0	12	116	71	0	7	6	6	0	523
08:45	77	150	3	0	35	2	29	0	8	94	84	0	6	10	8	0	506
Total	238	766	20	0	182	17	89	1	40	427	317	0	24	32	47	0	2200
09:00	60	123	8	0	54	7	33	0	11	109	68	0	5	10	13	1	502
09:15	56	98	6	0	54	3	49	0	13	122	105	0	1	5	14	0	526
*** BREAK ***																	
Total	116	221	14	0	108	10	82	0	24	231	173	0	6	15	27	1	1028
*** BREAK ***																	
10:30	69	93	6	0	84	3	63	0	6	89	88	0	3	10	15	0	529
10:45	68	99	8	0	60	4	65	0	8	99	84	0	3	4	4	0	506
Total	137	192	14	0	144	7	128	0	14	188	172	0	6	14	19	0	1035
11:00	86	132	8	0	83	6	61	0	7	119	100	0	6	14	11	1	634
11:15	89	107	5	0	74	7	63	0	7	144	120	0	12	3	10	0	641
11:30	89	128	5	0	85	14	79	0	12	138	109	0	11	8	7	0	685
11:45	93	127	13	0	78	9	71	0	7	133	131	0	7	6	10	0	685
Total	357	494	31	0	320	36	274	0	33	534	460	0	36	31	38	1	2645
12:00	72	107	10	0	97	6	100	0	13	108	116	0	11	13	11	0	664
12:15	83	111	7	0	98	11	92	0	11	129	94	1	4	8	8	0	657
12:30	64	117	4	0	128	12	91	0	4	125	102	0	5	11	10	0	673
12:45	61	128	6	0	113	9	84	0	11	149	130	0	5	6	6	0	708
Total	280	463	27	0	436	38	367	0	39	511	442	1	25	38	35	0	2702
13:00	46	114	15	0	120	8	82	0	4	126	104	0	4	14	11	0	648
13:15	62	95	6	0	90	5	77	0	7	126	106	0	19	3	7	0	603
*** BREAK ***																	
Total	108	209	21	0	210	13	159	0	11	252	210	0	23	17	18	0	1251
*** BREAK ***																	
14:30	46	120	4	0	102	5	93	0	15	183	119	0	7	7	10	0	711
14:45	76	147	11	0	109	6	90	0	11	170	137	0	6	7	11	0	781
Total	122	267	15	0	211	11	183	0	26	353	256	0	13	14	21	0	1492
15:00	66	145	10	0	99	14	129	1	5	192	122	0	4	6	13	1	807
15:15	69	122	8	0	75	9	103	0	8	192	130	0	7	9	10	0	742
15:30	63	195	9	0	88	12	92	1	15	223	114	1	13	9	17	0	852
15:45	63	180	8	0	107	13	92	0	13	235	145	0	10	6	8	0	880
Total	261	642	35	0	369	48	416	2	41	842	511	1	34	30	48	1	3281



MINNESOTA DEPT OF TRANSPORTATION

TRAFFIC DATA COLLECTION - METRO

TH-61 at Beam Ave. MAPLEWOOD

Ref.Pt.: 142.823

Data by: Alliant Inc.

TURN MOVEMENT COUNT

File Name : TH-61 at Beam Ave

Site Code : 00000104

Start Date : 9/24/2008

Page No : 2

Groups Printed- Unshifted

Start Time	TH-61 Southbound				Beam Ave. Westbound				TH-61 Northbound				Beam Ave. Eastbound				Int. Total
	Left	Thru	Right	Peds	Left	Thru	Right	Peds	Left	Thru	Right	Peds	Left	Thru	Right	Peds	
16:00	58	154	7	1	85	5	124	0	19	235	109	0	17	12	5	0	831
16:15	75	149	2	0	75	10	86	0	16	243	91	2	13	10	14	0	786
16:30	66	197	4	0	137	6	93	0	18	258	103	0	13	9	6	0	910
16:45	122	138	5	0	127	10	89	1	22	275	154	0	12	15	14	0	984
Total	321	638	18	1	424	31	392	1	75	1011	457	2	55	46	39	0	3511
17:00	76	163	5	0	140	11	96	0	21	307	147	0	22	7	8	0	1003
17:15	114	138	5	0	97	8	94	0	19	289	133	0	6	6	8	0	917
17:30	63	172	5	0	92	18	98	0	12	273	182	0	9	12	7	0	943
17:45	89	168	10	0	92	10	88	1	22	260	157	1	7	14	15	0	934
Total	342	641	25	0	421	47	376	1	74	1129	619	1	44	39	38	0	3797
Grand Total	2610	6707	268	1	3141	273	2564	7	416	6344	4012	6	297	306	424	3	27379
Apprch %	27.2	70	2.8	0	52.5	4.6	42.8	0.1	3.9	58.9	37.2	0.1	28.8	29.7	41.2	0.3	
Total %	9.5	24.5	1	0	11.5	1	9.4	0	1.5	23.2	14.7	0	1.1	1.1	1.5	0	



MINNESOTA DEPT OF TRANSPORTATION

TRAFFIC DATA COLLECTION - METRO

TH-61 at Beam Ave. MAPLEWOOD
 Ref.Pt.: 142.823
 Data by: Alliant Inc.
 TURN MOVEMENT COUNT

File Name : TH-61 at Beam Ave
 Site Code : 00000104
 Start Date : 9/24/2008
 Page No : 3

Start Time	TH-61 Southbound					Beam Ave. Westbound					TH-61 Northbound					Beam Ave. Eastbound					Int. Total
	Left	Thru	Right	Peds	App. Total	Left	Thru	Right	Peds	App. Total	Left	Thru	Right	Peds	App. Total	Left	Thru	Right	Peds	App. Total	
Peak Hour Analysis From 06:00 to 09:15 - Peak 1 of 1																					
Peak Hour for Entire Intersection Begins at 07:00																					
07:00	47	329	6	0	382	44	5	15	0	64	10	118	43	0	171	5	5	16	0	26	643
07:15	50	372	6	0	428	58	2	9	0	69	7	129	61	0	197	4	3	12	0	19	713
07:30	51	385	8	0	444	56	2	21	0	79	8	140	68	0	216	5	7	17	0	29	768
07:45	68	306	11	0	385	54	3	13	0	70	7	128	93	0	228	4	7	13	0	24	707
Total Volume	216	1392	31	0	1639	212	12	58	0	282	32	515	265	0	812	18	22	58	0	98	2831
% App. Total	13.2	84.9	1.9	0		75.2	4.3	20.6	0		3.9	63.4	32.6	0		18.4	22.4	59.2	0		
PHF	.794	.904	.705	.000	.923	.914	.600	.690	.000	.892	.800	.920	.712	.000	.890	.900	.786	.853	.000	.845	.922

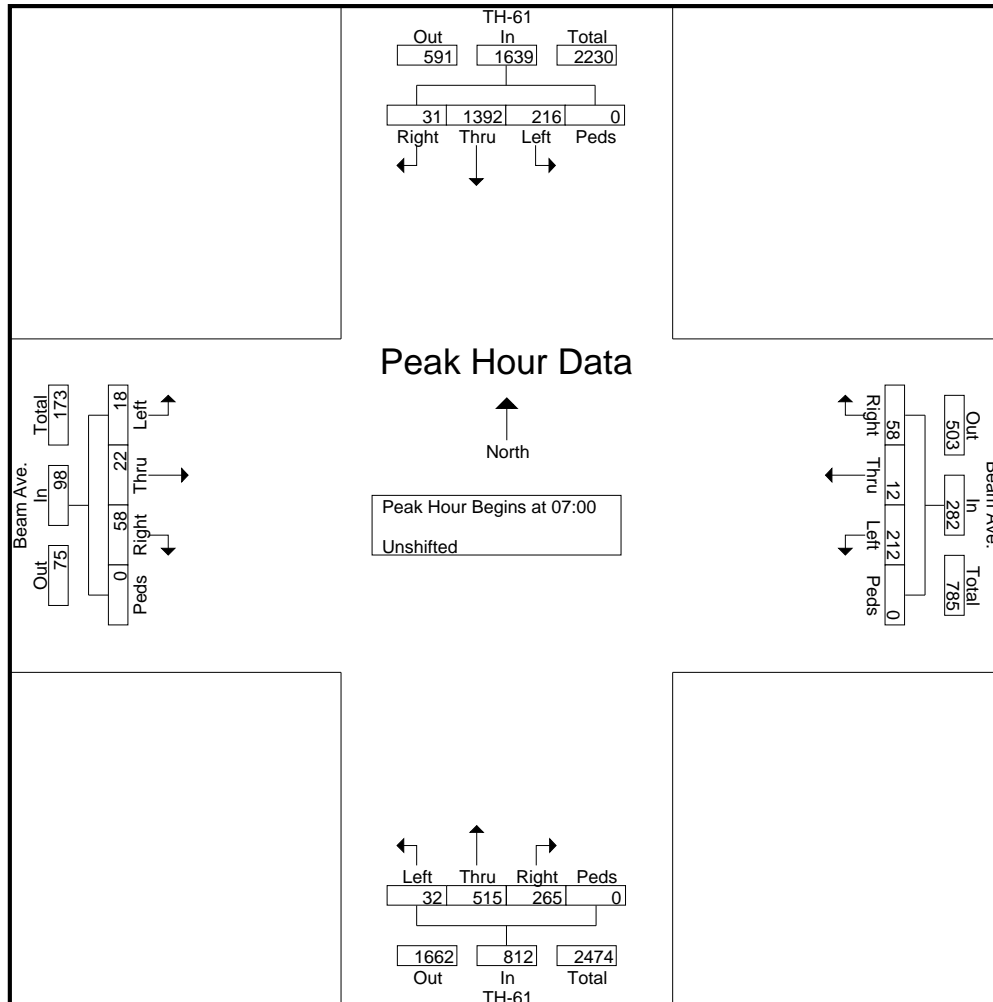



MINNESOTA DEPT OF TRANSPORTATION

TRAFFIC DATA COLLECTION - METRO

TH-61 at Beam Ave. MAPLEWOOD
 Ref.Pt.: 142.823
 Data by: Alliant Inc.
 TURN MOVEMENT COUNT

File Name : TH-61 at Beam Ave
 Site Code : 00000104
 Start Date : 9/24/2008
 Page No : 4

Start Time	TH-61 Southbound					Beam Ave. Westbound					TH-61 Northbound					Beam Ave. Eastbound					Int. Total
	Left	Thru	Right	Peds	App. Total	Left	Thru	Right	Peds	App. Total	Left	Thru	Right	Peds	App. Total	Left	Thru	Right	Peds	App. Total	
Peak Hour Analysis From 14:30 to 17:45 - Peak 1 of 1																					
Peak Hour for Entire Intersection Begins at 16:45																					
16:45	122	138	5	0	265	127	10	89	1	227	22	275	154	0	451	12	15	14	0	41	984
17:00	76	163	5	0	244	140	11	96	0	247	21	307	147	0	475	22	7	8	0	37	1003
17:15	114	138	5	0	257	97	8	94	0	199	19	289	133	0	441	6	6	8	0	20	917
17:30	63	172	5	0	240	92	18	98	0	208	12	273	182	0	467	9	12	7	0	28	943
Total Volume	375	611	20	0	1006	456	47	377	1	881	74	1144	616	0	1834	49	40	37	0	126	3847
% App. Total	37.3	60.7	2	0		51.8	5.3	42.8	0.1		4	62.4	33.6	0		38.9	31.7	29.4	0		
PHF	.768	.888	1.000	.000	.949	.814	.653	.962	.250	.892	.841	.932	.846	.000	.965	.557	.667	.661	.000	.768	.959

