



MINNESOTA DEPT OF TRANSPORTATION

TRAFFIC DATA COLLECTION - METRO

2nd St E at Great River Rd E, Hastings
 Ref.Pt.:
 JAMAR # 631 / T-2638 RE/DS
 TURN MOVEMENT COUNT

File Name : 2nd St E at Great River Rd E 2008
 Site Code : 00000000
 Start Date : 4/23/2008
 Page No : 1

Groups Printed- Cars & Trucks

Start Time	E Road under Bridge Southbound				2nd St E Westbound				Great River Rd E Northbound				2nd St E Eastbound				Int. Total
	Left	Thru	Right	Peds	Left	Thru	Right	Peds	Left	Thru	Right	Peds	Left	Thru	Right	Peds	
06:00	0	0	0	0	4	13	0	0	3	0	0	0	0	10	13	0	43
06:15	0	0	0	0	2	11	0	0	5	0	0	0	0	16	22	0	56
06:30	0	0	0	0	1	25	0	3	8	0	0	0	0	23	28	1	89
06:45	0	0	0	0	3	21	0	0	11	0	1	1	0	22	20	0	79
Total	0	0	0	0	10	70	0	3	27	0	1	1	0	71	83	1	267
07:00	0	0	0	0	1	24	0	1	5	1	2	0	0	15	30	0	79
07:15	0	0	0	0	1	30	0	0	10	0	0	0	0	26	36	1	104
07:30	0	0	0	0	1	42	0	2	7	0	0	0	1	32	30	0	115
07:45	0	0	0	0	4	21	0	0	5	0	2	0	1	32	19	0	84
Total	0	0	0	0	7	117	0	3	27	1	4	0	2	105	115	1	382
08:00	0	0	0	0	0	18	1	0	5	0	1	0	0	27	25	1	78
08:15	0	0	0	0	5	22	0	1	3	0	9	0	1	35	28	0	104
08:30	0	0	0	0	0	41	0	0	2	0	2	0	1	35	23	0	104
08:45	0	0	0	0	0	35	0	1	1	0	2	0	0	35	17	0	91
Total	0	0	0	0	5	116	1	2	11	0	14	0	2	132	93	1	377
*** BREAK ***																	
14:45	0	0	0	0	3	46	0	0	4	1	3	0	5	56	18	0	136
Total	0	0	0	0	3	46	0	0	4	1	3	0	5	56	18	0	136
15:00	0	0	0	0	1	36	1	0	8	1	0	0	0	54	35	0	136
15:15	0	0	0	0	3	48	1	0	4	0	6	0	2	69	40	0	173
15:30	0	0	0	0	2	50	1	0	6	0	4	0	2	48	45	0	158
15:45	0	0	0	0	4	45	0	0	7	2	5	0	1	47	43	0	154
Total	0	0	0	0	10	179	3	0	25	3	15	0	5	218	163	0	621
16:00	0	0	0	0	7	37	0	0	3	1	5	0	3	45	35	0	136
16:15	0	0	0	0	5	39	0	0	9	0	8	0	1	33	40	2	137
16:30	0	0	0	0	1	40	1	0	2	1	2	0	0	63	42	1	153
16:45	0	0	0	0	3	49	1	0	6	0	13	0	1	49	54	0	176
Total	0	0	0	0	16	165	2	0	20	2	28	0	5	190	171	3	602
17:00	0	0	0	0	3	48	0	0	4	0	2	0	1	44	63	0	165
17:15	0	0	0	0	3	53	1	0	6	1	7	0	0	38	51	0	160
17:30	0	0	0	0	1	23	2	0	3	1	3	0	1	32	46	0	112
17:45	0	0	0	0	0	23	3	0	6	0	6	0	2	45	84	0	169
Total	0	0	0	0	7	147	6	0	19	2	18	0	4	159	244	0	606
Grand Total	0	0	0	0	58	840	12	8	133	9	83	1	23	931	887	6	2991
Apprch %	0	0	0	0	6.3	91.5	1.3	0.9	58.8	4	36.7	0.4	1.2	50.4	48	0.3	
Total %	0	0	0	0	1.9	28.1	0.4	0.3	4.4	0.3	2.8	0	0.8	31.1	29.7	0.2	



MINNESOTA DEPT OF TRANSPORTATION

TRAFFIC DATA COLLECTION - METRO

2nd St E at Great River Rd E, Hastings
 Ref.Pt.:
 JAMAR # 631 / T-2638 RE/DS
 TURN MOVEMENT COUNT

File Name : 2nd St E at Great River Rd E 2008
 Site Code : 00000000
 Start Date : 4/23/2008
 Page No : 2

Start Time	E Road under Bridge Southbound					2nd St E Westbound					Great River Rd E Northbound					2nd St E Eastbound					Int. Total
	Left	Thru	Right	Peds	App. Total	Left	Thru	Right	Peds	App. Total	Left	Thru	Right	Peds	App. Total	Left	Thru	Right	Peds	App. Total	
Peak Hour Analysis From 06:00 to 08:45 - Peak 1 of 1																					
Peak Hour for Entire Intersection Begins at 07:00																					
07:00	0	0	0	0	0	1	24	0	1	26	5	1	2	0	8	0	15	30	0	45	79
07:15	0	0	0	0	0	1	30	0	0	31	10	0	0	0	10	0	26	36	1	63	104
07:30	0	0	0	0	0	1	42	0	2	45	7	0	0	0	7	1	32	30	0	63	115
07:45	0	0	0	0	0	4	21	0	0	25	5	0	2	0	7	1	32	19	0	52	84
Total Volume	0	0	0	0	0	7	117	0	3	127	27	1	4	0	32	2	105	115	1	223	382
% App. Total																					
PHF	.000	.000	.000	.000	.000	.438	.696	.000	.375	.706	.675	.250	.500	.000	.800	.500	.820	.799	.250	.885	.830

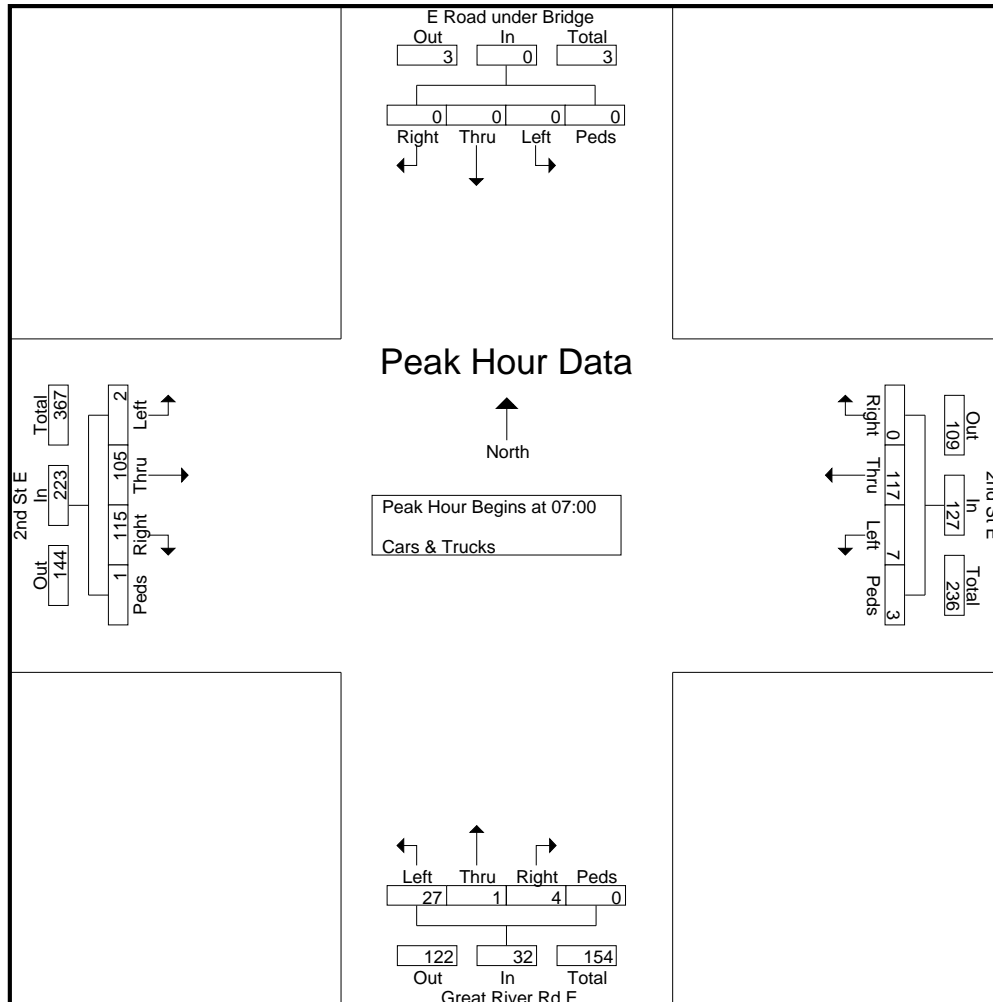



MINNESOTA DEPT OF TRANSPORTATION

TRAFFIC DATA COLLECTION - METRO

2nd St E at Great River Rd E, Hastings
 Ref.Pt.:
 JAMAR # 631 / T-2638 RE/DS
 TURN MOVEMENT COUNT

File Name : 2nd St E at Great River Rd E 2008
 Site Code : 00000000
 Start Date : 4/23/2008
 Page No : 3

Start Time	E Road under Bridge Southbound					2nd St E Westbound					Great River Rd E Northbound					2nd St E Eastbound					Int. Total
	Left	Thru	Right	Peds	App. Total	Left	Thru	Right	Peds	App. Total	Left	Thru	Right	Peds	App. Total	Left	Thru	Right	Peds	App. Total	
Peak Hour Analysis From 15:00 to 17:45 - Peak 1 of 1																					
Peak Hour for Entire Intersection Begins at 16:30																					
16:30	0	0	0	0	0	1	40	1	0	42	2	1	2	0	5	0	63	42	1	106	153
16:45	0	0	0	0	0	3	49	1	0	53	6	0	13	0	19	1	49	54	0	104	176
17:00	0	0	0	0	0	3	48	0	0	51	4	0	2	0	6	1	44	63	0	108	165
17:15	0	0	0	0	0	3	53	1	0	57	6	1	7	0	14	0	38	51	0	89	160
Total Volume	0	0	0	0	0	10	190	3	0	203	18	2	24	0	44	2	194	210	1	407	654
% App. Total																					
PHF	.000	.000	.000	.000	.000	.833	.896	.750	.000	.890	.750	.500	.462	.000	.579	.500	.770	.833	.250	.942	.929

