



MINNESOTA DEPT OF TRANSPORTATION

TRAFFIC DATA COLLECTION - METRO

Th-61 at 4th St., HASTINGS
 Ref.Pt.: 117.337
 JAMAR #T-2582 DS/RE
 TURN MOVEMENT COUNT

File Name : TH-61 at 4th St HASTINGS 2008
 Site Code : 00000000
 Start Date : 4/30/2008
 Page No : 1

Groups Printed- Cars & Trucks

Start Time	TH-61 Southbound				4th St E Westbound				TH-61 Northbound				4th St W Eastbound				Int. Total
	Left	Thru	Right	Peds	Left	Thru	Right	Peds	Left	Thru	Right	Peds	Left	Thru	Right	Peds	
06:00	0	126	1	0	4	2	3	1	2	176	2	0	11	0	1	0	329
06:15	1	167	5	0	9	1	2	0	0	211	0	0	8	0	4	0	408
06:30	3	191	8	0	8	1	2	0	1	208	3	0	19	2	3	0	449
06:45	3	158	16	0	3	1	2	0	2	187	1	0	12	2	0	0	387
Total	7	642	30	0	24	5	9	1	5	782	6	0	50	4	8	0	1573
07:00	2	162	13	1	4	1	4	0	2	219	1	1	31	3	9	0	453
07:15	4	187	17	0	4	9	0	0	2	214	9	0	25	7	2	1	481
07:30	7	205	23	0	7	3	5	0	1	221	4	0	24	2	2	0	504
07:45	12	167	23	0	11	2	3	0	3	197	14	0	19	6	10	1	468
Total	25	721	76	1	26	15	12	0	8	851	28	1	99	18	23	2	1906
08:00	6	184	15	0	6	0	4	0	3	164	5	0	12	3	7	0	409
08:15	7	169	12	1	6	3	2	0	6	165	9	1	18	5	2	4	410
08:30	2	160	10	0	17	8	3	0	9	158	10	0	14	6	11	0	408
08:45	2	152	13	0	14	10	2	1	6	128	6	0	14	6	8	0	362
Total	17	665	50	1	43	21	11	1	24	615	30	1	58	20	28	4	1589
*** BREAK ***																	
15:00	4	199	15	0	16	14	12	0	2	213	15	0	13	9	12	0	524
15:15	5	211	15	0	22	10	8	0	2	202	15	0	19	4	11	0	524
15:30	7	227	16	0	26	9	10	0	4	234	15	0	24	5	13	0	590
15:45	7	242	27	0	28	6	1	0	2	222	7	0	25	8	9	0	584
Total	23	879	73	0	92	39	31	0	10	871	52	0	81	26	45	0	2222
16:00	7	228	13	0	20	11	1	0	5	215	11	0	27	10	13	0	561
16:15	1	228	14	0	14	8	8	0	7	239	8	0	31	3	8	0	569
16:30	3	257	16	0	12	9	7	0	5	243	13	0	38	5	11	0	619
16:45	5	231	17	0	18	7	6	0	4	232	9	0	33	6	15	0	583
Total	16	944	60	0	64	35	22	0	21	929	41	0	129	24	47	0	2332
17:00	3	247	21	0	17	8	5	0	5	215	5	0	27	4	13	0	570
17:15	5	223	20	0	9	2	6	0	4	249	15	0	20	4	8	0	565
17:30	2	223	21	0	13	2	4	0	3	207	8	0	22	7	8	0	520
17:45	3	214	14	0	17	1	2	0	7	243	10	0	22	7	14	0	554
Total	13	907	76	0	56	13	17	0	19	914	38	0	91	22	43	0	2209
Grand Total	101	4758	365	2	305	128	102	2	87	4962	195	2	508	114	194	6	11831
Apprch %	1.9	91	7	0	56.8	23.8	19	0.4	1.7	94.6	3.7	0	61.8	13.9	23.6	0.7	
Total %	0.9	40.2	3.1	0	2.6	1.1	0.9	0	0.7	41.9	1.6	0	4.3	1	1.6	0.1	



MINNESOTA DEPT OF TRANSPORTATION

TRAFFIC DATA COLLECTION - METRO

Th-61 at 4th St., HASTINGS
 Ref.Pt.: 117.337
 JAMAR #T-2582 DS/RE
 TURN MOVEMENT COUNT

File Name : TH-61 at 4th St HASTINGS 2008
 Site Code : 00000000
 Start Date : 4/30/2008
 Page No : 2

Start Time	TH-61 Southbound					4th St E Westbound					TH-61 Northbound					4th St W Eastbound					Int. Total
	Left	Thru	Right	Peds	App. Total	Left	Thru	Right	Peds	App. Total	Left	Thru	Right	Peds	App. Total	Left	Thru	Right	Peds	App. Total	
Peak Hour Analysis From 06:00 to 08:45 - Peak 1 of 1																					
Peak Hour for Entire Intersection Begins at 07:00																					
07:00	2	162	13	1	178	4	1	4	0	9	2	219	1	1	223	31	3	9	0	43	453
07:15	4	187	17	0	208	4	9	0	0	13	2	214	9	0	225	25	7	2	1	35	481
07:30	7	205	23	0	235	7	3	5	0	15	1	221	4	0	226	24	2	2	0	28	504
07:45	12	167	23	0	202	11	2	3	0	16	3	197	14	0	214	19	6	10	1	36	468
Total Volume	25	721	76	1	823	26	15	12	0	53	8	851	28	1	888	99	18	23	2	142	1906
% App. Total																					
PHF	.521	.879	.826	.250	.876	.591	.417	.600	.000	.828	.667	.963	.500	.250	.982	.798	.643	.575	.500	.826	.945

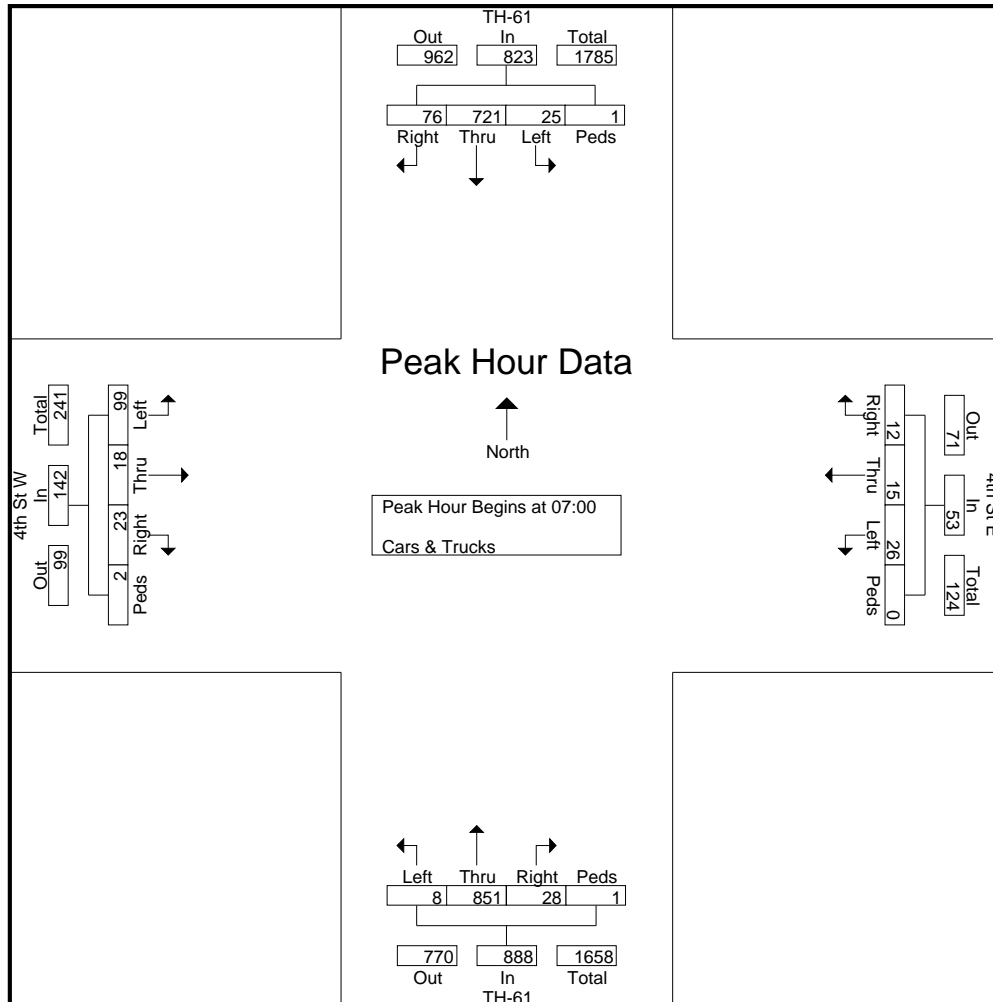



MINNESOTA DEPT OF TRANSPORTATION

TRAFFIC DATA COLLECTION - METRO

Th-61 at 4th St., HASTINGS
 Ref.Pt.: 117.337
 JAMAR #T-2582 DS/RE
 TURN MOVEMENT COUNT

File Name : TH-61 at 4th St HASTINGS 2008
 Site Code : 00000000
 Start Date : 4/30/2008
 Page No : 3

Start Time	TH-61 Southbound					4th St E Westbound					TH-61 Northbound					4th St W Eastbound					Int. Total
	Left	Thru	Right	Peds	App. Total	Left	Thru	Right	Peds	App. Total	Left	Thru	Right	Peds	App. Total	Left	Thru	Right	Peds	App. Total	
Peak Hour Analysis From 15:00 to 17:45 - Peak 1 of 1																					
Peak Hour for Entire Intersection Begins at 16:15																					
16:15	1	228	14	0	243	14	8	8	0	30	7	239	8	0	254	31	3	8	0	42	569
16:30	3	257	16	0	276	12	9	7	0	28	5	243	13	0	261	38	5	11	0	54	619
16:45	5	231	17	0	253	18	7	6	0	31	4	232	9	0	245	33	6	15	0	54	583
17:00	3	247	21	0	271	17	8	5	0	30	5	215	5	0	225	27	4	13	0	44	570
Total Volume	12	963	68	0	1043	61	32	26	0	119	21	929	35	0	985	129	18	47	0	194	2341
% App. Total																					
PHF	.600	.937	.810	.000	.945	.847	.889	.813	.000	.960	.750	.956	.673	.000	.943	.849	.750	.783	.000	.898	.945

