

Alliant Engineering Inc Minneapolis, MN 55415

TH-55 at Niagara Lane / Plymouth Blvd
 Ref.Pt.: 179.737
 Alliant Engineering Inc
 TURN MOVEMENT COUNT

File Name : 43_TH 55 at Niagara Ln_012511
 Site Code : 00000043
 Start Date : 1/25/2011
 Page No : 1

Groups Printed- Unshifted - Bank 1

Start Time	Plymouth Blvd Southbound				TH-55 Westbound				Niagara Lane Northbound				TH-55 Eastbound				Int. Total
	Left	Thru	Rght	Peds	Left	Thru	Rght	Peds	Left	Thru	Rght	Other	Left	Thru	Rght	Peds	
06:00	14	5	3	0	16	64	15	0	1	6	9	0	3	225	13	0	374
06:15	25	9	0	0	35	97	13	0	0	1	6	0	2	344	22	0	554
06:30	29	10	2	0	22	161	9	0	1	2	11	0	1	491	23	0	762
06:45	29	16	1	0	55	192	17	0	4	7	12	0	5	518	35	0	891
Total	97	40	6	0	128	514	54	0	6	16	38	0	11	1578	93	0	2581
07:00	44	14	4	0	33	198	14	0	6	6	8	0	8	551	29	0	915
07:15	41	20	5	0	29	149	13	0	0	3	11	0	1	581	30	0	883
07:30	50	26	3	0	42	158	15	0	3	9	12	0	4	561	32	0	915
07:45	42	26	7	0	42	209	22	0	3	7	16	0	4	591	39	0	1008
Total	177	86	19	0	146	714	64	0	12	25	47	0	17	2284	130	0	3721
08:00	33	14	4	0	30	153	23	0	1	5	15	0	7	531	45	0	861
08:15	30	9	2	0	25	166	15	1	0	6	15	0	7	438	24	0	738
08:30	40	7	2	0	20	197	16	0	1	5	13	0	8	377	18	0	704
08:45	47	18	5	0	22	175	19	0	3	20	8	0	16	339	14	0	686
Total	150	48	13	0	97	691	73	1	5	36	51	0	38	1685	101	0	2989
09:00	28	15	6	0	18	163	26	0	3	14	12	0	9	251	12	0	557
09:15	27	12	2	0	24	141	28	0	5	7	11	0	9	251	8	0	525
*** BREAK ***																	
Total	55	27	8	0	42	304	54	0	8	21	23	0	18	502	20	0	1082
*** BREAK ***																	
10:30	21	7	2	0	5	176	15	0	4	10	14	0	5	175	2	0	436
10:45	48	12	4	0	13	204	15	0	5	15	10	0	7	163	3	0	499
Total	69	19	6	0	18	380	30	0	9	25	24	0	12	338	5	0	935
11:00	56	14	3	0	16	188	28	0	19	21	31	0	6	186	10	0	578
11:15	55	22	2	0	15	197	29	0	21	12	21	0	13	221	9	0	617
11:30	79	21	4	0	17	245	39	0	17	34	27	0	15	224	10	0	732
11:45	50	19	8	0	30	233	47	0	20	29	20	0	26	203	19	0	704
Total	240	76	17	0	78	863	143	0	77	96	99	0	60	834	48	0	2631
12:00	65	27	7	0	25	250	36	0	25	33	21	0	21	186	15	0	711
12:15	45	21	7	0	19	243	27	0	22	17	19	0	23	242	19	0	704
12:30	61	33	6	0	19	238	26	0	19	22	18	0	19	273	13	0	747
12:45	57	29	5	0	25	243	14	0	8	14	17	0	6	239	19	0	676
Total	228	110	25	0	88	974	103	0	74	86	75	0	69	940	66	0	2838
*** BREAK ***																	
14:30	55	14	6	0	17	319	28	1	18	26	47	0	24	211	13	2	781
14:45	50	17	11	0	26	323	23	0	16	8	24	0	16	232	8	0	754
Total	105	31	17	0	43	642	51	1	34	34	71	0	40	443	21	2	1535
15:00	47	17	13	0	16	314	40	0	37	17	43	0	11	268	7	0	830
15:15	43	15	11	0	23	367	52	0	27	21	27	0	12	197	6	1	802
15:30	57	21	17	0	16	348	53	0	69	38	81	0	10	225	5	0	940
15:45	41	19	12	0	14	428	37	0	29	27	38	0	24	185	4	0	858
Total	188	72	53	0	69	1457	182	0	162	103	189	0	57	875	22	1	3430
16:00	47	14	14	0	20	429	57	0	62	43	38	0	15	252	5	0	996
16:15	48	15	11	0	15	482	60	0	44	25	39	0	14	233	4	0	990
16:30	65	21	14	0	10	396	60	0	85	50	69	0	16	270	3	0	1059
16:45	61	17	13	0	10	483	62	0	54	46	29	0	18	217	6	0	1016
Total	221	67	52	0	55	1790	239	0	245	164	175	0	63	972	18	0	4061

Alliant Engineering Inc Minneapolis, MN 55415

TH-55 at Niagara Lane / Plymouth Blvd
 Ref.Pt.: 179.737
 Alliant Engineering Inc
 TURN MOVEMENT COUNT

File Name : 43_TH 55 at Niagara Ln_012511
 Site Code : 00000043
 Start Date : 1/25/2011
 Page No : 2

Groups Printed- Unshifted - Bank 1

Start Time	Plymouth Blvd Southbound				TH-55 Westbound				Niagara Lane Northbound				TH-55 Eastbound				Int. Total
	Left	Thru	Rght	Peds	Left	Thru	Rght	Peds	Left	Thru	Rght	Other	Left	Thru	Rght	Peds	
17:00	86	12	10	0	11	458	75	0	89	46	40	0	12	274	6	0	1119
17:15	64	19	17	0	6	494	77	0	49	44	37	0	16	240	6	0	1069
17:30	68	11	10	0	9	487	55	0	25	43	29	0	23	242	7	0	1009
17:45	45	20	18	0	5	504	60	0	15	28	19	0	23	216	6	0	959
Total	263	62	55	0	31	1943	267	0	178	161	125	0	74	972	25	0	4156
Grand Total	1793	638	271	0	795	10272	1260	2	810	767	917	0	459	11423	549	3	29959
Apprch %	66.4	23.6	10	0	6.4	83.3	10.2	0	32.5	30.8	36.8	0	3.7	91.9	4.4	0	
Total %	6	2.1	0.9	0	2.7	34.3	4.2	0	2.7	2.6	3.1	0	1.5	38.1	1.8	0	
Unshifted	1768	622	262	0	739	9983	1228	2	792	758	859	0	448	11186	530	3	29180
% Unshifted	98.6	97.5	96.7	0	93	97.2	97.5	100	97.8	98.8	93.7	0	97.6	97.9	96.5	100	97.4
Bank 1	25	16	9	0	56	289	32	0	18	9	58	0	11	237	19	0	779
% Bank 1	1.4	2.5	3.3	0	7	2.8	2.5	0	2.2	1.2	6.3	0	2.4	2.1	3.5	0	2.6

Alliant Engineering Inc Minneapolis, MN 55415

TH-55 at Niagara Lane / Plymouth Blvd
 Ref.Pt.: 179.737
 Alliant Engineering Inc
 TURN MOVEMENT COUNT

File Name : 43_TH 55 at Niagara Ln_012511
 Site Code : 00000043
 Start Date : 1/25/2011
 Page No : 3

Start Time	Plymouth Blvd Southbound					TH-55 Westbound					Niagara Lane Northbound					TH-55 Eastbound					Int. Total
	Left	Thru	Rght	Peds	App. Total	Left	Thru	Rght	Peds	App. Total	Left	Thru	Rght	Other	App. Total	Left	Thru	Rght	Peds	App. Total	
Peak Hour Analysis From 06:00 to 09:15 - Peak 1 of 1																					
Peak Hour for Entire Intersection Begins at 07:00																					
07:00	44	14	4	0	62	33	198	14	0	245	6	6	8	0	20	8	551	29	0	588	915
07:15	41	20	5	0	66	29	149	13	0	191	0	3	11	0	14	1	581	30	0	612	883
07:30	50	26	3	0	79	42	158	15	0	215	3	9	12	0	24	4	561	32	0	597	915
07:45	42	26	7	0	75	42	209	22	0	273	3	7	16	0	26	4	591	39	0	634	1008
Total Volume	177	86	19	0	282	146	714	64	0	924	12	25	47	0	84	17	2284	130	0	2431	3721
% App. Total	62.8	30.5	6.7	0		15.8	77.3	6.9	0		14.3	29.8	56	0		0.7	94	5.3	0		
PHF	.885	.827	.679	.000	.892	.869	.854	.727	.000	.846	.500	.694	.734	.000	.808	.531	.966	.833	.000	.959	.923

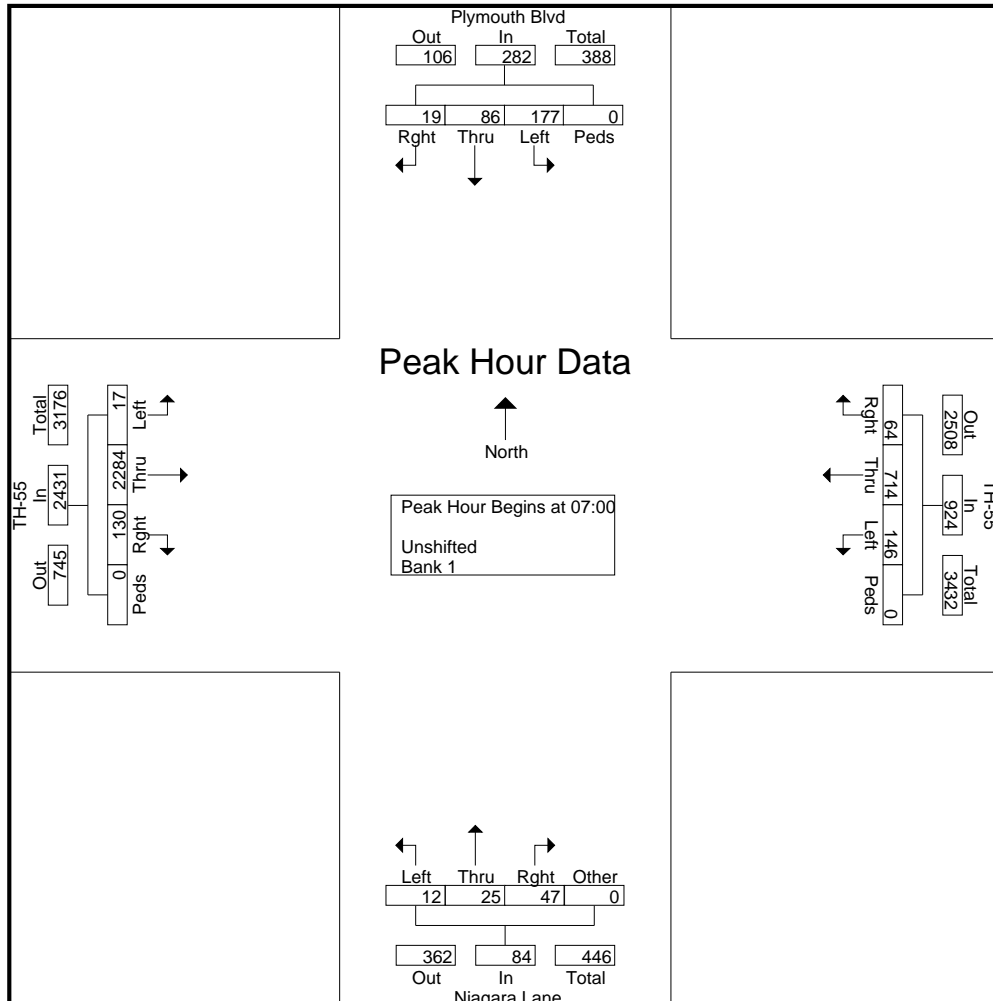

Alliant Engineering Inc Minneapolis, MN 55415

TH-55 at Niagara Lane / Plymouth Blvd
 Ref.Pt.: 179.737
 Alliant Engineering Inc
 TURN MOVEMENT COUNT

File Name : 43_TH 55 at Niagara Ln_012511
 Site Code : 00000043
 Start Date : 1/25/2011
 Page No : 4

Start Time	Plymouth Blvd Southbound					TH-55 Westbound					Niagara Lane Northbound					TH-55 Eastbound					Int. Total
	Left	Thru	Rght	Peds	App. Total	Left	Thru	Rght	Peds	App. Total	Left	Thru	Rght	Other	App. Total	Left	Thru	Rght	Peds	App. Total	
Peak Hour Analysis From 14:30 to 17:45 - Peak 1 of 1																					
Peak Hour for Entire Intersection Begins at 16:30																					
16:30	65	21	14	0	100	10	396	60	0	466	85	50	69	0	204	16	270	3	0	289	1059
16:45	61	17	13	0	91	10	483	62	0	555	54	46	29	0	129	18	217	6	0	241	1016
17:00	86	12	10	0	108	11	458	75	0	544	89	46	40	0	175	12	274	6	0	292	1119
17:15	64	19	17	0	100	6	494	77	0	577	49	44	37	0	130	16	240	6	0	262	1069
Total Volume	276	69	54	0	399	37	1831	274	0	2142	277	186	175	0	638	62	1001	21	0	1084	4263
% App. Total	69.2	17.3	13.5	0		1.7	85.5	12.8	0		43.4	29.2	27.4	0		5.7	92.3	1.9	0		
PHF	.802	.821	.794	.000	.924	.841	.927	.890	.000	.928	.778	.930	.634	.000	.782	.861	.913	.875	.000	.928	.952

