



MINNESOTA DEPT OF TRANSPORTATION

TRAFFIC DATA COLLECTION - METRO

: TH-55 AT CSAH-20 MAIN ST ROCKFORD
 Ref.Pt.: 165+00.336
 JAMAR# 634 DR
 TURN MOVEMENT COUNT

File Name : TH 55 AT CSAH 20 MAIN ST 2007
 Site Code : 00000000
 Start Date : 10/2/2007
 Page No : 1

Groups Printed- Unshifted

Start Time	CSAH 20 MAIN ST Southbound				TH 55 Westbound				CSAH 20 MAIN ST Northbound				TH 55 Eastbound				Int. Total
	Left	Thru	Right	Peds	Left	Thru	Right	Peds	Left	Thru	Right	Peds	Left	Thru	Right	Peds	
06:00	15	1	5	0	5	26	4	0	1	3	18	0	20	278	0	0	376
06:15	44	1	9	0	3	24	10	0	3	5	22	0	17	349	0	0	487
06:30	29	1	7	0	3	37	9	0	5	11	26	0	30	324	3	0	485
06:45	43	3	9	0	1	63	7	0	5	12	30	0	30	262	0	0	465
Total	131	6	30	0	12	150	30	0	14	31	96	0	97	1213	3	0	1813
07:00	65	2	13	0	6	49	16	0	2	15	42	0	28	310	0	0	548
07:15	46	2	11	0	9	76	18	0	5	16	26	0	37	367	0	0	613
07:30	53	4	11	0	5	66	11	0	6	18	36	0	40	292	0	0	542
07:45	59	18	15	0	4	91	11	0	5	21	22	0	24	277	0	0	547
Total	223	26	50	0	24	282	56	0	18	70	126	0	129	1246	0	0	2250
08:00	45	4	20	0	9	55	17	0	6	15	15	0	28	204	0	0	418
08:15	39	3	9	0	4	53	15	0	1	2	20	0	17	152	0	0	315
08:30	40	2	11	0	6	55	13	0	4	3	13	0	14	180	2	0	343
08:45	30	4	8	0	4	66	6	0	2	12	6	0	16	132	1	0	287
Total	154	13	48	0	23	229	51	0	13	32	54	0	75	668	3	0	1363
*** BREAK ***																	
15:00	22	12	22	0	24	162	36	0	6	7	8	0	15	96	4	0	414
15:15	26	12	25	0	21	221	31	0	7	12	8	0	18	79	1	0	461
15:30	14	11	19	0	27	274	48	0	7	8	3	0	13	101	1	0	526
15:45	21	19	28	0	39	282	43	0	6	6	10	0	20	78	1	0	553
Total	83	54	94	0	111	939	158	0	26	33	29	0	66	354	7	0	1954
16:00	17	6	12	0	17	278	55	0	3	8	4	0	26	110	0	0	536
16:15	22	10	32	0	26	295	38	0	4	4	8	0	21	79	5	0	544
16:30	27	18	30	0	43	301	52	0	5	10	20	0	22	115	2	0	645
16:45	34	19	40	0	44	300	52	0	8	9	8	0	16	82	3	0	615
Total	100	53	114	0	130	1174	197	0	20	31	40	0	85	386	10	0	2340
17:00	20	12	24	0	43	277	47	0	11	4	7	0	11	89	2	0	547
17:15	26	14	38	0	41	293	53	0	8	9	7	0	12	96	1	0	598
17:30	18	13	24	0	43	309	57	0	10	6	6	0	17	72	0	0	575
17:45	28	8	20	0	42	242	40	0	4	10	7	0	18	74	0	0	493
Total	92	47	106	0	169	1121	197	0	33	29	27	0	58	331	3	0	2213
Grand Total	783	199	442	0	469	3895	689	0	124	226	372	0	510	4198	26	0	11933
Apprch %	55	14	31	0	9.3	77.1	13.6	0	17.2	31.3	51.5	0	10.8	88.7	0.5	0	
Total %	6.6	1.7	3.7	0	3.9	32.6	5.8	0	1	1.9	3.1	0	4.3	35.2	0.2	0	



MINNESOTA DEPT OF TRANSPORTATION

TRAFFIC DATA COLLECTION - METRO

: TH-55 AT CSAH-20 MAIN ST ROCKFORD
 Ref.Pt.: 165+00.336
 JAMAR# 634 DR
 TURN MOVEMENT COUNT

File Name : TH 55 AT CSAH 20 MAIN ST 2007
 Site Code : 00000000
 Start Date : 10/2/2007
 Page No : 2

Start Time	CSAH 20 MAIN ST Southbound					TH 55 Westbound					CSAH 20 MAIN ST Northbound					TH 55 Eastbound					Int. Total
	Left	Thru	Right	Peds	App. Total	Left	Thru	Right	Peds	App. Total	Left	Thru	Right	Peds	App. Total	Left	Thru	Right	Peds	App. Total	
Peak Hour Analysis From 06:00 to 08:45 - Peak 1 of 1																					
Peak Hour for Entire Intersection Begins at 07:00																					
07:00	65	2	13	0	80	6	49	16	0	71	2	15	42	0	59	28	310	0	0	338	548
07:15	46	2	11	0	59	9	76	18	0	103	5	16	26	0	47	37	367	0	0	404	613
07:30	53	4	11	0	68	5	66	11	0	82	6	18	36	0	60	40	292	0	0	332	542
07:45	59	18	15	0	92	4	91	11	0	106	5	21	22	0	48	24	277	0	0	301	547
Total Volume	223	26	50	0	299	24	282	56	0	362	18	70	126	0	214	129	1246	0	0	1375	2250
% App. Total	74.6	8.7	16.7	0		6.6	77.9	15.5	0		8.4	32.7	58.9	0		9.4	90.6	0	0		
PHF	.858	.361	.833	.000	.813	.667	.775	.778	.000	.854	.750	.833	.750	.000	.892	.806	.849	.000	.000	.851	.918

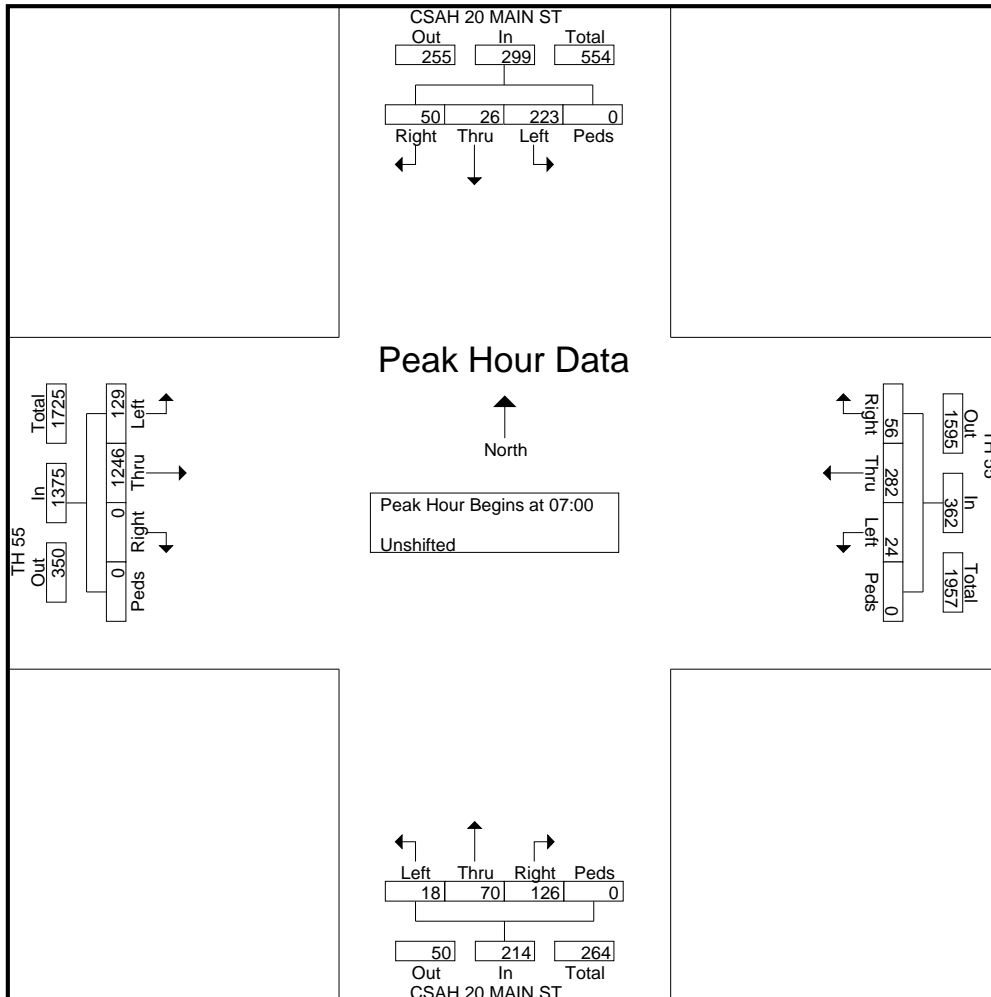



MINNESOTA DEPT OF TRANSPORTATION

TRAFFIC DATA COLLECTION - METRO

: TH-55 AT CSAH-20 MAIN ST ROCKFORD
 Ref.Pt.: 165+00.336
 JAMAR# 634 DR
 TURN MOVEMENT COUNT

File Name : TH 55 AT CSAH 20 MAIN ST 2007
 Site Code : 00000000
 Start Date : 10/2/2007
 Page No : 3

Start Time	CSAH 20 MAIN ST Southbound					TH 55 Westbound					CSAH 20 MAIN ST Northbound					TH 55 Eastbound					Int. Total
	Left	Thru	Right	Peds	App. Total	Left	Thru	Right	Peds	App. Total	Left	Thru	Right	Peds	App. Total	Left	Thru	Right	Peds	App. Total	
Peak Hour Analysis From 15:00 to 17:45 - Peak 1 of 1																					
Peak Hour for Entire Intersection Begins at 16:30																					
16:30	27	18	30	0	75	43	301	52	0	396	5	10	20	0	35	22	115	2	0	139	645
16:45	34	19	40	0	93	44	300	52	0	396	8	9	8	0	25	16	82	3	0	101	615
17:00	20	12	24	0	56	43	277	47	0	367	11	4	7	0	22	11	89	2	0	102	547
17:15	26	14	38	0	78	41	293	53	0	387	8	9	7	0	24	12	96	1	0	109	598
Total Volume	107	63	132	0	302	171	1171	204	0	1546	32	32	42	0	106	61	382	8	0	451	2405
% App. Total	35.4	20.9	43.7	0		11.1	75.7	13.2	0		30.2	30.2	39.6	0		13.5	84.7	1.8	0		
PHF	.787	.829	.825	.000	.812	.972	.973	.962	.000	.976	.727	.800	.525	.000	.757	.693	.830	.667	.000	.811	.932

