



MINNESOTA DEPT OF TRANSPORTATION

TRAFFIC DATA COLLECTION - METRO

TH-52 at 190th St / Co.Rd.62
 Ref.Pt.: 110.845
 JAMAR # T-2638 CAH
 TURN MOVEMENT COUNT

File Name : TH-52 at 190th St CoRd-62 2011
 Site Code : 00000000
 Start Date : 2/16/2011
 Page No : 1

Groups Printed- Cars & Trucks

Start Time	TH-52 Southbound				190th St E / Co.Rd.62 Westbound				TH-52 Northbound				190th St E / Co.Rd.62 Eastbound				Int. Total	
	Left	Thru	Right	Peds	Left	Thru	Right	Peds	Left	Thru	Right	Peds	Left	Thru	Right	Peds		
06:00	6	106	0	0	1	0	21	0	0	225	0	0	0	0	0	0	0	359
06:15	3	104	0	0	0	0	23	0	0	276	1	0	0	0	0	0	0	407
06:30	2	118	0	0	0	0	33	0	1	319	0	0	2	0	0	0	0	475
06:45	4	130	0	0	0	0	19	0	0	266	0	0	0	0	1	0	0	420
Total	15	458	0	0	1	0	96	0	1	1086	1	0	2	0	1	0	0	1661
07:00	4	155	0	0	1	0	17	0	0	264	0	0	1	1	1	0	0	444
07:15	2	151	0	0	1	0	17	0	0	333	0	0	0	0	0	0	0	504
07:30	8	165	0	0	0	0	22	0	0	291	0	0	0	1	1	0	0	488
07:45	11	139	0	0	2	0	15	0	0	276	0	0	0	0	0	0	0	443
Total	25	610	0	0	4	0	71	0	0	1164	0	0	1	2	2	0	0	1879
08:00	6	140	0	0	1	0	21	0	0	258	0	0	1	0	0	0	0	427
08:15	7	162	0	0	0	0	6	0	0	254	1	0	0	1	1	0	0	432
08:30	4	155	1	0	0	0	20	0	2	198	0	0	0	0	0	0	0	380
08:45	2	155	0	0	1	1	15	0	0	224	0	0	0	0	0	0	0	398
Total	19	612	1	0	2	1	62	0	2	934	1	0	1	1	1	0	0	1637
*** BREAK ***																		
15:00	16	209	2	0	0	2	10	0	0	169	1	0	1	0	1	0	0	411
15:15	13	157	0	0	0	0	6	0	0	168	0	0	0	0	0	0	0	344
15:30	21	257	1	0	1	1	7	0	0	156	1	0	0	0	1	0	0	446
15:45	18	313	1	0	0	0	6	0	0	210	0	0	0	1	0	0	0	549
Total	68	936	4	0	1	3	29	0	0	703	2	0	1	1	2	0	0	1750
16:00	23	291	1	0	2	0	9	0	2	205	0	0	0	0	2	0	0	535
16:15	29	290	0	0	0	1	9	0	0	190	0	0	0	0	0	0	0	519
16:30	34	306	1	0	0	1	9	0	1	195	0	0	0	0	0	0	0	547
16:45	22	329	1	0	1	2	7	0	2	213	0	0	0	2	1	0	0	580
Total	108	1216	3	0	3	4	34	0	5	803	0	0	0	2	3	0	0	2181
17:00	19	323	2	0	0	0	9	1	0	200	2	0	0	1	0	0	0	557
17:15	21	318	0	0	1	0	11	0	0	212	3	0	1	1	0	0	0	568
17:30	30	318	0	0	0	0	22	0	0	164	2	0	0	0	1	0	0	537
17:45	26	261	1	0	0	0	11	0	0	190	0	0	1	0	1	0	0	491
Total	96	1220	3	0	1	0	53	1	0	766	7	0	2	2	2	0	0	2153
Grand Total	331	5052	11	0	12	8	345	1	8	5456	11	0	7	8	11	0	0	11261
Apprch %	6.1	93.7	0.2	0	3.3	2.2	94.3	0.3	0.1	99.7	0.2	0	26.9	30.8	42.3	0	0	
Total %	2.9	44.9	0.1	0	0.1	0.1	3.1	0	0.1	48.5	0.1	0	0.1	0.1	0.1	0	0	



MINNESOTA DEPT OF TRANSPORTATION

TRAFFIC DATA COLLECTION - METRO

TH-52 at 190th St / Co.Rd.62
 Ref.Pt.: 110.845
 JAMAR # T-2638 CAH
 TURN MOVEMENT COUNT

File Name : TH-52 at 190th St CoRd-62 2011
 Site Code : 00000000
 Start Date : 2/16/2011
 Page No : 2

Start Time	TH-52 Southbound					190th St E / Co.Rd.62 Westbound					TH-52 Northbound					190th St E / Co.Rd.62 Eastbound					Int. Total
	Left	Thru	Right	Peds	App. Total	Left	Thru	Right	Peds	App. Total	Left	Thru	Right	Peds	App. Total	Left	Thru	Right	Peds	App. Total	
Peak Hour Analysis From 06:00 to 08:45 - Peak 1 of 1																					
Peak Hour for Entire Intersection Begins at 07:00																					
07:00	4	155	0	0	159	1	0	17	0	18	0	264	0	0	264	1	1	1	0	3	444
07:15	2	151	0	0	153	1	0	17	0	18	0	333	0	0	333	0	0	0	0	0	504
07:30	8	165	0	0	173	0	0	22	0	22	0	291	0	0	291	0	1	1	0	2	488
07:45	11	139	0	0	150	2	0	15	0	17	0	276	0	0	276	0	0	0	0	0	443
Total Volume	25	610	0	0	635	4	0	71	0	75	0	1164	0	0	1164	1	2	2	0	5	1879
% App. Total	3.9	96.1	0	0		5.3	0	94.7	0		0	100	0	0		20	40	40	0		
PHF	.568	.924	.000	.000	.918	.500	.000	.807	.000	.852	.000	.874	.000	.000	.874	.250	.500	.500	.000	.417	.932

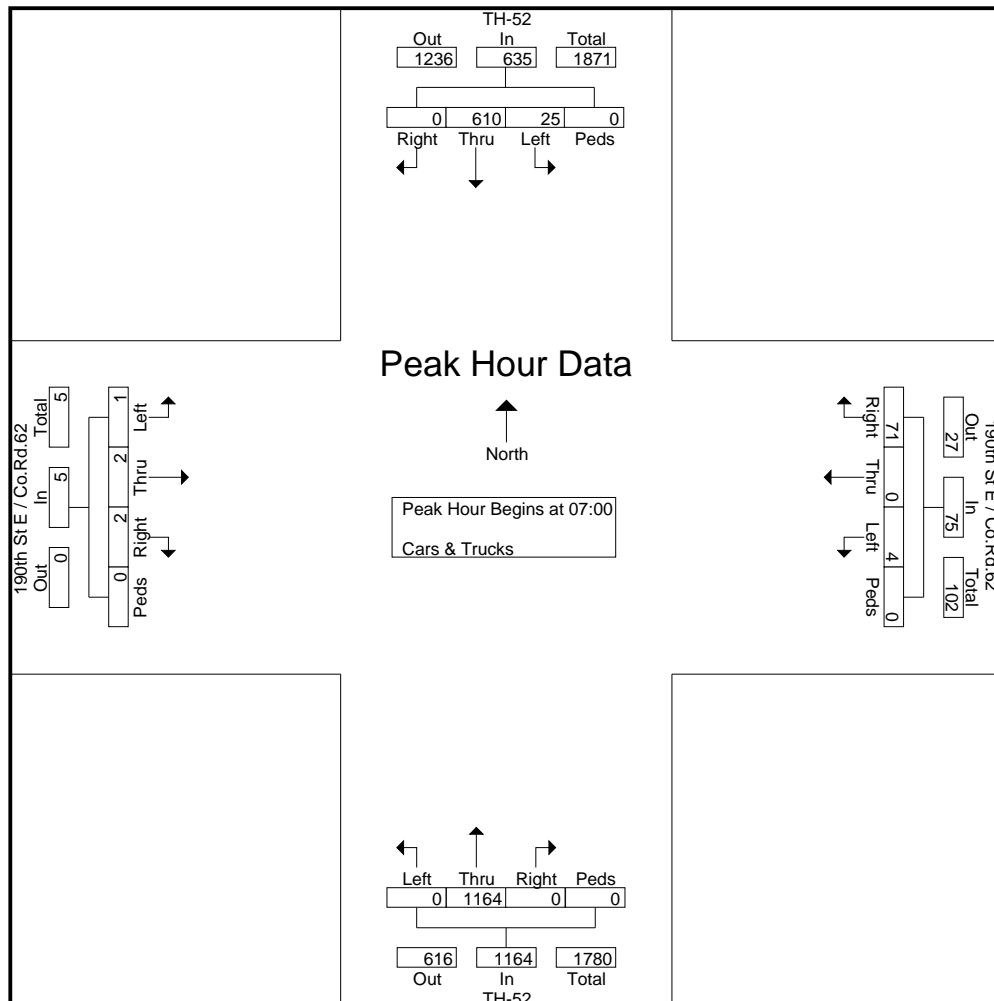



MINNESOTA DEPT OF TRANSPORTATION

TRAFFIC DATA COLLECTION - METRO

TH-52 at 190th St / Co.Rd.62
 Ref.Pt.: 110.845
 JAMAR # T-2638 CAH
 TURN MOVEMENT COUNT

File Name : TH-52 at 190th St CoRd-62 2011
 Site Code : 00000000
 Start Date : 2/16/2011
 Page No : 3

Start Time	TH-52 Southbound					190th St E / Co.Rd.62 Westbound					TH-52 Northbound					190th St E / Co.Rd.62 Eastbound					Int. Total
	Left	Thru	Right	Peds	App. Total	Left	Thru	Right	Peds	App. Total	Left	Thru	Right	Peds	App. Total	Left	Thru	Right	Peds	App. Total	
16:30	34	306	1	0	341	0	1	9	0	10	1	195	0	0	196	0	0	0	0	0	547
16:45	22	329	1	0	352	1	2	7	0	10	2	213	0	0	215	0	2	1	0	3	580
17:00	19	323	2	0	344	0	0	9	1	10	0	200	2	0	202	0	1	0	0	1	557
17:15	21	318	0	0	339	1	0	11	0	12	0	212	3	0	215	1	1	0	0	2	568
Total Volume	96	1276	4	0	1376	2	3	36	1	42	3	820	5	0	828	1	4	1	0	6	2252
% App. Total	7	92.7	0.3	0		4.8	7.1	85.7	2.4		0.4	99	0.6	0		16.7	66.7	16.7	0		
PHF	.706	.970	.500	.000	.977	.500	.375	.818	.250	.875	.375	.962	.417	.000	.963	.250	.500	.250	.000	.500	.971

Peak Hour Analysis From 15:00 to 17:45 - Peak 1 of 1
 Peak Hour for Entire Intersection Begins at 16:30

