



MINNESOTA DEPT OF TRANSPORTATION

TRAFFIC DATA COLLECTION - METRO

TH-52 at 200th St / CSAH-66
 Ref.Pt; 109.822
 Jamar # T-2638 CAH
 TURN MOVEMENT COUNT

File Name : TH 52 at 200th ST CSAH 66
 Site Code : 109.822
 Start Date : 5/17/2011
 Page No : 1

Groups Printed- Unshifted - Bank 1

Start Time	TH-52 Southbound				200th St / CSAH 66 Westbound				TH-52 Northbound				200th St / CSAH 66 Eastbound				Int. Total
	Left	Thru	Right	Peds	Left	Thru	Right	Peds	Left	Thru	Right	Peds	Left	Thru	Right	Peds	
06:00	0	101	4	0	0	3	3	0	2	257	0	0	13	4	4	0	391
06:15	0	125	8	0	0	10	0	0	0	285	0	0	18	2	5	0	453
06:30	1	123	13	0	1	13	6	0	1	289	2	0	15	1	1	0	466
06:45	0	155	6	0	2	11	3	0	2	302	1	0	9	4	1	0	496
Total	1	504	31	0	3	37	12	0	5	1133	3	0	55	11	11	0	1806
07:00	0	168	9	0	2	7	3	0	1	299	4	0	19	5	4	0	521
07:15	0	179	8	0	0	2	0	0	2	326	3	0	18	3	3	0	544
07:30	1	161	8	0	2	6	0	0	4	304	1	0	20	11	4	0	522
07:45	1	168	7	0	1	7	1	0	0	241	3	0	20	4	8	0	461
Total	2	676	32	0	5	22	4	0	7	1170	11	0	77	23	19	0	2048
08:00	4	154	5	0	0	7	0	0	2	236	0	0	11	4	2	0	425
08:15	1	143	5	0	1	6	1	0	2	182	1	0	10	6	3	0	361
08:30	2	152	8	0	0	3	2	0	3	183	1	0	9	5	5	0	373
08:45	2	155	8	0	0	5	1	0	0	193	0	0	7	5	3	0	379
Total	9	604	26	0	1	21	4	0	7	794	2	0	37	20	13	0	1538
*** BREAK ***																	
15:00	0	211	13	0	2	5	0	0	3	177	2	0	4	4	3	0	424
15:15	1	203	23	0	0	10	0	0	0	188	1	0	0	3	2	0	431
15:30	2	265	11	0	1	6	0	0	1	201	1	0	2	13	2	0	505
15:45	3	284	14	0	1	5	0	0	5	182	4	0	2	14	1	0	515
Total	6	963	61	0	4	26	0	0	9	748	8	0	8	34	8	0	1875
16:00	1	246	13	0	1	6	2	0	7	181	6	0	2	5	3	0	473
16:15	1	296	18	0	1	3	1	0	3	199	3	0	8	17	0	0	550
16:30	2	269	17	0	0	3	0	0	2	217	2	0	5	9	4	0	530
16:45	0	274	25	0	1	7	1	0	2	209	0	0	6	6	2	0	533
Total	4	1085	73	0	3	19	4	0	14	806	11	0	21	37	9	0	2086
17:00	5	301	14	0	4	9	1	0	3	181	3	0	7	9	1	0	538
17:15	1	310	25	0	2	8	2	0	5	228	1	0	6	12	3	0	603
17:30	5	327	25	0	2	9	0	0	5	211	3	0	6	8	3	0	604
17:45	1	229	22	0	2	9	3	0	6	187	3	0	8	13	4	0	487
Total	12	1167	86	0	10	35	6	0	19	807	10	0	27	42	11	0	2232
Grand Total	34	4999	309	0	26	160	30	0	61	5458	45	0	225	167	71	0	11585
Apprch %	0.6	93.6	5.8	0	12	74.1	13.9	0	1.1	98.1	0.8	0	48.6	36.1	15.3	0	
Total %	0.3	43.2	2.7	0	0.2	1.4	0.3	0	0.5	47.1	0.4	0	1.9	1.4	0.6	0	
Unshifted	34	4999	309	0	26	160	30	0	61	5458	45	0	225	167	71	0	11585
% Unshifted	100	100	100	0	100	100	100	0	100	100	100	0	100	100	100	0	100
Bank 1	0	0	0	0	0	0	0	0	0	0	0	0	0	0	0	0	0
% Bank 1	0	0	0	0	0	0	0	0	0	0	0	0	0	0	0	0	0



MINNESOTA DEPT OF TRANSPORTATION

TRAFFIC DATA COLLECTION - METRO

TH-52 at 200th St / CSAH-66
 Ref.Pt; 109.822
 Jamar # T-2638 CAH
 TURN MOVEMENT COUNT

File Name : TH 52 at 200th ST CSAH 66
 Site Code : 109.822
 Start Date : 5/17/2011
 Page No : 2

Start Time	TH-52 Southbound					200th St / CSAH 66 Westbound					TH-52 Northbound					200th St / CSAH 66 Eastbound					Int. Total
	Left	Thru	Right	Peds	App. Total	Left	Thru	Right	Peds	App. Total	Left	Thru	Right	Peds	App. Total	Left	Thru	Right	Peds	App. Total	
Peak Hour Analysis From 06:00 to 08:45 - Peak 1 of 1																					
Peak Hour for Entire Intersection Begins at 06:45																					
06:45	0	155	6	0	161	2	11	3	0	16	2	302	1	0	305	9	4	1	0	14	496
07:00	0	168	9	0	177	2	7	3	0	12	1	299	4	0	304	19	5	4	0	28	521
07:15	0	179	8	0	187	0	2	0	0	2	2	326	3	0	331	18	3	3	0	24	544
07:30	1	161	8	0	170	2	6	0	0	8	4	304	1	0	309	20	11	4	0	35	522
Total Volume	1	663	31	0	695	6	26	6	0	38	9	1231	9	0	1249	66	23	12	0	101	2083
% App. Total	0.1	95.4	4.5	0		15.8	68.4	15.8	0		0.7	98.6	0.7	0		65.3	22.8	11.9	0		
PHF	.250	.926	.861	.000	.929	.750	.591	.500	.000	.594	.563	.944	.563	.000	.943	.825	.523	.750	.000	.721	.957

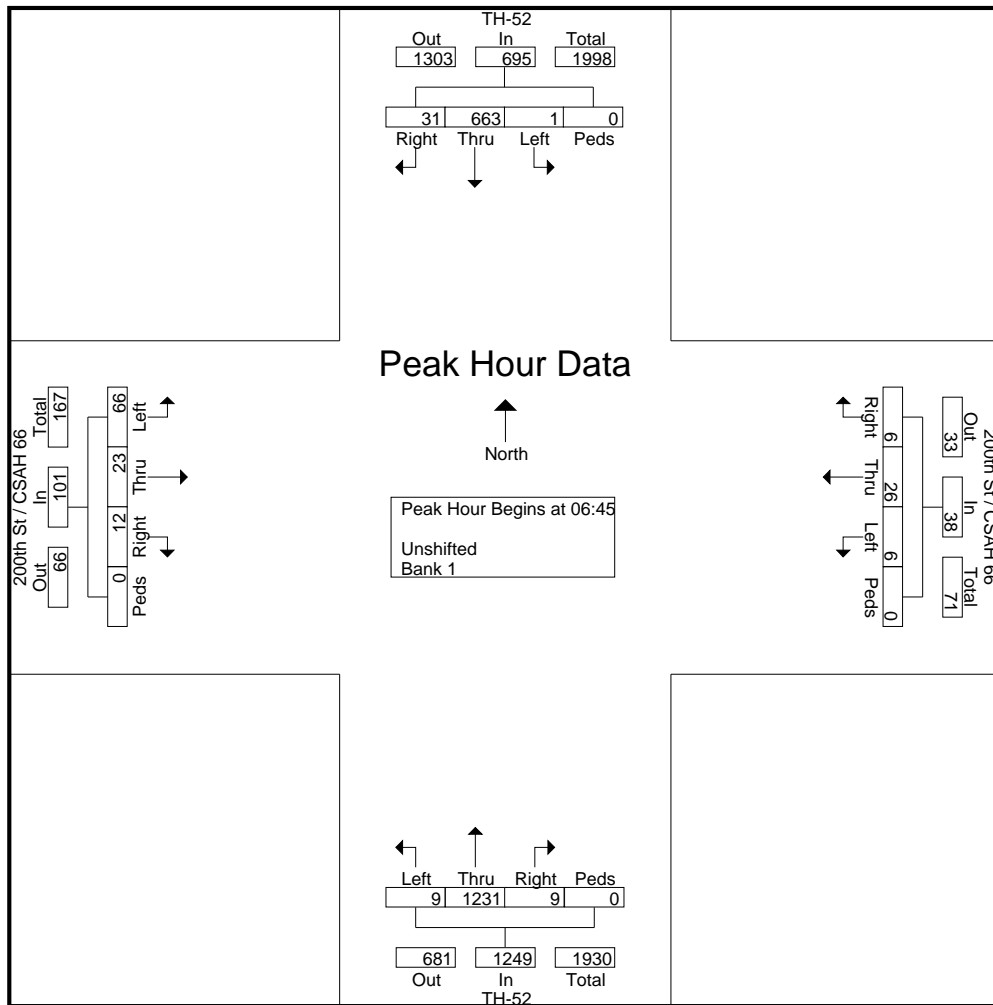



MINNESOTA DEPT OF TRANSPORTATION

TRAFFIC DATA COLLECTION - METRO

TH-52 at 200th St / CSAH-66
 Ref.Pt; 109.822
 Jamar # T-2638 CAH
 TURN MOVEMENT COUNT

File Name : TH 52 at 200th ST CSAH 66
 Site Code : 109.822
 Start Date : 5/17/2011
 Page No : 3

Start Time	TH-52 Southbound					200th St / CSAH 66 Westbound					TH-52 Northbound					200th St / CSAH 66 Eastbound					Int. Total
	Left	Thru	Right	Peds	App. Total	Left	Thru	Right	Peds	App. Total	Left	Thru	Right	Peds	App. Total	Left	Thru	Right	Peds	App. Total	
16:45	0	274	25	0	299	1	7	1	0	9	2	209	0	0	211	6	6	2	0	14	533
17:00	5	301	14	0	320	4	9	1	0	14	3	181	3	0	187	7	9	1	0	17	538
17:15	1	310	25	0	336	2	8	2	0	12	5	228	1	0	234	6	12	3	0	21	603
17:30	5	327	25	0	357	2	9	0	0	11	5	211	3	0	219	6	8	3	0	17	604
Total Volume	11	1212	89	0	1312	9	33	4	0	46	15	829	7	0	851	25	35	9	0	69	2278
% App. Total	0.8	92.4	6.8	0		19.6	71.7	8.7	0		1.8	97.4	0.8	0		36.2	50.7	13	0		
PHF	.550	.927	.890	.000	.919	.563	.917	.500	.000	.821	.750	.909	.583	.000	.909	.893	.729	.750	.000	.821	.943

Peak Hour Analysis From 15:00 to 17:45 - Peak 1 of 1
 Peak Hour for Entire Intersection Begins at 16:45

