

Associated Consulting Services (ACS)
Roseville, MN 55113
-- TRAFFIC DATA --

MN-51 at Bohland Ave_2022
City: St Paul
Data Prepared By: ACS
TURNING MOVEMENT COUNT

File Name : MN-51 at Bohland Ave_2022
Site Code :
Start Date : 5/3/2022
Page No : 1

Groups Printed- Cars - Trucks

Start Time	NN-51 Southbound				Private Road Westbound				NN-51 Northbound				Bohland Ave Eastbound				Int. Total
	Left	Thru	Right	Peds	Left	Thru	Right	Peds	Left	Thru	Right	Peds	Left	Thru	Right	Peds	
06:00	0	23	0	0	0	0	0	0	0	39	0	1	0	0	1	3	67
06:15	0	42	1	0	0	0	0	0	0	29	0	0	0	0	1	3	76
06:30	2	45	0	0	0	0	0	0	0	44	1	0	1	0	0	1	94
06:45	3	52	0	0	0	0	0	0	0	50	3	0	0	0	2	0	110
Total	5	162	1	0	0	0	0	0	0	162	4	1	1	0	4	7	347
07:00	0	64	2	0	0	0	0	1	0	59	0	2	1	0	1	0	130
07:15	0	86	1	0	0	0	1	1	0	84	0	2	0	0	0	1	176
07:30	1	79	1	0	0	0	2	0	3	80	0	0	2	0	2	1	171
07:45	0	106	2	0	1	0	1	0	2	102	0	0	1	0	0	7	222
Total	1	335	6	0	1	0	4	2	5	325	0	4	4	0	3	9	699
08:00	0	94	1	0	0	0	2	0	0	107	0	0	0	0	4	10	218
08:15	0	166	0	0	1	0	0	0	2	113	1	0	0	0	1	5	289
08:30	1	87	4	0	1	0	0	1	0	116	1	0	0	0	1	0	212
08:45	0	76	1	0	0	0	0	0	0	78	0	0	1	0	1	5	162
Total	1	423	6	0	2	0	2	1	2	414	2	0	1	0	7	20	881
09:00	0	79	0	0	0	0	0	0	0	68	1	0	0	0	0	0	148
09:15	2	81	0	0	0	0	0	2	0	101	0	0	0	0	0	0	186
09:30	0	61	0	0	5	0	1	1	0	93	0	0	0	0	0	3	164
09:45	0	73	1	0	0	0	0	0	0	65	1	0	0	0	2	2	144
Total	2	294	1	0	5	0	1	3	0	327	2	0	0	0	2	5	642
10:00	0	67	1	0	0	0	0	0	0	72	4	0	0	0	1	1	146
10:15	0	74	1	0	0	0	3	0	0	64	0	0	0	0	1	1	144
10:30	0	85	1	0	0	0	3	0	1	63	2	0	0	0	0	0	155
10:45	2	84	2	0	0	0	0	0	0	67	0	0	1	0	2	0	158
Total	2	310	5	0	0	0	6	0	1	266	6	0	1	0	4	2	603
11:00	1	67	0	0	1	0	3	0	0	74	0	0	2	0	0	1	149
11:15	1	77	0	0	0	0	0	0	2	77	0	0	4	0	0	2	163
11:30	4	74	1	0	0	0	2	0	0	84	0	0	0	0	0	0	165
11:45	1	82	0	0	0	0	0	0	1	69	2	0	0	0	0	3	158
Total	7	300	1	0	1	0	5	0	3	304	2	0	6	0	0	6	635
12:00	0	81	2	0	0	0	3	1	1	78	2	0	1	0	3	3	175
12:15	1	88	2	0	1	0	0	3	2	72	0	1	1	0	0	7	178
12:30	0	99	0	0	0	0	0	1	2	86	0	0	2	0	1	1	192
12:45	0	72	0	0	1	0	3	0	1	67	0	0	0	0	1	1	146
Total	1	340	4	0	2	0	6	5	6	303	2	1	4	0	5	12	691
13:00	1	82	1	0	1	0	0	0	1	86	0	0	1	0	1	0	174
13:15	1	89	1	0	1	0	0	0	0	83	0	0	1	0	0	3	179
13:30	0	91	0	0	0	0	0	1	0	76	0	1	3	0	1	3	176
13:45	1	89	1	0	0	0	1	0	1	100	0	1	0	0	0	0	194
Total	3	351	3	0	2	0	1	1	2	345	0	2	5	0	2	6	723
14:00	2	87	1	0	0	0	3	0	0	81	0	0	0	1	1	1	177
14:15	1	100	6	0	0	0	0	0	0	91	0	2	1	0	0	5	206
14:30	0	100	1	0	1	0	4	1	2	94	3	1	0	0	2	2	211
14:45	0	136	3	0	1	0	1	0	1	100	2	0	1	0	0	2	247
Total	3	423	11	0	2	0	8	1	3	366	5	3	2	1	3	10	841

Associated Consulting Services (ACS)
 Roseville, MN 55113
 -- TRAFFIC DATA --

MN-51 at Bohland Ave_2022
 City: St Paul
 Data Prepared By: ACS
 TURNING MOVEMENT COUNT

File Name : MN-51 at Bohland Ave_2022
 Site Code :
 Start Date : 5/3/2022
 Page No : 2

Groups Printed- Cars - Trucks

Start Time	NN-51 Southbound				Private Road Westbound				NN-51 Northbound				Bohland Ave Eastbound				Int. Total
	Left	Thru	Right	Peds	Left	Thru	Right	Peds	Left	Thru	Right	Peds	Left	Thru	Right	Peds	
15:00	0	151	4	0	0	0	1	1	1	125	0	0	1	0	3	31	318
15:15	0	145	1	0	0	0	0	2	0	137	1	1	1	0	2	12	302
15:30	0	125	3	0	2	0	4	3	1	110	0	2	0	0	0	4	254
15:45	0	115	0	0	0	0	0	16	2	101	0	0	0	0	1	9	244
Total	0	536	8	0	2	0	5	22	4	473	1	3	2	0	6	56	1118
16:00	0	137	1	0	0	0	0	1	0	127	1	2	0	0	0	7	276
16:15	0	109	0	0	0	0	0	0	2	114	3	0	1	0	1	3	233
16:30	0	122	2	0	0	0	3	0	1	138	0	0	1	0	0	1	268
16:45	0	135	2	0	0	0	1	0	0	126	1	0	0	0	1	6	272
Total	0	503	5	0	0	0	4	1	3	505	5	2	2	0	2	17	1049
17:00	0	131	2	0	0	0	0	4	2	131	1	0	2	0	2	10	285
17:15	0	124	3	0	0	0	1	2	0	127	1	0	1	0	0	6	265
17:30	0	130	1	0	0	0	0	5	2	131	0	0	1	0	0	4	274
17:45	0	122	1	0	0	0	0	7	2	98	0	0	0	0	1	5	236
Total	0	507	7	0	0	0	1	18	6	487	2	0	4	0	3	25	1060
Grand Total	25	4484	58	0	17	0	43	54	35	4277	31	16	32	1	41	175	9289
Apprch %	0.5	98.2	1.3	0	14.9	0	37.7	47.4	0.8	98.1	0.7	0.4	12.9	0.4	16.5	70.3	
Total %	0.3	48.3	0.6	0	0.2	0	0.5	0.6	0.4	46	0.3	0.2	0.3	0	0.4	1.9	
Cars	25	4191	52	0	17	0	42	54	34	4007	30	16	29	1	37	175	8710
% Cars	100	93.5	89.7	0	100	0	97.7	100	97.1	93.7	96.8	100	90.6	100	90.2	100	93.8
Trucks	0	293	6	0	0	0	1	0	1	270	1	0	3	0	4	0	579
% Trucks	0	6.5	10.3	0	0	0	2.3	0	2.9	6.3	3.2	0	9.4	0	9.8	0	6.2

Associated Consulting Services (ACS)
 Roseville, MN 55113
 -- TRAFFIC DATA --

MN-51 at Bohland Ave_2022
 City: St Paul
 Data Prepared By: ACS
 TURNING MOVEMENT COUNT

File Name : MN-51 at Bohland Ave_2022
 Site Code :
 Start Date : 5/3/2022
 Page No : 3

Start Time	NN-51 Southbound					Private Road Westbound					NN-51 Northbound					Bohland Ave Eastbound					Int. Total
	Left	Thru	Right	Peds	App. Total	Left	Thru	Right	Peds	App. Total	Left	Thru	Right	Peds	App. Total	Left	Thru	Right	Peds	App. Total	
Peak Hour Analysis From 06:00 to 11:45 - Peak 1 of 1																					
Peak Hour for Entire Intersection Begins at 07:45																					
07:45	0	106	2	0	108	1	0	1	0	2	2	102	0	0	104	1	0	0	7	8	222
08:00	0	94	1	0	95	0	0	2	0	2	0	107	0	0	107	0	0	4	10	14	218
08:15	0	166	0	0	166	1	0	0	0	1	2	113	1	0	116	0	0	1	5	6	289
08:30	1	87	4	0	92	1	0	0	1	2	0	116	1	0	117	0	0	1	0	1	212
Total Volume	1	453	7	0	461	3	0	3	1	7	4	438	2	0	444	1	0	6	22	29	941
% App. Total	0.2	98.3	1.5	0		42.9	0	42.9	14.3		0.9	98.6	0.5	0		3.4	0	20.7	75.9		
PHF	.250	.682	.438	.000	.694	.750	.000	.375	.250	.875	.500	.944	.500	.000	.949	.250	.000	.375	.550	.518	.814

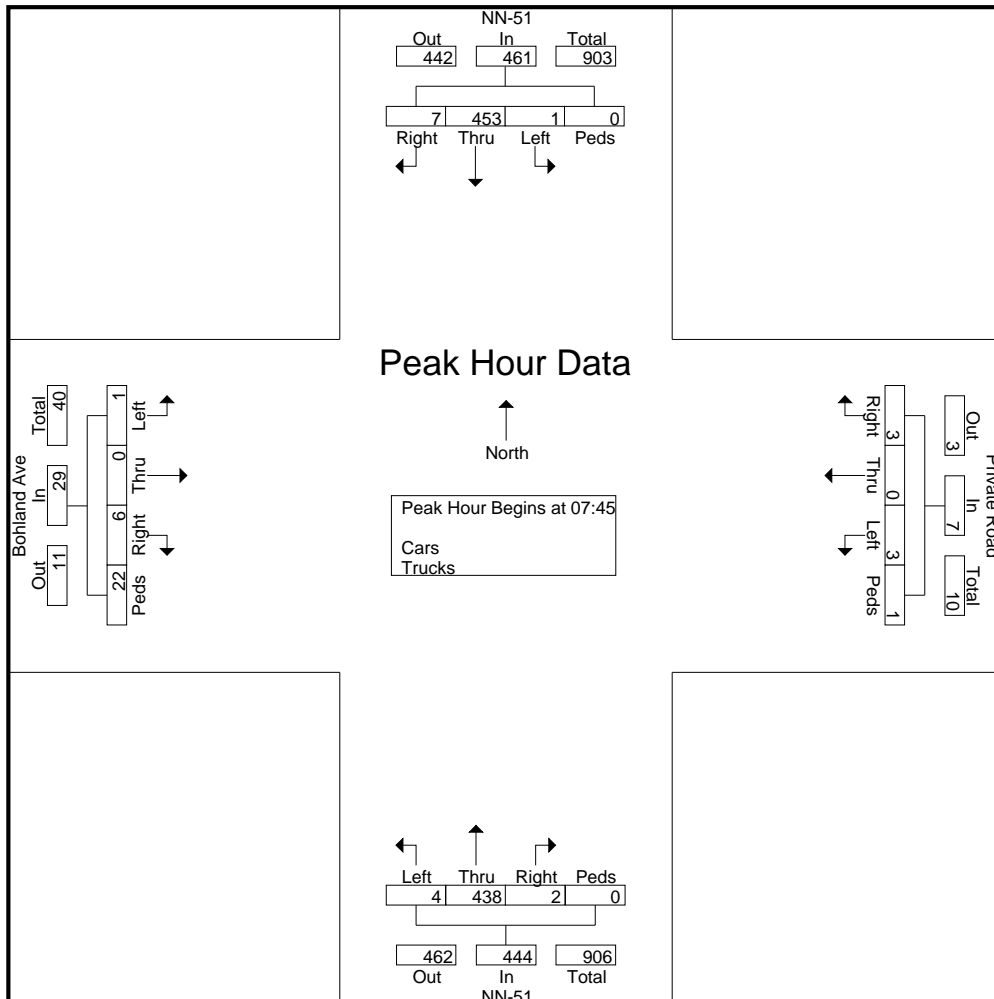

Associated Consulting Services (ACS)
 Roseville, MN 55113
 -- TRAFFIC DATA --

MN-51 at Bohland Ave_2022
 City: St Paul
 Data Prepared By: ACS
 TURNING MOVEMENT COUNT

File Name : MN-51 at Bohland Ave_2022
 Site Code :
 Start Date : 5/3/2022
 Page No : 4

Start Time	NN-51 Southbound					Private Road Westbound					NN-51 Northbound					Bohland Ave Eastbound					Int. Total
	Left	Thru	Right	Peds	App. Total	Left	Thru	Right	Peds	App. Total	Left	Thru	Right	Peds	App. Total	Left	Thru	Right	Peds	App. Total	
Peak Hour Analysis From 12:00 to 17:45 - Peak 1 of 1																					
Peak Hour for Entire Intersection Begins at 14:45																					
14:45	0	136	3	0	139	1	0	1	0	2	1	100	2	0	103	1	0	0	2	3	247
15:00	0	151	4	0	155	0	0	1	1	2	1	125	0	0	126	1	0	3	31	35	318
15:15	0	145	1	0	146	0	0	0	2	2	0	137	1	1	139	1	0	2	12	15	302
15:30	0	125	3	0	128	2	0	4	3	9	1	110	0	2	113	0	0	0	4	4	254
Total Volume	0	557	11	0	568	3	0	6	6	15	3	472	3	3	481	3	0	5	49	57	1121
% App. Total	0	98.1	1.9	0		20	0	40	40		0.6	98.1	0.6	0.6		5.3	0	8.8	86		
PHF	.000	.922	.688	.000	.916	.375	.000	.375	.500	.417	.750	.861	.375	.375	.865	.750	.000	.417	.395	.407	.881

