



701 Xenia Ave S, Suite 300
 Minneapolis, MN 55416

TH 5 & James Ave
 7-9am & 4-6pm
 vehicles, heavy trucks, peds
 day 2

File Name : site 34-TH 5 & James Ave-day 1
 Site Code : 34
 Start Date : 3/29/2022
 Page No : 1

Groups Printed- vehicles & peds - heavy trucks

Start Time	TH 5 From North					James Ave From East					TH 5 From South					James Ave From West					Int. Total
	Right	Thru	Left	Peds	App. Total	Right	Thru	Left	Peds	App. Total	Right	Thru	Left	Peds	App. Total	Right	Thru	Left	Peds	App. Total	
07:00 AM	1	37	0	0	38	0	0	1	0	1	2	36	0	0	38	2	0	0	1	3	80
07:15 AM	0	39	0	0	39	0	0	0	1	1	2	47	1	0	50	2	0	0	0	2	92
07:30 AM	2	51	0	0	53	0	0	0	0	0	1	56	0	0	57	1	0	1	2	4	114
07:45 AM	1	55	0	0	56	0	1	2	1	4	1	62	0	0	63	3	0	2	0	5	128
Total	4	182	0	0	186	0	1	3	2	6	6	201	1	0	208	8	0	3	3	14	414
08:00 AM	3	55	0	0	58	0	0	1	0	1	0	54	0	0	54	2	0	1	1	4	117
08:15 AM	2	52	0	2	56	0	0	3	1	4	2	67	1	1	71	4	0	2	1	7	138
08:30 AM	1	55	0	0	56	1	2	3	2	8	4	70	3	1	78	6	3	3	1	13	155
08:45 AM	1	44	0	1	46	1	1	0	0	2	1	54	2	0	57	4	0	2	0	6	111
Total	7	206	0	3	216	2	3	7	3	15	7	245	6	2	260	16	3	8	3	30	521
04:00 PM	4	73	2	0	79	0	0	0	0	0	1	84	2	2	89	6	0	6	1	13	181
04:15 PM	2	75	0	1	78	0	0	1	1	2	1	91	3	0	95	2	0	0	3	5	180
04:30 PM	5	77	1	2	85	3	0	2	1	6	3	93	2	2	100	1	0	1	4	6	197
04:45 PM	1	89	1	0	91	1	0	3	0	4	1	90	4	0	95	2	0	2	3	7	197
Total	12	314	4	3	333	4	0	6	2	12	6	358	11	4	379	11	0	9	11	31	755
05:00 PM	4	84	2	1	91	0	0	3	0	3	3	87	3	0	93	3	0	2	2	7	194
05:15 PM	5	87	0	0	92	1	1	1	1	4	2	106	5	2	115	1	1	1	5	8	219
05:30 PM	4	61	1	2	68	0	1	0	3	4	1	106	2	0	109	7	0	6	0	13	194
05:45 PM	6	70	1	4	81	5	0	0	0	5	1	111	5	11	128	1	0	2	3	6	220
Total	19	302	4	7	332	6	2	4	4	16	7	410	15	13	445	12	1	11	10	34	827
Grand Total	42	1004	8	13	1067	12	6	20	11	49	26	1214	33	19	1292	47	4	31	27	109	2517
Apprch %	3.9	94.1	0.7	1.2		24.5	12.2	40.8	22.4		2	94	2.6	1.5		43.1	3.7	28.4	24.8		
Total %	1.7	39.9	0.3	0.5	42.4	0.5	0.2	0.8	0.4	1.9	1	48.2	1.3	0.8	51.3	1.9	0.2	1.2	1.1	4.3	
vehicles & peds	42	1001	8	12	1063	12	6	20	7	45	26	1208	33	19	1286	47	4	31	25	107	2501
% vehicles & peds	100	99.7	100	92.3	99.6	100	100	100	63.6	91.8	100	99.5	100	100	99.5	100	100	100	92.6	98.2	99.4
heavy trucks	0	3	0	1	4	0	0	0	4	4	0	6	0	0	6	0	0	0	2	2	16
% heavy trucks	0	0.3	0	7.7	0.4	0	0	0	36.4	8.2	0	0.5	0	0	0.5	0	0	0	7.4	1.8	0.6

TH 5 & James Ave
 7-9am & 4-6pm
 vehicles, heavy trucks, peds
 day 2

File Name : site 34-TH 5 & James Ave-day 1
 Site Code : 34
 Start Date : 3/29/2022
 Page No : 2

Start Time	TH 5 From North					James Ave From East					TH 5 From South					James Ave From West					Int. Total
	Right	Thru	Left	Peds	App. Total	Right	Thru	Left	Peds	App. Total	Right	Thru	Left	Peds	App. Total	Right	Thru	Left	Peds	App. Total	
Peak Hour Analysis From 07:00 AM to 11:45 AM - Peak 1 of 1																					
Peak Hour for Entire Intersection Begins at 07:45 AM																					
07:45 AM	1	55	0	0	56	0	1	2	1	4	1	62	0	0	63	3	0	2	0	5	128
08:00 AM	3	55	0	0	58	0	0	1	0	1	0	54	0	0	54	2	0	1	1	4	117
08:15 AM	2	52	0	2	56	0	0	3	1	4	2	67	1	1	71	4	0	2	1	7	138
08:30 AM	1	55	0	0	56	1	2	3	2	8	4	70	3	1	78	6	3	3	1	13	155
Total Volume	7	217	0	2	226	1	3	9	4	17	7	253	4	2	266	15	3	8	3	29	538
% App. Total	3.1	96	0	0.9		5.9	17.6	52.9	23.5		2.6	95.1	1.5	0.8		51.7	10.3	27.6	10.3		
PHF	.583	.986	.000	.250	.974	.250	.375	.750	.500	.531	.438	.904	.333	.500	.853	.625	.250	.667	.750	.558	.868

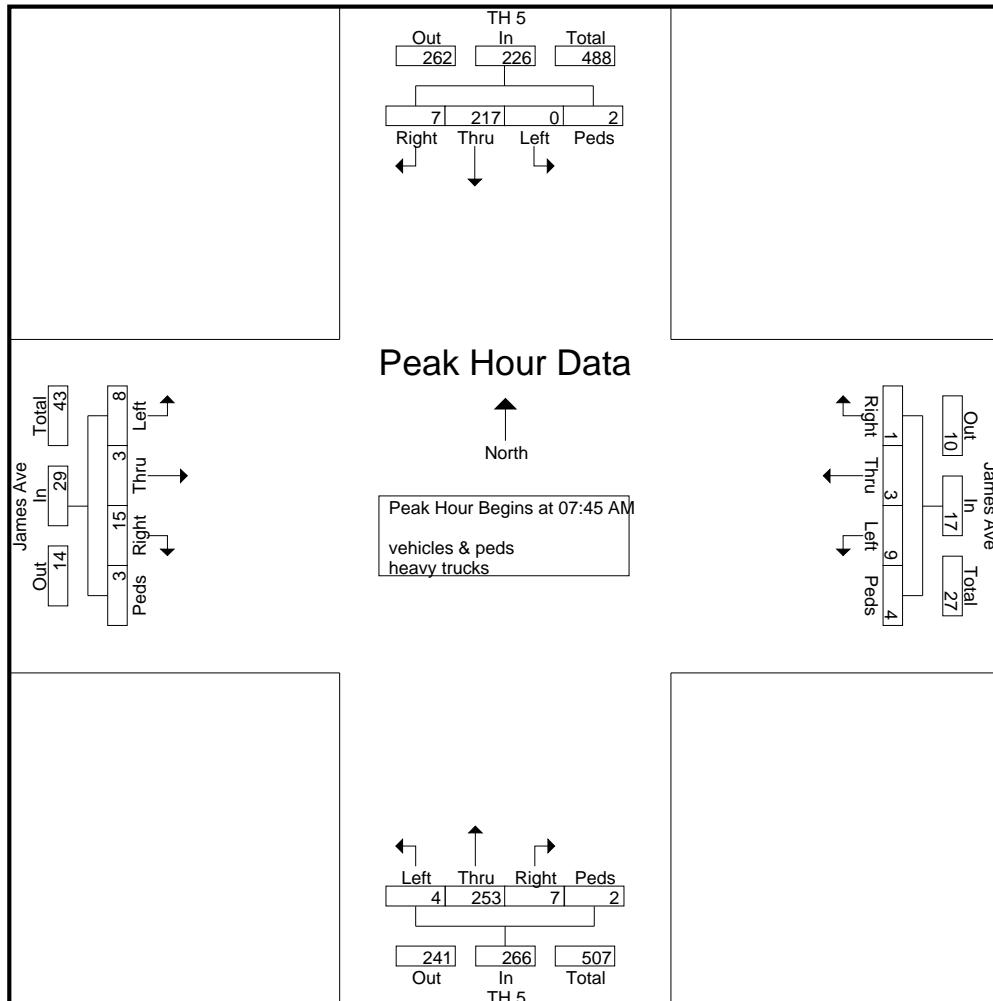

TH 5 & James Ave
 7-9am & 4-6pm
 vehicles, heavy trucks, peds
 day 2

File Name : site 34-TH 5 & James Ave-day 1
 Site Code : 34
 Start Date : 3/29/2022
 Page No : 3

Start Time	TH 5 From North					James Ave From East					TH 5 From South					James Ave From West					Int. Total
	Rig ht	Thr u	Left	Ped s	App. Total	Rig ht	Thr u	Left	Ped s	App. Total	Right	Thr u	Left	Peds	App. Total	Right	Thr u	Left	Peds	App. Total	
Peak Hour Analysis From 12:00 PM to 05:45 PM - Peak 1 of 1																					
Peak Hour for Entire Intersection Begins at 05:00 PM																					
05:00 PM	4	84	2	1	91	0	0	3	0	3	3	87	3	0	93	3	0	2	2	7	194
05:15 PM	5	87	0	0	92	1	1	1	1	4	2	106	5	2	115	1	1	1	5	8	219
05:30 PM	4	61	1	2	68	0	1	0	3	4	1	106	2	0	109	7	0	6	0	13	194
05:45 PM	6	70	1	4	81	5	0	0	0	5	1	111	5	11	128	1	0	2	3	6	220
Total Volume	19	302	4	7	332	6	2	4	4	16	7	410	15	13	445	12	1	11	10	34	827
% App. Total	5.7	91	1.2	2.1		37.5	12.5	25	25		1.6	92.1	3.4	2.9		35.3	2.9	32.4	29.4		
PHF	.792	.868	.500	.438	.902	.300	.500	.333	.333	.800	.583	.923	.750	.295	.869	.429	.250	.458	.500	.654	.940

