



# MINNESOTA DEPT OF TRANSPORTATION

## TRAFFIC DATA COLLECTION - METRO

TH-5 at Venture Lane / Fuller Rd.  
 Ref.Pt.: 048.249  
 Data by: Westwood Professional Services  
 TURN MOVEMENT COUNT

File Name : TH-5 at Venture Ln-Fuller Rd 2008  
 Site Code : 19052001  
 Start Date : 10/1/2008  
 Page No : 1

**Groups Printed- Unshifted**

Start Time	Venture Lane Southbound				TH-5 Westbound				Fuller Rd Northbound				TH-5 Eastbound				Int. Total
	Left	Thru	Right	Peds	Left	Thru	Right	Peds	Left	Thru	Right	Peds	Left	Thru	Right	Peds	
06:00	0	1	1	0	27	170	0	0	3	1	6	0	2	224	6	0	441
06:15	0	1	2	0	33	174	2	0	0	1	5	0	5	350	10	0	583
06:30	1	9	2	0	42	230	10	0	1	0	4	0	5	405	15	0	724
06:45	0	13	5	0	33	229	14	0	0	1	5	0	7	408	13	0	728
<b>Total</b>	<b>1</b>	<b>24</b>	<b>10</b>	<b>0</b>	<b>135</b>	<b>803</b>	<b>26</b>	<b>0</b>	<b>4</b>	<b>3</b>	<b>20</b>	<b>0</b>	<b>19</b>	<b>1387</b>	<b>44</b>	<b>0</b>	<b>2476</b>
07:00	0	3	1	0	22	249	3	0	0	0	5	0	7	572	10	0	872
07:15	0	0	3	0	17	333	5	0	1	0	2	0	9	613	9	0	992
07:30	0	1	1	0	19	362	1	0	0	0	17	0	16	645	9	0	1071
07:45	0	0	3	0	26	314	3	0	1	0	8	0	22	690	17	0	1084
<b>Total</b>	<b>0</b>	<b>4</b>	<b>8</b>	<b>0</b>	<b>84</b>	<b>1258</b>	<b>12</b>	<b>0</b>	<b>2</b>	<b>0</b>	<b>32</b>	<b>0</b>	<b>54</b>	<b>2520</b>	<b>45</b>	<b>0</b>	<b>4019</b>
08:00	1	1	5	0	19	335	3	0	1	0	6	0	13	573	10	0	967
08:15	0	2	4	0	17	305	3	0	1	1	7	0	6	504	4	0	854
08:30	2	1	4	0	8	298	3	0	1	1	4	0	6	447	9	0	784
08:45	1	2	4	0	17	313	6	0	4	0	4	0	6	409	5	0	771
<b>Total</b>	<b>4</b>	<b>6</b>	<b>17</b>	<b>0</b>	<b>61</b>	<b>1251</b>	<b>15</b>	<b>0</b>	<b>7</b>	<b>2</b>	<b>21</b>	<b>0</b>	<b>31</b>	<b>1933</b>	<b>28</b>	<b>0</b>	<b>3376</b>
*** BREAK ***																	
11:00	9	1	11	0	9	253	7	0	6	0	8	0	6	315	4	0	629
11:15	6	3	10	0	10	282	4	0	6	0	15	0	5	341	7	0	689
11:30	3	0	12	0	9	316	3	0	11	1	22	0	9	373	6	0	765
11:45	4	0	16	0	8	326	1	0	11	1	16	0	15	348	12	0	758
<b>Total</b>	<b>22</b>	<b>4</b>	<b>49</b>	<b>0</b>	<b>36</b>	<b>1177</b>	<b>15</b>	<b>0</b>	<b>34</b>	<b>2</b>	<b>61</b>	<b>0</b>	<b>35</b>	<b>1377</b>	<b>29</b>	<b>0</b>	<b>2841</b>
12:00	4	2	20	0	13	346	4	0	12	0	18	0	11	360	9	0	799
12:15	3	4	12	0	4	346	5	0	7	1	9	0	7	341	7	0	746
12:30	3	2	13	0	7	330	4	0	4	0	3	0	17	374	10	0	767
12:45	0	0	9	0	12	348	5	0	9	1	5	0	13	333	9	0	744
<b>Total</b>	<b>10</b>	<b>8</b>	<b>54</b>	<b>0</b>	<b>36</b>	<b>1370</b>	<b>18</b>	<b>0</b>	<b>32</b>	<b>2</b>	<b>35</b>	<b>0</b>	<b>48</b>	<b>1408</b>	<b>35</b>	<b>0</b>	<b>3056</b>
*** BREAK ***																	
15:00	2	0	10	0	23	412	4	0	7	2	23	0	4	451	13	0	951
15:15	5	7	15	0	28	416	11	0	6	2	36	0	2	385	12	0	925
15:30	0	10	13	0	30	442	11	0	7	1	74	0	4	421	3	0	1016
15:45	2	3	18	0	16	466	5	0	11	1	27	0	3	351	4	0	907
<b>Total</b>	<b>9</b>	<b>20</b>	<b>56</b>	<b>0</b>	<b>97</b>	<b>1736</b>	<b>31</b>	<b>0</b>	<b>31</b>	<b>6</b>	<b>160</b>	<b>0</b>	<b>13</b>	<b>1608</b>	<b>32</b>	<b>0</b>	<b>3799</b>
16:00	1	2	15	0	4	492	2	0	13	1	32	0	3	352	5	0	922
16:15	2	1	28	0	5	533	4	0	10	1	18	0	4	352	9	0	967
16:30	1	1	21	0	7	526	1	0	20	1	23	0	8	430	4	0	1043
16:45	4	1	24	0	4	489	5	0	6	1	17	0	5	373	1	0	930
<b>Total</b>	<b>8</b>	<b>5</b>	<b>88</b>	<b>0</b>	<b>20</b>	<b>2040</b>	<b>12</b>	<b>0</b>	<b>49</b>	<b>4</b>	<b>90</b>	<b>0</b>	<b>20</b>	<b>1507</b>	<b>19</b>	<b>0</b>	<b>3862</b>
17:00	4	0	24	0	4	560	3	0	6	2	21	0	4	434	0	0	1062
17:15	1	2	20	0	1	539	1	0	7	1	20	0	4	415	4	0	1015
17:30	2	0	18	0	9	565	1	0	9	1	22	0	5	445	11	0	1088
17:45	1	0	10	0	2	546	5	0	10	2	14	0	6	335	3	0	934
<b>Total</b>	<b>8</b>	<b>2</b>	<b>72</b>	<b>0</b>	<b>16</b>	<b>2210</b>	<b>10</b>	<b>0</b>	<b>32</b>	<b>6</b>	<b>77</b>	<b>0</b>	<b>19</b>	<b>1629</b>	<b>18</b>	<b>0</b>	<b>4099</b>
<b>Grand Total</b>	<b>62</b>	<b>73</b>	<b>354</b>	<b>0</b>	<b>485</b>	<b>11845</b>	<b>139</b>	<b>0</b>	<b>191</b>	<b>25</b>	<b>496</b>	<b>0</b>	<b>239</b>	<b>13369</b>	<b>250</b>	<b>0</b>	<b>27528</b>
Apprch %	12.7	14.9	72.4	0	3.9	95	1.1	0	26.8	3.5	69.7	0	1.7	96.5	1.8	0	
Total %	0.2	0.3	1.3	0	1.8	43	0.5	0	0.7	0.1	1.8	0	0.9	48.6	0.9	0	



# MINNESOTA DEPT OF TRANSPORTATION

TRAFFIC DATA COLLECTION - METRO

TH-5 at Venture Lane / Fuller Rd.  
 Ref.Pt.: 048.249  
 Data by: Westwood Professional Services  
 TURN MOVEMENT COUNT

File Name : TH-5 at Venture Ln-Fuller Rd 2008  
 Site Code : 19052001  
 Start Date : 10/1/2008  
 Page No : 2

Start Time	Venture Lane Southbound					TH-5 Westbound					Fuller Rd Northbound					TH-5 Eastbound					Int. Total
	Left	Thru	Right	Peds	App. Total	Left	Thru	Right	Peds	App. Total	Left	Thru	Right	Peds	App. Total	Left	Thru	Right	Peds	App. Total	
Peak Hour Analysis From 06:00 to 08:45 - Peak 1 of 1																					
Peak Hour for Entire Intersection Begins at 07:15																					
07:15	0	0	3	0	3	17	333	5	0	355	1	0	2	0	3	9	613	9	0	631	992
07:30	0	1	1	0	2	19	362	1	0	382	0	0	17	0	17	16	645	9	0	670	1071
07:45	0	0	3	0	3	26	314	3	0	343	1	0	8	0	9	22	690	17	0	729	1084
08:00	1	1	5	0	7	19	335	3	0	357	1	0	6	0	7	13	573	10	0	596	967
Total Volume	1	2	12	0	15	81	1344	12	0	1437	3	0	33	0	36	60	2521	45	0	2626	4114
% App. Total	6.7	13.3	80	0		5.6	93.5	0.8	0		8.3	0	91.7	0		2.3	96	1.7	0		
PHF	.250	.500	.600	.000	.536	.779	.928	.600	.000	.940	.750	.000	.485	.000	.529	.682	.913	.662	.000	.901	.949

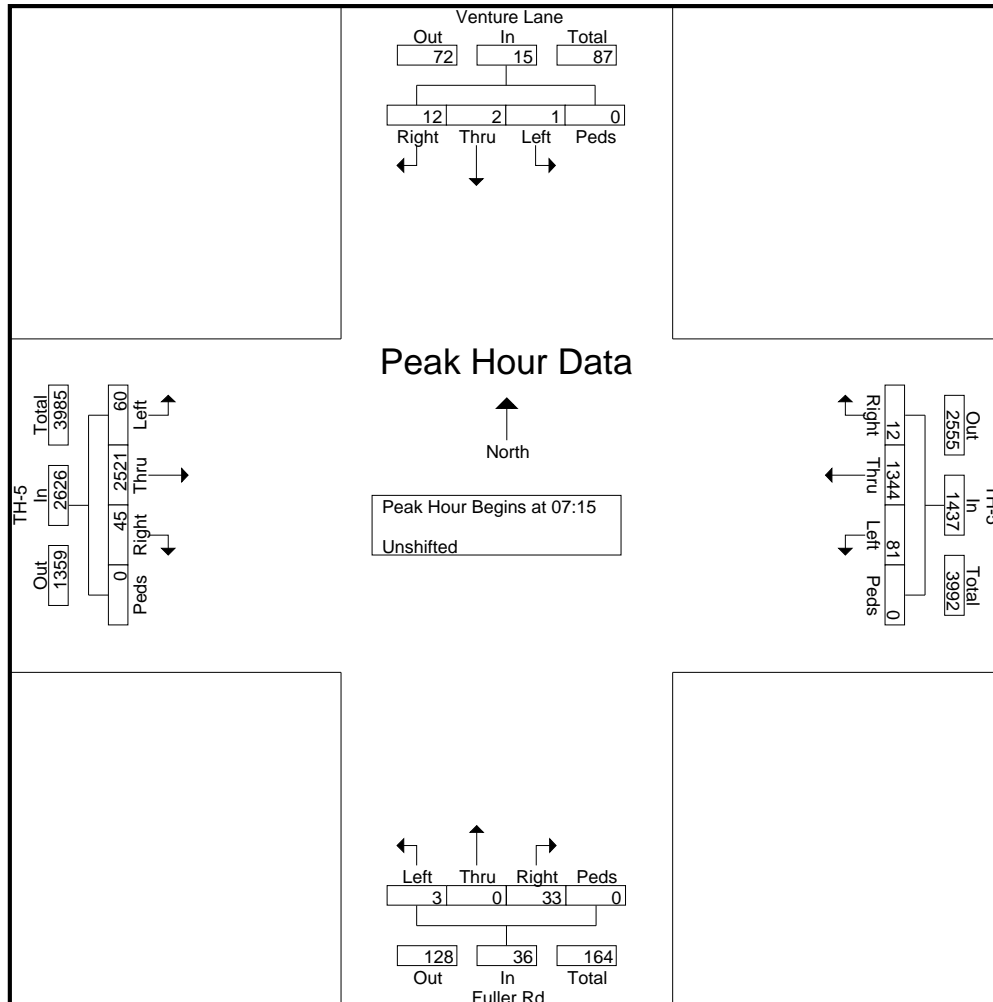



# MINNESOTA DEPT OF TRANSPORTATION

## TRAFFIC DATA COLLECTION - METRO

TH-5 at Venture Lane / Fuller Rd.  
 Ref.Pt.: 048.249  
 Data by: Westwood Professional Services  
 TURN MOVEMENT COUNT

File Name : TH-5 at Venture Ln-Fuller Rd 2008  
 Site Code : 19052001  
 Start Date : 10/1/2008  
 Page No : 3

Start Time	Venture Lane Southbound					TH-5 Westbound					Fuller Rd Northbound					TH-5 Eastbound					Int. Total
	Left	Thru	Right	Peds	App. Total	Left	Thru	Right	Peds	App. Total	Left	Thru	Right	Peds	App. Total	Left	Thru	Right	Peds	App. Total	

Peak Hour Analysis From 15:00 to 17:45 - Peak 1 of 1

Peak Hour for Entire Intersection Begins at 17:00

17:00	4	0	24	0	28	4	560	3	0	567	6	2	21	0	29	4	434	0	0	438	1062
17:15	1	2	20	0	23	1	539	1	0	541	7	1	20	0	28	4	415	4	0	423	1015
17:30	2	0	18	0	20	9	565	1	0	575	9	1	22	0	32	5	445	11	0	461	1088
17:45	1	0	10	0	11	2	546	5	0	553	10	2	14	0	26	6	335	3	0	344	934
Total Volume	8	2	72	0	82	16	2210	10	0	2236	32	6	77	0	115	19	1629	18	0	1666	4099
% App. Total	9.8	2.4	87.8	0		0.7	98.8	0.4	0		27.8	5.2	67	0		1.1	97.8	1.1	0		
PHF	.500	.250	.750	.000	.732	.444	.978	.500	.000	.972	.800	.750	.875	.000	.898	.792	.915	.409	.000	.903	.942

