



MINNESOTA DEPT OF TRANSPORTATION

TRAFFIC DATA COLLECTION - METRO

TH-5 at Great Plains Blvd. CHANHASSEN
 Ref.Pt.: 045.733
 Data by: Westwood Professional Services
 TURN MOVEMENT COUNT

File Name : TH-5 at Great Plains Blvd 2008
 Site Code : 11052030
 Start Date : 9/30/2008
 Page No : 1

Groups Printed- Unshifted

Start Time	Great Plains Blvd. Southbound				TH-5 Westbound				Great Plains Blvd. Northbound				TH-5 Eastbound				Int. Total
	Left	Thru	Right	Peds	Left	Thru	Right	Peds	Left	Thru	Right	Peds	Left	Thru	Right	Peds	
06:00	8	1	0	1	7	109	7	0	3	3	2	0	4	197	4	0	346
06:15	18	5	4	0	6	144	13	0	1	2	11	0	2	236	2	0	444
06:30	23	8	8	0	6	143	15	0	5	4	10	0	5	293	1	0	521
06:45	24	6	11	0	6	171	27	0	3	6	9	0	8	315	13	0	599
Total	73	20	23	1	25	567	62	0	12	15	32	0	19	1041	20	0	1910
07:00	24	7	10	0	5	198	19	0	4	13	3	0	2	378	7	0	670
07:15	33	17	7	0	8	189	22	0	9	16	15	0	12	401	11	0	740
07:30	38	12	6	0	19	216	28	0	7	16	27	0	11	480	14	0	874
07:45	27	11	17	0	27	287	28	0	10	16	33	0	21	412	13	0	902
Total	122	47	40	0	59	890	97	0	30	61	78	0	46	1671	45	0	3186
08:00	31	13	13	0	18	177	15	0	15	18	23	0	39	384	9	0	755
08:15	37	14	17	0	14	232	28	0	7	6	20	0	13	319	10	0	717
08:30	31	11	3	0	14	205	18	0	3	7	18	0	8	271	21	0	610
08:45	35	18	10	0	24	229	37	0	13	18	33	0	26	226	26	0	695
Total	134	56	43	0	70	843	98	0	38	49	94	0	86	1200	66	0	2777
*** BREAK ***																	
11:00	33	11	4	0	17	137	31	0	16	21	36	0	7	200	16	0	529
11:15	28	10	10	0	23	188	34	0	13	15	25	0	10	235	19	0	610
11:30	38	14	3	0	20	229	55	0	23	21	25	0	7	251	29	0	715
11:45	31	13	5	0	24	197	55	0	18	20	26	0	12	231	28	0	660
Total	130	48	22	0	84	751	175	0	70	77	112	0	36	917	92	0	2514
12:00	44	24	11	0	12	211	52	0	32	15	38	0	18	209	21	0	687
12:15	50	22	10	0	11	241	36	0	21	19	22	0	9	230	27	0	698
12:30	57	30	6	0	17	205	32	0	23	17	21	0	5	228	25	0	666
12:45	40	17	16	0	15	239	39	0	16	14	24	0	14	222	24	0	680
Total	191	93	43	0	55	896	159	0	92	65	105	0	46	889	97	0	2731
*** BREAK ***																	
15:00	29	16	9	0	19	270	41	0	13	14	29	0	20	322	11	0	793
15:15	29	18	15	0	33	305	42	0	15	16	15	0	14	261	14	0	777
15:30	38	20	12	0	25	315	47	0	21	16	20	0	7	277	14	0	812
15:45	31	17	11	0	26	360	62	0	21	8	29	0	8	236	17	0	826
Total	127	71	47	0	103	1250	192	0	70	54	93	0	49	1096	56	0	3208
16:00	33	14	11	0	23	353	55	0	26	12	20	0	12	259	12	0	830
16:15	30	16	5	0	20	375	67	0	25	21	12	0	16	228	12	0	827
16:30	42	19	17	0	28	391	56	0	17	11	28	0	11	292	17	0	929
16:45	34	12	10	0	20	350	59	0	18	17	27	0	16	247	19	0	829
Total	139	61	43	0	91	1469	237	0	86	61	87	0	55	1026	60	0	3415
17:00	32	25	27	0	20	408	65	0	19	22	22	0	11	321	21	0	993
17:15	35	21	17	0	13	407	76	0	20	13	27	0	11	266	24	0	930
17:30	31	24	16	0	15	388	63	0	24	22	15	0	11	291	18	0	918
17:45	57	22	12	0	16	340	73	0	22	25	23	0	8	239	17	0	854
Total	155	92	72	0	64	1543	277	0	85	82	87	0	41	1117	80	0	3695
Grand Total	1071	488	333	1	551	8209	1297	0	483	464	688	0	378	8957	516	0	23436
Apprch %	56.6	25.8	17.6	0.1	5.5	81.6	12.9	0	29.5	28.4	42.1	0	3.8	90.9	5.2	0	
Total %	4.6	2.1	1.4	0	2.4	35	5.5	0	2.1	2	2.9	0	1.6	38.2	2.2	0	



MINNESOTA DEPT OF TRANSPORTATION

TRAFFIC DATA COLLECTION - METRO

TH-5 at Great Plains Blvd. CHANHASSEN
 Ref.Pt.: 045.733
 Data by: Westwood Professional Services
 TURN MOVEMENT COUNT

File Name : TH-5 at Great Plains Blvd 2008
 Site Code : 11052030
 Start Date : 9/30/2008
 Page No : 2

Start Time	Great Plains Blvd. Southbound					TH-5 Westbound					Great Plains Blvd. Northbound					TH-5 Eastbound					Int. Total
	Left	Thru	Right	Peds	App. Total	Left	Thru	Right	Peds	App. Total	Left	Thru	Right	Peds	App. Total	Left	Thru	Right	Peds	App. Total	
Peak Hour Analysis From 06:00 to 08:45 - Peak 1 of 1																					
Peak Hour for Entire Intersection Begins at 07:15																					
07:15	33	17	7	0	57	8	189	22	0	219	9	16	15	0	40	12	401	11	0	424	740
07:30	38	12	6	0	56	19	216	28	0	263	7	16	27	0	50	11	480	14	0	505	874
07:45	27	11	17	0	55	27	287	28	0	342	10	16	33	0	59	21	412	13	0	446	902
08:00	31	13	13	0	57	18	177	15	0	210	15	18	23	0	56	39	384	9	0	432	755
Total Volume	129	53	43	0	225	72	869	93	0	1034	41	66	98	0	205	83	1677	47	0	1807	3271
% App. Total	57.3	23.6	19.1	0		7	84	9	0		20	32.2	47.8	0		4.6	92.8	2.6	0		
PHF	.849	.779	.632	.000	.987	.667	.757	.830	.000	.756	.683	.917	.742	.000	.869	.532	.873	.839	.000	.895	.907

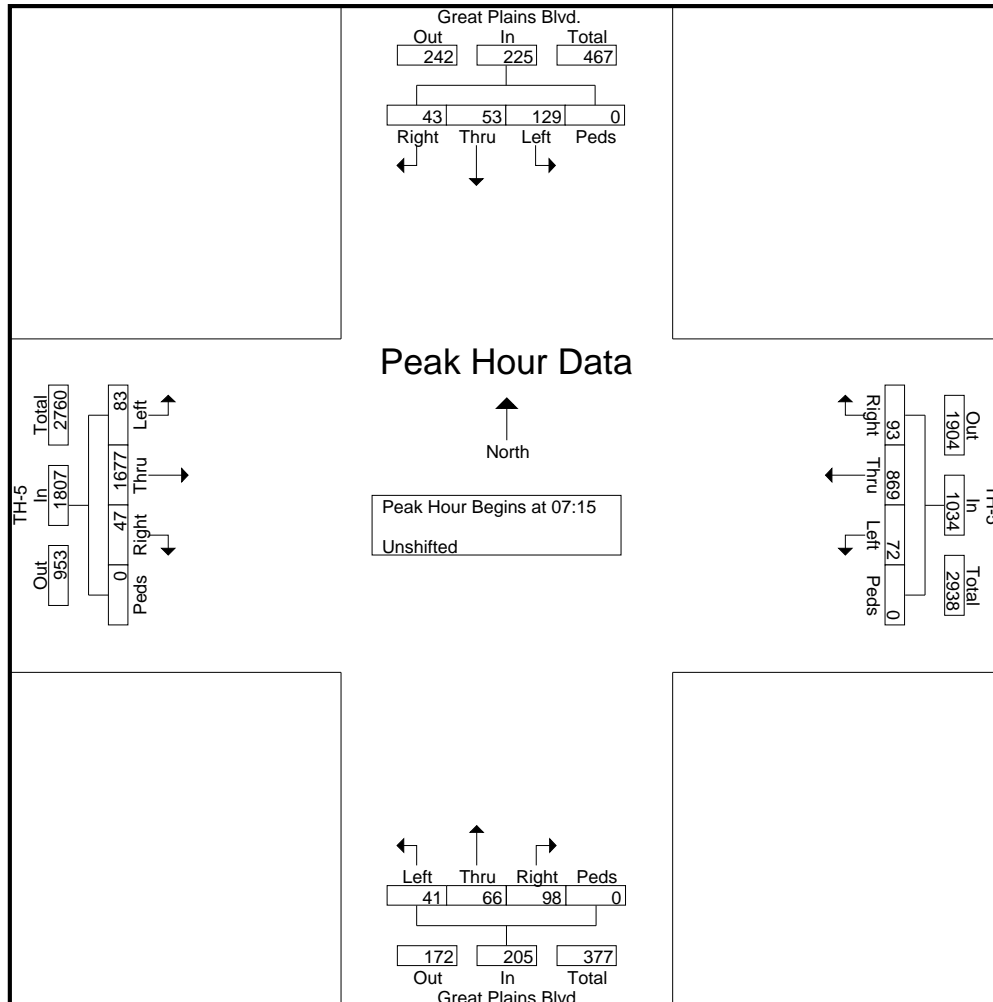



MINNESOTA DEPT OF TRANSPORTATION

TRAFFIC DATA COLLECTION - METRO

TH-5 at Great Plains Blvd. CHANHASSEN
 Ref.Pt.: 045.733
 Data by: Westwood Professional Services
 TURN MOVEMENT COUNT

File Name : TH-5 at Great Plains Blvd 2008
 Site Code : 11052030
 Start Date : 9/30/2008
 Page No : 3

Start Time	Great Plains Blvd. Southbound					TH-5 Westbound					Great Plains Blvd. Northbound					TH-5 Eastbound					Int. Total
	Left	Thru	Right	Peds	App. Total	Left	Thru	Right	Peds	App. Total	Left	Thru	Right	Peds	App. Total	Left	Thru	Right	Peds	App. Total	

Peak Hour Analysis From 15:00 to 17:45 - Peak 1 of 1

Peak Hour for Entire Intersection Begins at 17:00

17:00	32	25	27	0	84	20	408	65	0	493	19	22	22	0	63	11	321	21	0	353	993
17:15	35	21	17	0	73	13	407	76	0	496	20	13	27	0	60	11	266	24	0	301	930
17:30	31	24	16	0	71	15	388	63	0	466	24	22	15	0	61	11	291	18	0	320	918
17:45	57	22	12	0	91	16	340	73	0	429	22	25	23	0	70	8	239	17	0	264	854
Total Volume	155	92	72	0	319	64	1543	277	0	1884	85	82	87	0	254	41	1117	80	0	1238	3695
% App. Total	48.6	28.8	22.6	0		3.4	81.9	14.7	0		33.5	32.3	34.3	0		3.3	90.2	6.5	0		
PHF	.680	.920	.667	.000	.876	.800	.945	.911	.000	.950	.885	.820	.806	.000	.907	.932	.870	.833	.000	.877	.930

