



# MINNESOTA DEPT OF TRANSPORTATION

## TRAFFIC DATA COLLECTION - METRO

TH-5 at Galpin Blvd. CHANHASSEN  
 Ref.Pt.: 043.274  
 Data by: Westwood Professional Services  
 TURN MOVEMENT COUNT

File Name : TH-5 at Galpin Blvd 2008 CHANHASSEN  
 Site Code : 07052523  
 Start Date : 9/23/2008  
 Page No : 1

**Groups Printed- Unshifted**

Start Time	Galpin Blvd. Southbound				TH-5 Westbound				Galpin Blvd. Northbound				TH-5 Eastbound				Int. Total
	Left	Thru	Right	Peds	Left	Thru	Right	Peds	Left	Thru	Right	Peds	Left	Thru	Right	Peds	
06:00	10	3	4	0	0	0	0	0	0	0	0	0	1	154	4	1	177
06:15	12	5	4	0	1	94	8	0	3	4	15	0	4	225	5	0	380
06:30	21	2	5	0	7	124	10	0	3	6	33	0	6	248	4	0	469
06:45	18	11	5	0	7	140	13	0	2	3	31	0	6	298	2	0	536
Total	61	21	18	0	15	358	31	0	8	13	79	0	17	925	15	1	1562
07:00	29	15	3	0	9	99	27	0	7	5	30	0	4	338	4	0	570
07:15	39	14	3	0	16	75	8	0	4	8	44	0	8	378	7	0	604
07:30	44	28	13	0	9	129	4	0	4	10	49	0	8	388	8	0	694
07:45	40	25	9	0	30	237	22	0	1	7	37	0	3	374	8	0	793
Total	152	82	28	0	64	540	61	0	16	30	160	0	23	1478	27	0	2661
08:00	41	8	10	0	14	198	20	0	2	5	29	0	5	285	10	0	627
08:15	15	16	6	0	18	211	16	0	4	1	29	0	3	236	6	0	561
08:30	21	9	3	0	17	204	12	0	3	1	17	0	8	248	10	0	553
08:45	13	24	7	0	17	204	12	0	4	10	19	0	8	175	11	0	504
Total	90	57	26	0	66	817	60	0	13	17	94	0	24	944	37	0	2245
*** BREAK ***																	
11:00	12	8	6	0	13	149	14	0	3	7	22	0	7	189	5	0	435
11:15	21	7	5	0	8	142	10	0	9	8	27	0	13	188	4	0	442
11:30	17	14	7	0	13	167	12	0	7	6	21	0	9	236	7	0	516
11:45	20	6	11	0	24	121	16	0	3	5	16	2	4	197	6	0	431
Total	70	35	29	0	58	579	52	0	22	26	86	2	33	810	22	0	1824
12:00	15	7	4	0	12	168	21	0	5	15	23	0	13	212	3	0	498
12:15	11	9	9	0	14	166	20	0	4	7	17	0	10	200	3	0	470
12:30	24	10	9	0	21	205	17	0	6	5	15	0	16	151	7	0	486
12:45	20	15	11	0	21	153	20	0	6	7	16	0	6	182	5	0	462
Total	70	41	33	0	68	692	78	0	21	34	71	0	45	745	18	0	1916
*** BREAK ***																	
15:00	8	6	8	0	10	262	23	0	15	21	20	0	16	197	6	0	592
15:15	9	8	10	0	17	255	12	0	4	11	17	0	11	198	4	0	556
15:30	21	14	19	0	26	300	25	0	9	32	24	0	20	188	8	0	686
15:45	12	15	16	0	19	320	25	0	16	17	20	0	5	179	4	0	648
Total	50	43	53	0	72	1137	85	0	44	81	81	0	52	762	22	0	2482
16:00	8	8	14	0	17	261	38	0	10	10	24	0	6	186	7	0	589
16:15	6	12	19	0	21	270	22	0	7	11	12	0	11	205	4	0	600
16:30	11	9	11	0	10	265	27	0	7	21	22	0	11	233	3	0	630
16:45	10	15	11	0	19	310	35	0	6	15	25	0	5	212	10	0	673
Total	35	44	55	0	67	1106	122	0	30	57	83	0	33	836	24	0	2492
17:00	11	23	15	0	24	270	48	0	10	22	29	0	9	202	2	0	665
17:15	22	18	17	0	23	273	48	0	8	14	9	0	10	208	11	0	661
17:30	6	7	9	0	17	334	42	0	6	17	22	0	9	183	6	0	658
17:45	17	9	16	0	23	258	42	0	5	13	13	0	10	178	1	0	585
Total	56	57	57	0	87	1135	180	0	29	66	73	0	38	771	20	0	2569
Grand Total	584	380	299	0	497	6364	669	0	183	324	727	2	265	7271	185	1	17751
Apprch %	46.2	30.1	23.7	0	6.6	84.5	8.9	0	14.8	26.2	58.8	0.2	3.4	94.2	2.4	0	
Total %	3.3	2.1	1.7	0	2.8	35.9	3.8	0	1	1.8	4.1	0	1.5	41	1	0	



# MINNESOTA DEPT OF TRANSPORTATION

## TRAFFIC DATA COLLECTION - METRO

TH-5 at Galpin Blvd. CHANHASSEN  
 Ref.Pt.: 043.274  
 Data by: Westwood Professional Services  
 TURN MOVEMENT COUNT

File Name : TH-5 at Galpin Blvd 2008 CHANHASSEN  
 Site Code : 07052523  
 Start Date : 9/23/2008  
 Page No : 2

Start Time	Galpin Blvd. Southbound					TH-5 Westbound					Galpin Blvd. Northbound					TH-5 Eastbound					Int. Total
	Left	Thru	Right	Peds	App. Total	Left	Thru	Right	Peds	App. Total	Left	Thru	Right	Peds	App. Total	Left	Thru	Right	Peds	App. Total	
Peak Hour Analysis From 06:00 to 08:45 - Peak 1 of 1																					
Peak Hour for Entire Intersection Begins at 07:15																					
07:15	39	14	3	0	56	16	75	8	0	99	4	8	44	0	56	8	378	7	0	393	604
07:30	44	28	13	0	85	9	129	4	0	142	4	10	49	0	63	8	388	8	0	404	694
07:45	40	25	9	0	74	30	237	22	0	289	1	7	37	0	45	3	374	8	0	385	793
08:00	41	8	10	0	59	14	198	20	0	232	2	5	29	0	36	5	285	10	0	300	627
Total Volume	164	75	35	0	274	69	639	54	0	762	11	30	159	0	200	24	1425	33	0	1482	2718
% App. Total	59.9	27.4	12.8	0		9.1	83.9	7.1	0		5.5	15	79.5	0		1.6	96.2	2.2	0		
PHF	.932	.670	.673	.000	.806	.575	.674	.614	.000	.659	.688	.750	.811	.000	.794	.750	.918	.825	.000	.917	.857

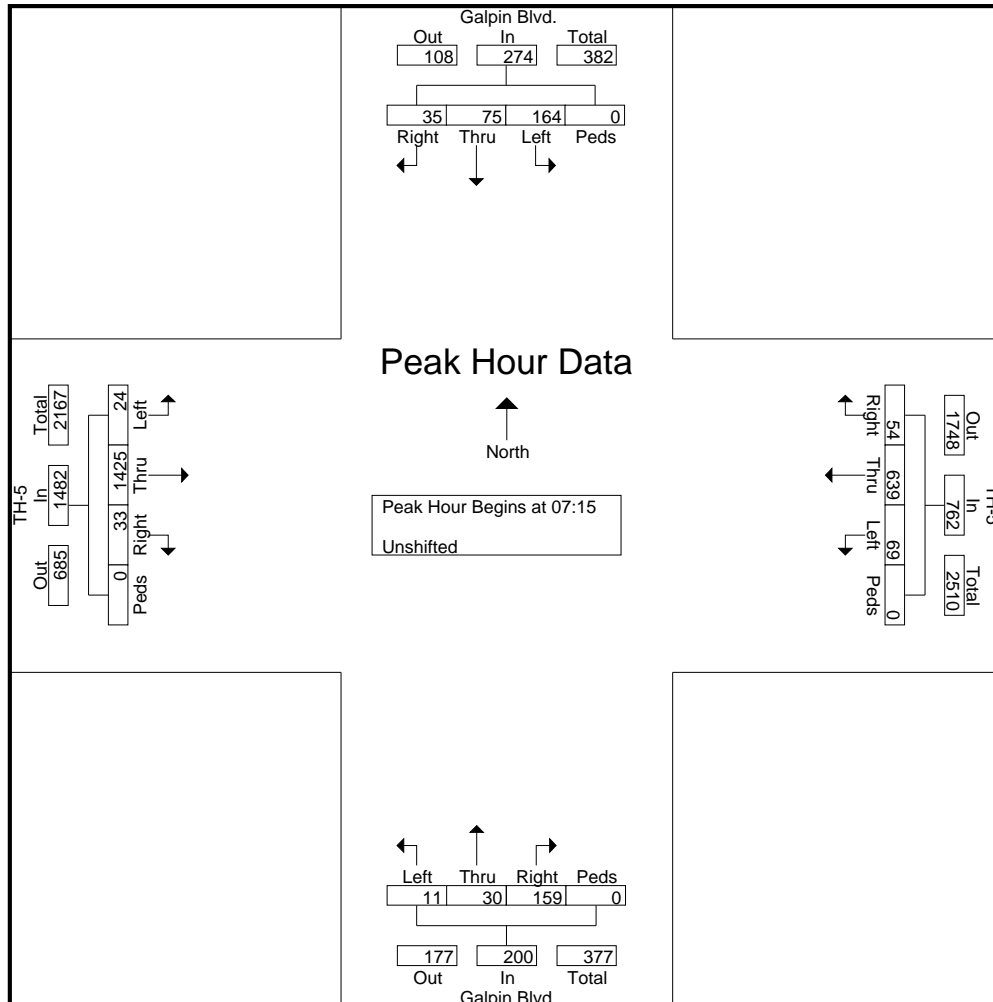



# MINNESOTA DEPT OF TRANSPORTATION

TRAFFIC DATA COLLECTION - METRO

TH-5 at Galpin Blvd. CHANHASSEN  
 Ref.Pt.: 043.274  
 Data by: Westwood Professional Services  
 TURN MOVEMENT COUNT

File Name : TH-5 at Galpin Blvd 2008 CHANHASSEN  
 Site Code : 07052523  
 Start Date : 9/23/2008  
 Page No : 3

Start Time	Galpin Blvd. Southbound					TH-5 Westbound					Galpin Blvd. Northbound					TH-5 Eastbound					Int. Total
	Left	Thru	Right	Peds	App. Total	Left	Thru	Right	Peds	App. Total	Left	Thru	Right	Peds	App. Total	Left	Thru	Right	Peds	App. Total	

Peak Hour Analysis From 15:00 to 17:45 - Peak 1 of 1

Peak Hour for Entire Intersection Begins at 16:45

16:45	10	15	11	0	36	19	310	35	0	364	6	15	25	0	46	5	212	10	0	227	673
17:00	11	23	15	0	49	24	270	48	0	342	10	22	29	0	61	9	202	2	0	213	665
17:15	22	18	17	0	57	23	273	48	0	344	8	14	9	0	31	10	208	11	0	229	661
17:30	6	7	9	0	22	17	334	42	0	393	6	17	22	0	45	9	183	6	0	198	658
Total Volume	49	63	52	0	164	83	1187	173	0	1443	30	68	85	0	183	33	805	29	0	867	2657
% App. Total	29.9	38.4	31.7	0		5.8	82.3	12	0		16.4	37.2	46.4	0		3.8	92.8	3.3	0		
PHF	.557	.685	.765	.000	.719	.865	.888	.901	.000	.918	.750	.773	.733	.000	.750	.825	.949	.659	.000	.947	.987

