



# MINNESOTA DEPT OF TRANSPORTATION

## TRAFFIC DATA COLLECTION - METRO

TH-5 AT CHERRY ST AND 10TH ST WACONIA File Name : TH 5 AT CHERRY ST AND 10TH ST 2008

Ref.Pt.: 031.711

Site Code : 00000000

JAMAR# 632 DR

Start Date : 6/18/2008

TURN MOVEMENT COUNT

Page No : 1

### Groups Printed- Unshifted

| Start Time    | CHERRY ST Southbound |      |       |      | TH 5 Westbound |      |       |      | TENTH ST Northbound |      |       |      | TH 5 Eastbound |      |       |      | Int. Total |
|---------------|----------------------|------|-------|------|----------------|------|-------|------|---------------------|------|-------|------|----------------|------|-------|------|------------|
|               | Left                 | Thru | Right | Peds | Left           | Thru | Right | Peds | Left                | Thru | Right | Peds | Left           | Thru | Right | Peds |            |
| 06:00         | 0                    | 0    | 8     | 0    | 0              | 40   | 13    | 0    | 0                   | 0    | 1     | 0    | 16             | 196  | 3     | 0    | 277        |
| 06:15         | 0                    | 0    | 2     | 0    | 0              | 50   | 14    | 0    | 0                   | 0    | 0     | 0    | 25             | 224  | 9     | 0    | 324        |
| 06:30         | 0                    | 0    | 5     | 0    | 0              | 57   | 12    | 0    | 0                   | 0    | 0     | 0    | 20             | 210  | 24    | 0    | 328        |
| 06:45         | 0                    | 0    | 6     | 0    | 0              | 84   | 26    | 0    | 0                   | 0    | 2     | 0    | 60             | 226  | 28    | 0    | 432        |
| Total         | 0                    | 0    | 21    | 0    | 0              | 231  | 65    | 0    | 0                   | 0    | 3     | 0    | 121            | 856  | 64    | 0    | 1361       |
| 07:00         | 2                    | 0    | 9     | 0    | 0              | 68   | 9     | 0    | 0                   | 0    | 2     | 0    | 18             | 234  | 20    | 0    | 362        |
| 07:15         | 1                    | 0    | 9     | 0    | 0              | 85   | 12    | 0    | 0                   | 0    | 2     | 0    | 24             | 217  | 19    | 0    | 369        |
| 07:30         | 2                    | 0    | 11    | 0    | 0              | 107  | 12    | 0    | 0                   | 0    | 2     | 0    | 45             | 215  | 28    | 0    | 422        |
| 07:45         | 2                    | 0    | 6     | 0    | 0              | 103  | 15    | 0    | 0                   | 0    | 0     | 0    | 39             | 257  | 41    | 0    | 463        |
| Total         | 7                    | 0    | 35    | 0    | 0              | 363  | 48    | 0    | 0                   | 0    | 6     | 0    | 126            | 923  | 108   | 0    | 1616       |
| 08:00         | 3                    | 0    | 4     | 0    | 0              | 89   | 21    | 0    | 0                   | 0    | 0     | 0    | 38             | 168  | 11    | 0    | 334        |
| 08:15         | 2                    | 0    | 5     | 0    | 0              | 71   | 19    | 0    | 0                   | 0    | 3     | 0    | 18             | 156  | 5     | 0    | 279        |
| 08:30         | 7                    | 0    | 10    | 0    | 0              | 108  | 14    | 0    | 0                   | 0    | 1     | 0    | 33             | 192  | 4     | 0    | 369        |
| 08:45         | 3                    | 0    | 8     | 0    | 0              | 109  | 25    | 0    | 0                   | 0    | 1     | 0    | 35             | 144  | 4     | 0    | 329        |
| Total         | 15                   | 0    | 27    | 0    | 0              | 377  | 79    | 0    | 0                   | 0    | 5     | 0    | 124            | 660  | 24    | 0    | 1311       |
| *** BREAK *** |                      |      |       |      |                |      |       |      |                     |      |       |      |                |      |       |      |            |
| 14:45         | 9                    | 0    | 16    | 0    | 0              | 160  | 20    | 0    | 0                   | 0    | 1     | 0    | 34             | 111  | 3     | 0    | 354        |
| Total         | 9                    | 0    | 16    | 0    | 0              | 160  | 20    | 0    | 0                   | 0    | 1     | 0    | 34             | 111  | 3     | 0    | 354        |
| 15:00         | 11                   | 0    | 34    | 0    | 1              | 178  | 11    | 0    | 0                   | 1    | 0     | 0    | 13             | 122  | 7     | 0    | 378        |
| 15:15         | 19                   | 0    | 31    | 0    | 0              | 192  | 16    | 0    | 0                   | 0    | 1     | 0    | 13             | 130  | 3     | 0    | 405        |
| 15:30         | 11                   | 0    | 50    | 0    | 0              | 224  | 17    | 0    | 0                   | 0    | 1     | 0    | 6              | 130  | 4     | 0    | 443        |
| 15:45         | 7                    | 0    | 27    | 0    | 0              | 223  | 12    | 0    | 0                   | 0    | 1     | 0    | 15             | 108  | 4     | 0    | 397        |
| Total         | 48                   | 0    | 142   | 0    | 1              | 817  | 56    | 0    | 0                   | 1    | 3     | 0    | 47             | 490  | 18    | 0    | 1623       |
| 16:00         | 5                    | 0    | 41    | 0    | 0              | 232  | 11    | 0    | 0                   | 0    | 1     | 0    | 18             | 121  | 4     | 0    | 433        |
| 16:15         | 9                    | 0    | 26    | 0    | 0              | 209  | 16    | 0    | 0                   | 0    | 1     | 0    | 13             | 129  | 7     | 0    | 410        |
| 16:30         | 6                    | 0    | 41    | 0    | 0              | 225  | 8     | 0    | 0                   | 0    | 4     | 0    | 15             | 136  | 2     | 0    | 437        |
| 16:45         | 5                    | 0    | 45    | 0    | 0              | 236  | 4     | 0    | 0                   | 0    | 2     | 0    | 4              | 124  | 5     | 0    | 425        |
| Total         | 25                   | 0    | 153   | 0    | 0              | 902  | 39    | 0    | 0                   | 0    | 8     | 0    | 50             | 510  | 18    | 0    | 1705       |
| 17:00         | 14                   | 0    | 33    | 0    | 0              | 236  | 6     | 0    | 0                   | 0    | 4     | 0    | 8              | 147  | 5     | 0    | 453        |
| 17:15         | 13                   | 0    | 31    | 0    | 0              | 220  | 2     | 0    | 0                   | 0    | 2     | 0    | 6              | 159  | 8     | 0    | 441        |
| 17:30         | 4                    | 0    | 34    | 0    | 0              | 245  | 2     | 0    | 0                   | 0    | 3     | 0    | 9              | 149  | 4     | 0    | 450        |
| 17:45         | 3                    | 0    | 15    | 0    | 0              | 243  | 8     | 0    | 0                   | 0    | 1     | 0    | 20             | 163  | 0     | 0    | 453        |
| Total         | 34                   | 0    | 113   | 0    | 0              | 944  | 18    | 0    | 0                   | 0    | 10    | 0    | 43             | 618  | 17    | 0    | 1797       |
| Grand Total   | 138                  | 0    | 507   | 0    | 1              | 3794 | 325   | 0    | 0                   | 1    | 36    | 0    | 545            | 4168 | 252   | 0    | 9767       |
| Apprch %      | 21.4                 | 0    | 78.6  | 0    | 0              | 92.1 | 7.9   | 0    | 0                   | 2.7  | 97.3  | 0    | 11             | 83.9 | 5.1   | 0    |            |
| Total %       | 1.4                  | 0    | 5.2   | 0    | 0              | 38.8 | 3.3   | 0    | 0                   | 0    | 0.4   | 0    | 5.6            | 42.7 | 2.6   | 0    |            |



# MINNESOTA DEPT OF TRANSPORTATION

TRAFFIC DATA COLLECTION - METRO

TH-5 AT CHERRY ST AND 10TH ST WACONIA File Name : TH 5 AT CHERRY ST AND 10TH ST 2008  
 Ref.Pt.: 031.711 Site Code : 00000000  
 JAMAR# 632 DR Start Date : 6/18/2008  
 TURN MOVEMENT COUNT Page No : 2

| Start Time  | CHERRY ST Southbound |      |       |      |            | TH 5 Westbound |      |       |      |            | TENTH ST Northbound |      |       |      |            | TH 5 Eastbound |      |       |      |            | Int. Total |
|---|----------------------|------|-------|------|------------|----------------|------|-------|------|------------|---------------------|------|-------|------|------------|----------------|------|-------|------|------------|------------|
|   | Left                 | Thru | Right | Peds | App. Total | Left           | Thru | Right | Peds | App. Total | Left                | Thru | Right | Peds | App. Total | Left           | Thru | Right | Peds | App. Total |            |
| <b>Peak Hour Analysis From 06:00 to 09:45 - Peak 1 of 1</b> |                      |      |       |      |            |                |      |       |      |            |                     |      |       |      |            |                |      |       |      |            |            |
| Peak Hour for Entire Intersection Begins at 07:00           |                      |      |       |      |            |                |      |       |      |            |                     |      |       |      |            |                |      |       |      |            |            |
| 07:00   | 2                    | 0    | 9     | 0    | 11         | 0              | 68   | 9     | 0    | 77         | 0                   | 0    | 2     | 0    | 2          | 18             | 234  | 20    | 0    | 272        | 362        |
| 07:15   | 1                    | 0    | 9     | 0    | 10         | 0              | 85   | 12    | 0    | 97         | 0                   | 0    | 2     | 0    | 2          | 24             | 217  | 19    | 0    | 260        | 369        |
| 07:30   | 2                    | 0    | 11    | 0    | 13         | 0              | 107  | 12    | 0    | 119        | 0                   | 0    | 2     | 0    | 2          | 45             | 215  | 28    | 0    | 288        | 422        |
| 07:45   | 2                    | 0    | 6     | 0    | 8          | 0              | 103  | 15    | 0    | 118        | 0                   | 0    | 0     | 0    | 0          | 39             | 257  | 41    | 0    | 337        | 463        |
| Total Volume  | 7                    | 0    | 35    | 0    | 42         | 0              | 363  | 48    | 0    | 411        | 0                   | 0    | 6     | 0    | 6          | 126            | 923  | 108   | 0    | 1157       | 1616       |
| % App. Total  |                      |      |       |      |            |                |      |       |      |            |                     |      |       |      |            |                |      |       |      |            |            |
| PHF   | .875                 | .000 | .795  | .000 | .808       | .000           | .848 | .800  | .000 | .863       | .000                | .000 | .750  | .000 | .750       | .700           | .898 | .659  | .000 | .858       | .873       |

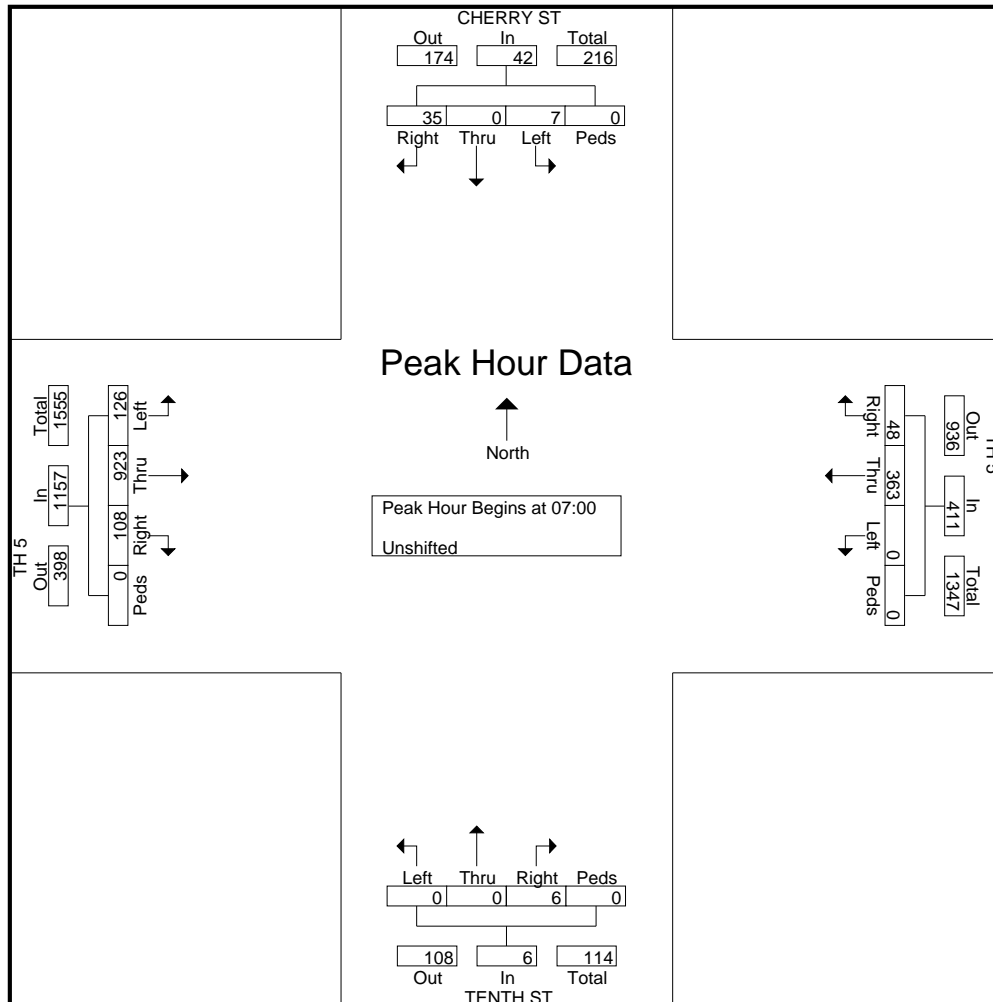



# MINNESOTA DEPT OF TRANSPORTATION

TRAFFIC DATA COLLECTION - METRO

TH-5 AT CHERRY ST AND 10TH ST WACONIA File Name : TH 5 AT CHERRY ST AND 10TH ST 2008  
 Ref.Pt.: 031.711 Site Code : 00000000  
 JAMAR# 632 DR Start Date : 6/18/2008  
 TURN MOVEMENT COUNT Page No : 3

| Start Time   | CHERRY ST Southbound |      |       |      |            | TH 5 Westbound |      |       |      |            | TENTH ST Northbound |      |       |      |            | TH 5 Eastbound |      |       |      |            | Int. Total |
|--|----------------------|------|-------|------|------------|----------------|------|-------|------|------------|---------------------|------|-------|------|------------|----------------|------|-------|------|------------|------------|
|  | Left                 | Thru | Right | Peds | App. Total | Left           | Thru | Right | Peds | App. Total | Left                | Thru | Right | Peds | App. Total | Left           | Thru | Right | Peds | App. Total |            |
| Peak Hour Analysis From 15:00 to 17:45 - Peak 1 of 1 |                      |      |       |      |            |                |      |       |      |            |                     |      |       |      |            |                |      |       |      |            |            |
| Peak Hour for Entire Intersection Begins at 17:00    |                      |      |       |      |            |                |      |       |      |            |                     |      |       |      |            |                |      |       |      |            |            |
| 17:00  | 14                   | 0    | 33    | 0    | 47         | 0              | 236  | 6     | 0    | 242        | 0                   | 0    | 4     | 0    | 4          | 8              | 147  | 5     | 0    | 160        | 453        |
| 17:15  | 13                   | 0    | 31    | 0    | 44         | 0              | 220  | 2     | 0    | 222        | 0                   | 0    | 2     | 0    | 2          | 6              | 159  | 8     | 0    | 173        | 441        |
| 17:30  | 4                    | 0    | 34    | 0    | 38         | 0              | 245  | 2     | 0    | 247        | 0                   | 0    | 3     | 0    | 3          | 9              | 149  | 4     | 0    | 162        | 450        |
| 17:45  | 3                    | 0    | 15    | 0    | 18         | 0              | 243  | 8     | 0    | 251        | 0                   | 0    | 1     | 0    | 1          | 20             | 163  | 0     | 0    | 183        | 453        |
| Total Volume   | 34                   | 0    | 113   | 0    | 147        | 0              | 944  | 18    | 0    | 962        | 0                   | 0    | 10    | 0    | 10         | 43             | 618  | 17    | 0    | 678        | 1797       |
| % App. Total   |                      |      |       |      |            |                |      |       |      |            |                     |      |       |      |            |                |      |       |      |            |            |
| PHF  | .607                 | .000 | .831  | .000 | .782       | .000           | .963 | .563  | .000 | .958       | .000                | .000 | .625  | .000 | .625       | .538           | .948 | .531  | .000 | .926       | .992       |

