



# MINNESOTA DEPT OF TRANSPORTATION

## TRAFFIC DATA COLLECTION - METRO

Location: TH-5 AT CHERRY ST. WACONIA

Ref.Pt.: 031.711

JAMAR# 632 DR

TURN MOVEMENT COUNT

File Name : TH 5 AT CHERRY AND TENTH ST 2008

Site Code : 00000000

Start Date : 11/19/2008

Page No : 1

Groups Printed- Unshifted

Start Time	CHERRY ST Southbound				TH 5 Westbound				TENTH ST Northbound				TH 5 Eastbound				Int. Total
	Left	Thru	Right	Peds	Left	Thru	Right	Peds	Left	Thru	Right	Peds	Left	Thru	Right	Peds	
06:00	1	0	0	0	0	15	10	0	0	0	0	0	16	79	2	0	123
06:15	1	0	5	0	0	33	22	0	0	0	0	0	24	106	3	0	194
06:30	0	0	3	0	0	38	19	0	0	0	2	0	30	109	6	0	207
06:45	0	0	3	0	0	57	17	0	0	0	0	0	53	129	5	0	264
Total	2	0	11	0	0	143	68	0	0	0	2	0	123	423	16	0	788
07:00	2	0	6	0	0	58	8	0	0	0	1	0	13	143	6	0	237
07:15	2	0	7	0	0	83	15	0	0	0	0	0	35	139	14	0	295
07:30	2	0	9	0	0	114	18	0	0	0	0	0	27	196	18	0	384
07:45	2	0	10	0	0	110	21	0	0	0	0	0	52	202	16	0	413
Total	8	0	32	0	0	365	62	0	0	0	1	0	127	680	54	0	1329
08:00	2	0	9	0	0	90	11	0	0	0	0	0	30	148	5	0	295
08:15	3	0	9	0	0	68	12	0	0	0	0	0	42	107	4	0	245
08:30	6	0	12	0	0	80	18	0	0	0	1	0	42	120	4	0	283
08:45	7	0	5	0	0	58	23	0	0	0	0	0	37	80	3	0	213
Total	18	0	35	0	0	296	64	0	0	0	1	0	151	455	16	0	1036
*** BREAK ***																	
15:00	12	0	32	0	0	168	8	0	0	0	0	0	31	147	3	0	401
15:15	36	0	37	0	0	145	16	0	0	0	1	0	24	106	9	0	374
15:30	10	0	46	0	0	149	18	0	0	0	5	0	21	93	6	0	348
15:45	10	0	35	0	0	132	11	0	0	0	0	0	18	101	0	0	307
Total	68	0	150	0	0	594	53	0	0	0	6	0	94	447	18	0	1430
16:00	6	0	36	0	0	166	10	0	0	0	2	0	20	118	2	0	360
16:15	8	0	39	0	0	155	13	0	0	0	3	0	22	89	0	0	329
16:30	16	0	45	0	0	178	11	0	0	0	2	0	12	103	2	0	369
16:45	2	0	40	0	0	178	9	0	0	0	0	0	14	105	3	0	351
Total	32	0	160	0	0	677	43	0	0	0	7	0	68	415	7	0	1409
17:00	3	0	38	0	0	181	9	0	0	0	2	0	14	126	0	0	373
17:15	13	0	43	0	0	168	2	0	0	0	1	0	13	108	5	0	353
17:30	2	0	29	0	0	189	5	0	0	0	2	0	13	113	2	0	355
17:45	5	0	26	0	0	166	6	0	0	0	1	0	16	99	2	0	321
Total	23	0	136	0	0	704	22	0	0	0	6	0	56	446	9	0	1402
Grand Total	151	0	524	0	0	2779	312	0	0	0	23	0	619	2866	120	0	7394
Apprch %	22.4	0	77.6	0	0	89.9	10.1	0	0	0	100	0	17.2	79.5	3.3	0	
Total %	2	0	7.1	0	0	37.6	4.2	0	0	0	0.3	0	8.4	38.8	1.6	0	



# MINNESOTA DEPT OF TRANSPORTATION

TRAFFIC DATA COLLECTION - METRO

Location: TH-5 AT CHERRY ST. WACONIA  
 Ref.Pt.: 031.711  
 JAMAR# 632 DR  
 TURN MOVEMENT COUNT

File Name : TH 5 AT CHERRY AND TENTH ST 2008  
 Site Code : 00000000  
 Start Date : 11/19/2008  
 Page No : 2

Start Time	CHERRY ST Southbound					TH 5 Westbound					TENTH ST Northbound					TH 5 Eastbound					Int. Total
	Left	Thru	Right	Peds	App. Total	Left	Thru	Right	Peds	App. Total	Left	Thru	Right	Peds	App. Total	Left	Thru	Right	Peds	App. Total	
<b>Peak Hour Analysis From 06:00 to 08:45 - Peak 1 of 1</b>																					
Peak Hour for Entire Intersection Begins at 07:15																					
07:15	2	0	7	0	9	0	83	15	0	98	0	0	0	0	0	35	139	14	0	188	295
07:30	2	0	9	0	11	0	114	18	0	132	0	0	0	0	0	27	196	18	0	241	384
07:45	2	0	10	0	12	0	110	21	0	131	0	0	0	0	0	52	202	16	0	270	413
08:00	2	0	9	0	11	0	90	11	0	101	0	0	0	0	0	30	148	5	0	183	295
Total Volume	8	0	35	0	43	0	397	65	0	462	0	0	0	0	0	144	685	53	0	882	1387
% App. Total																					
PHF	1.000	.000	.875	.000	.896	.000	.871	.774	.000	.875	.000	.000	.000	.000	.000	.692	.848	.736	.000	.817	.840

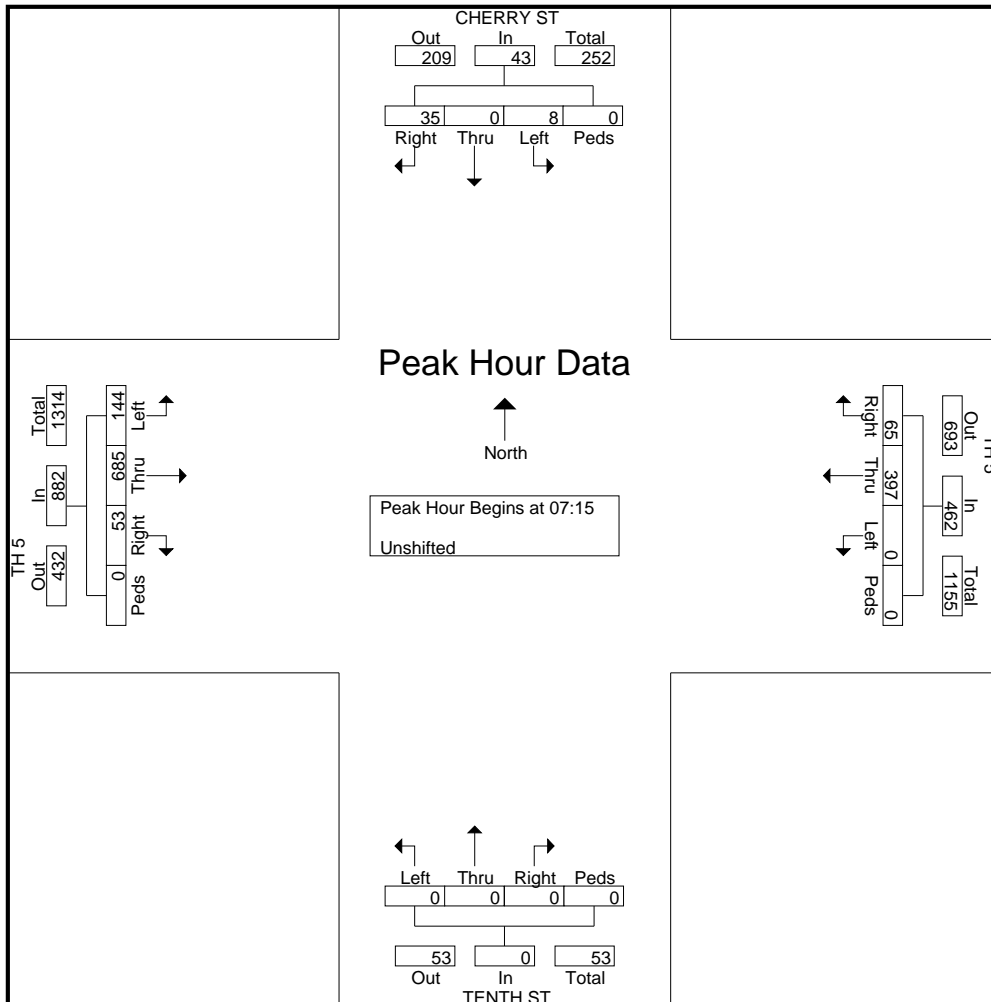



# MINNESOTA DEPT OF TRANSPORTATION

TRAFFIC DATA COLLECTION - METRO

Location: TH-5 AT CHERRY ST. WACONIA  
 Ref.Pt.: 031.711  
 JAMAR# 632 DR  
 TURN MOVEMENT COUNT

File Name : TH 5 AT CHERRY AND TENTH ST 2008  
 Site Code : 00000000  
 Start Date : 11/19/2008  
 Page No : 3

Start Time	CHERRY ST Southbound					TH 5 Westbound					TENTH ST Northbound					TH 5 Eastbound					Int. Total
	Left	Thru	Right	Peds	App. Total	Left	Thru	Right	Peds	App. Total	Left	Thru	Right	Peds	App. Total	Left	Thru	Right	Peds	App. Total	
Peak Hour Analysis From 15:00 to 17:45 - Peak 1 of 1																					
Peak Hour for Entire Intersection Begins at 16:30																					
16:30	16	0	45	0	61	0	178	11	0	189	0	0	2	0	2	12	103	2	0	117	369
16:45	2	0	40	0	42	0	178	9	0	187	0	0	0	0	0	14	105	3	0	122	351
17:00	3	0	38	0	41	0	181	9	0	190	0	0	2	0	2	14	126	0	0	140	373
17:15	13	0	43	0	56	0	168	2	0	170	0	0	1	0	1	13	108	5	0	126	353
Total Volume	34	0	166	0	200	0	705	31	0	736	0	0	5	0	5	53	442	10	0	505	1446
% App. Total																					
PHF	.531	.000	.922	.000	.820	.000	.974	.705	.000	.968	.000	.000	.625	.000	.625	.946	.877	.500	.000	.902	.969

