



MINNESOTA DEPT OF TRANSPORTATION

TRAFFIC DATA COLLECTION - METRO

TH-41 at Engler Blvd / CSAH-10
 Ref.Pt.: 003.113
 Data by: Westwood Professional Services
 TURN MOVEMENT COUNT

File Name : TH-41 at Engler Blvd 2008
 Site Code : 26053428
 Start Date : 10/28/2008
 Page No : 1

Groups Printed- Unshifted

Start Time	TH-41 Southbound				Engler Blvd. / CSAH-10 Westbound				TH-41 Northbound				Engler Blvd. / CSAH-10 Eastbound				Int. Total
	Left	Thru	Right	Peds	Left	Thru	Right	Peds	Left	Thru	Right	Peds	Left	Thru	Right	Peds	
06:00	2	26	9	0	4	12	12	1	5	71	3	0	32	24	8	0	209
06:15	8	26	4	0	2	20	21	0	12	104	3	0	34	37	16	0	287
06:30	11	53	10	0	7	25	32	0	18	125	5	0	35	45	14	0	380
06:45	16	53	10	0	7	23	30	0	27	142	15	0	40	83	23	0	469
Total	37	158	33	0	20	80	95	1	62	442	26	0	141	189	61	0	1345
07:00	15	53	12	0	13	30	43	0	26	139	33	0	49	108	13	0	534
07:15	29	69	14	0	17	42	54	0	26	170	16	0	32	107	20	0	596
07:30	11	99	13	0	5	34	27	0	25	158	9	0	48	75	42	0	546
07:45	17	88	14	0	5	24	31	0	29	209	9	0	63	114	32	0	635
Total	72	309	53	0	40	130	155	0	106	676	67	0	192	404	107	0	2311
08:00	12	94	13	2	5	28	16	0	19	154	8	0	41	51	24	0	467
08:15	11	103	21	0	3	23	32	0	19	139	5	0	30	41	27	0	454
08:30	10	86	24	0	4	20	21	0	29	103	5	0	40	56	24	0	422
08:45	13	86	21	0	7	21	22	0	24	130	4	0	36	36	30	0	430
Total	46	369	79	2	19	92	91	0	91	526	22	0	147	184	105	0	1773
*** BREAK ***																	
11:00	10	85	19	0	4	20	17	1	25	107	6	0	11	21	27	0	353
11:15	26	104	23	0	8	23	14	0	34	110	7	0	24	25	22	0	420
11:30	21	111	13	0	6	37	25	0	28	134	7	0	23	17	25	0	447
11:45	7	117	17	0	7	27	16	0	18	118	3	0	18	28	29	0	405
Total	64	417	72	0	25	107	72	1	105	469	23	0	76	91	103	0	1625
12:00	17	104	15	0	5	21	17	0	34	119	5	0	12	20	24	0	393
12:15	16	134	31	0	7	29	21	0	31	120	7	0	20	32	25	0	473
12:30	13	138	16	0	4	14	21	0	33	118	5	0	22	21	18	0	423
12:45	14	129	20	0	3	18	17	0	24	153	12	0	20	23	34	0	467
Total	60	505	82	0	19	82	76	0	122	510	29	0	74	96	101	0	1756
*** BREAK ***																	
15:00	23	126	26	0	16	40	19	0	29	90	10	0	28	26	29	0	462
15:15	26	164	46	0	8	58	15	0	31	97	14	0	26	35	19	0	539
15:30	30	146	43	0	15	62	26	0	61	132	11	0	18	36	35	0	615
15:45	24	144	33	0	8	73	21	0	49	121	11	0	24	55	25	0	588
Total	103	580	148	0	47	233	81	0	170	440	46	0	96	152	108	0	2204
16:00	29	168	42	0	7	54	20	0	35	120	11	0	30	37	22	0	575
16:15	26	150	48	0	11	66	22	0	42	122	14	0	22	41	33	0	597
16:30	23	175	61	0	11	57	23	0	49	167	8	0	27	40	28	0	669
16:45	23	143	40	0	11	76	19	0	51	160	16	0	25	46	38	0	648
Total	101	636	191	0	40	253	84	0	177	569	49	0	104	164	121	0	2489
17:00	26	155	60	0	16	77	19	0	36	154	10	0	32	44	26	0	655
17:15	35	167	36	0	11	60	16	0	46	132	11	0	25	60	31	0	630
17:30	35	146	46	0	10	52	25	0	36	121	6	0	32	38	29	0	576
17:45	27	127	38	0	7	59	29	0	46	100	6	0	15	33	27	0	514
Total	123	595	180	0	44	248	89	0	164	507	33	0	104	175	113	0	2375
Grand Total	606	3569	838	2	254	1225	743	2	997	4139	295	0	934	1455	819	0	15878
Apprch %	12.1	71.2	16.7	0	11.4	55.1	33.4	0.1	18.4	76.2	5.4	0	29.1	45.4	25.5	0	
Total %	3.8	22.5	5.3	0	1.6	7.7	4.7	0	6.3	26.1	1.9	0	5.9	9.2	5.2	0	



MINNESOTA DEPT OF TRANSPORTATION

TRAFFIC DATA COLLECTION - METRO

TH-41 at Engler Blvd / CSAH-10
 Ref.Pt.: 003.113
 Data by: Westwood Professional Services
 TURN MOVEMENT COUNT

File Name : TH-41 at Engler Blvd 2008
 Site Code : 26053428
 Start Date : 10/28/2008
 Page No : 2

Start Time	TH-41 Southbound					Engler Blvd. / CSAH-10 Westbound					TH-41 Northbound					Engler Blvd. / CSAH-10 Eastbound					Int. Total
	Left	Thru	Right	Peds	App. Total	Left	Thru	Right	Peds	App. Total	Left	Thru	Right	Peds	App. Total	Left	Thru	Right	Peds	App. Total	
Peak Hour Analysis From 06:00 to 08:45 - Peak 1 of 1																					
Peak Hour for Entire Intersection Begins at 07:00																					
07:00	15	53	12	0	80	13	30	43	0	86	26	139	33	0	198	49	108	13	0	170	534
07:15	29	69	14	0	112	17	42	54	0	113	26	170	16	0	212	32	107	20	0	159	596
07:30	11	99	13	0	123	5	34	27	0	66	25	158	9	0	192	48	75	42	0	165	546
07:45	17	88	14	0	119	5	24	31	0	60	29	209	9	0	247	63	114	32	0	209	635
Total Volume	72	309	53	0	434	40	130	155	0	325	106	676	67	0	849	192	404	107	0	703	2311
% App. Total	16.6	71.2	12.2	0		12.3	40	47.7	0		12.5	79.6	7.9	0		27.3	57.5	15.2	0		
PHF	.621	.780	.946	.000	.882	.588	.774	.718	.000	.719	.914	.809	.508	.000	.859	.762	.886	.637	.000	.841	.910

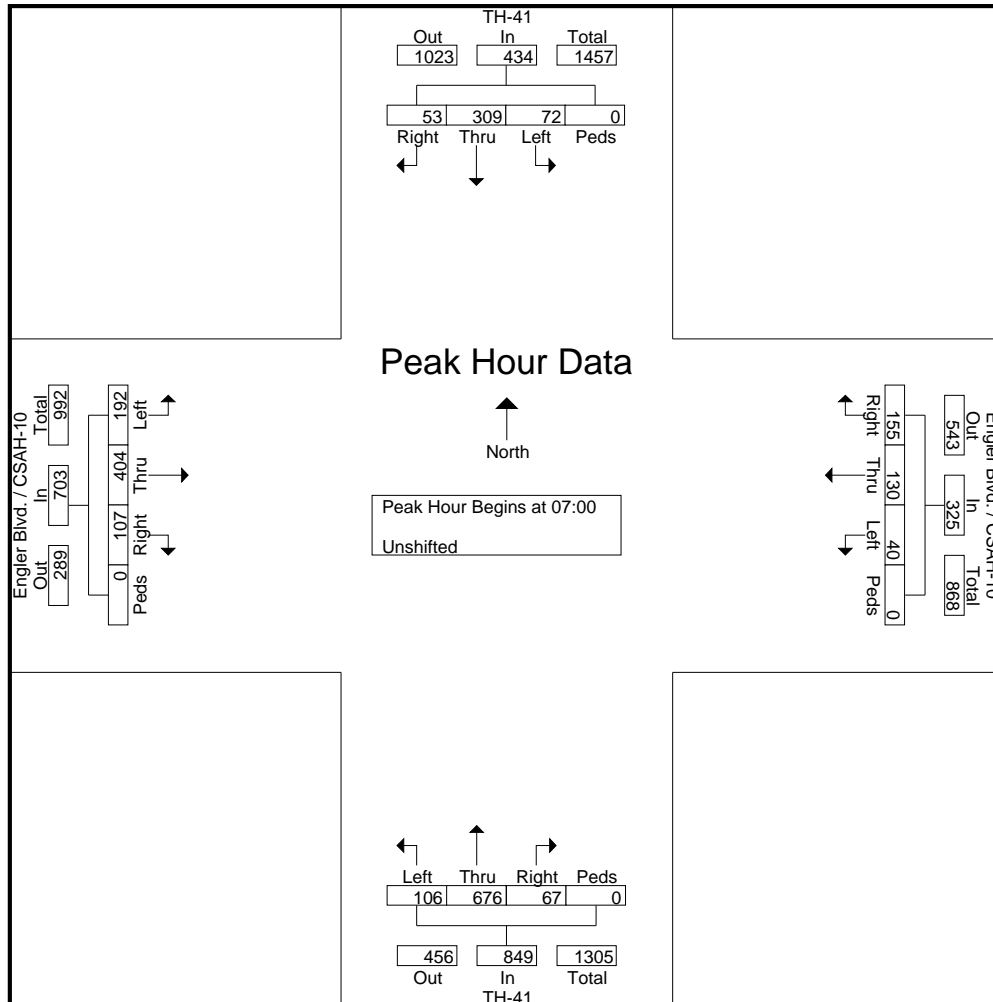



MINNESOTA DEPT OF TRANSPORTATION

TRAFFIC DATA COLLECTION - METRO

TH-41 at Engler Blvd / CSAH-10
 Ref.Pt.: 003.113
 Data by: Westwood Professional Services
 TURN MOVEMENT COUNT

File Name : TH-41 at Engler Blvd 2008
 Site Code : 26053428
 Start Date : 10/28/2008
 Page No : 3

Start Time	TH-41 Southbound					Engler Blvd. / CSAH-10 Westbound					TH-41 Northbound					Engler Blvd. / CSAH-10 Eastbound					Int. Total
	Left	Thru	Right	Peds	App. Total	Left	Thru	Right	Peds	App. Total	Left	Thru	Right	Peds	App. Total	Left	Thru	Right	Peds	App. Total	

Peak Hour Analysis From 15:00 to 17:45 - Peak 1 of 1

Peak Hour for Entire Intersection Begins at 16:30

16:30	23	175	61	0	259	11	57	23	0	91	49	167	8	0	224	27	40	28	0	95	669
16:45	23	143	40	0	206	11	76	19	0	106	51	160	16	0	227	25	46	38	0	109	648
17:00	26	155	60	0	241	16	77	19	0	112	36	154	10	0	200	32	44	26	0	102	655
17:15	35	167	36	0	238	11	60	16	0	87	46	132	11	0	189	25	60	31	0	116	630
Total Volume	107	640	197	0	944	49	270	77	0	396	182	613	45	0	840	109	190	123	0	422	2602
% App. Total	11.3	67.8	20.9	0		12.4	68.2	19.4	0		21.7	73	5.4	0		25.8	45	29.1	0		
PHF	.764	.914	.807	.000	.911	.766	.877	.837	.000	.884	.892	.918	.703	.000	.925	.852	.792	.809	.000	.909	.972

