



# MINNESOTA DEPT OF TRANSPORTATION

## TRAFFIC DATA COLLECTION - METRO

TH-41 at 4th St. CHASKA  
 Ref.Pt.: 001.883  
 Data by: Westwood Professional Services  
 TURN MOVEMENT COUNT

File Name : TH-41 at 4th St CHASKA 2008  
 Site Code : 30052522  
 Start Date : 10/22/2008  
 Page No : 1

**Groups Printed- Unshifted**

Start Time	TH-41 Southbound				4th St. Westbound				TH-41 Northbound				4th St. Eastbound				Int. Total
	Left	Thru	Right	Peds	Left	Thru	Right	Peds	Left	Thru	Right	Peds	Left	Thru	Right	Peds	
06:00	2	78	1	0	1	0	0	0	0	82	8	0	1	0	1	0	174
06:15	1	105	1	0	0	0	2	0	1	102	15	0	2	0	1	0	230
06:30	3	150	1	0	5	0	5	0	0	148	16	0	2	3	2	0	335
06:45	5	126	2	0	2	0	10	0	1	147	16	0	2	3	1	0	315
<b>Total</b>	<b>11</b>	<b>459</b>	<b>5</b>	<b>0</b>	<b>8</b>	<b>0</b>	<b>17</b>	<b>0</b>	<b>2</b>	<b>479</b>	<b>55</b>	<b>0</b>	<b>7</b>	<b>6</b>	<b>5</b>	<b>0</b>	<b>1054</b>
07:00	4	150	3	0	3	1	7	0	0	137	26	0	3	6	2	0	342
07:15	12	146	3	0	10	1	7	0	1	156	33	0	4	3	1	0	377
07:30	17	190	2	0	10	1	9	0	0	170	30	0	8	6	0	0	443
07:45	34	166	3	0	9	1	8	0	2	157	46	0	5	10	2	0	443
<b>Total</b>	<b>67</b>	<b>652</b>	<b>11</b>	<b>0</b>	<b>32</b>	<b>4</b>	<b>31</b>	<b>0</b>	<b>3</b>	<b>620</b>	<b>135</b>	<b>0</b>	<b>20</b>	<b>25</b>	<b>5</b>	<b>0</b>	<b>1605</b>
08:00	17	159	8	0	14	2	9	0	0	141	17	0	5	3	1	0	376
08:15	22	118	2	0	8	0	5	0	0	145	16	0	4	5	1	0	326
08:30	29	147	1	0	8	1	5	0	1	138	14	0	11	7	3	0	365
08:45	15	131	1	0	6	6	11	0	0	127	10	0	1	15	2	0	325
<b>Total</b>	<b>83</b>	<b>555</b>	<b>12</b>	<b>0</b>	<b>36</b>	<b>9</b>	<b>30</b>	<b>0</b>	<b>1</b>	<b>551</b>	<b>57</b>	<b>0</b>	<b>21</b>	<b>30</b>	<b>7</b>	<b>0</b>	<b>1392</b>
*** BREAK ***																	
11:00	9	89	6	0	7	2	23	0	1	101	2	0	8	13	2	0	263
11:15	12	111	4	0	12	3	19	0	0	83	1	0	6	8	4	0	263
11:30	15	114	4	0	15	7	24	0	0	92	9	0	6	9	5	0	300
11:45	13	112	11	0	17	6	8	0	2	91	6	0	8	16	4	0	294
<b>Total</b>	<b>49</b>	<b>426</b>	<b>25</b>	<b>0</b>	<b>51</b>	<b>18</b>	<b>74</b>	<b>0</b>	<b>3</b>	<b>367</b>	<b>18</b>	<b>0</b>	<b>28</b>	<b>46</b>	<b>15</b>	<b>0</b>	<b>1120</b>
12:00	11	114	6	0	7	5	14	0	0	111	15	0	9	12	2	0	306
12:15	15	120	6	0	15	5	23	0	0	105	8	0	11	7	6	0	321
12:30	18	111	9	0	10	4	23	0	2	99	10	0	10	16	3	0	315
12:45	30	99	6	0	13	6	7	0	2	87	14	0	10	15	3	0	292
<b>Total</b>	<b>74</b>	<b>444</b>	<b>27</b>	<b>0</b>	<b>45</b>	<b>20</b>	<b>67</b>	<b>0</b>	<b>4</b>	<b>402</b>	<b>47</b>	<b>0</b>	<b>40</b>	<b>50</b>	<b>14</b>	<b>0</b>	<b>1234</b>
*** BREAK ***																	
15:00	9	136	2	0	14	6	19	0	1	110	4	0	11	8	6	0	326
15:15	16	161	7	0	10	3	16	0	5	124	14	0	13	9	9	0	387
15:30	18	169	8	0	12	10	20	0	0	135	7	0	6	7	3	0	395
15:45	11	165	13	0	21	5	34	0	1	131	6	0	11	18	6	0	422
<b>Total</b>	<b>54</b>	<b>631</b>	<b>30</b>	<b>0</b>	<b>57</b>	<b>24</b>	<b>89</b>	<b>0</b>	<b>7</b>	<b>500</b>	<b>31</b>	<b>0</b>	<b>41</b>	<b>42</b>	<b>24</b>	<b>0</b>	<b>1530</b>
16:00	10	164	2	0	29	11	17	1	3	137	10	0	6	11	7	0	408
16:15	15	197	5	0	15	7	17	0	1	163	9	0	7	9	2	0	447
16:30	9	201	7	0	36	9	33	2	1	155	6	0	10	12	1	0	482
16:45	6	194	8	0	11	7	21	0	3	152	19	0	11	9	5	0	446
<b>Total</b>	<b>40</b>	<b>756</b>	<b>22</b>	<b>0</b>	<b>91</b>	<b>34</b>	<b>88</b>	<b>3</b>	<b>8</b>	<b>607</b>	<b>44</b>	<b>0</b>	<b>34</b>	<b>41</b>	<b>15</b>	<b>0</b>	<b>1783</b>
17:00	11	192	5	0	24	5	14	0	0	191	11	0	13	13	7	0	486
17:15	9	167	8	0	16	5	12	0	1	172	13	0	9	5	3	0	420
17:30	5	160	5	0	15	3	13	0	3	175	8	0	10	6	4	0	407
17:45	9	123	3	0	6	4	5	0	0	169	4	0	10	3	2	0	338
<b>Total</b>	<b>34</b>	<b>642</b>	<b>21</b>	<b>0</b>	<b>61</b>	<b>17</b>	<b>44</b>	<b>0</b>	<b>4</b>	<b>707</b>	<b>36</b>	<b>0</b>	<b>42</b>	<b>27</b>	<b>16</b>	<b>0</b>	<b>1651</b>
<b>Grand Total</b>	<b>412</b>	<b>4565</b>	<b>153</b>	<b>0</b>	<b>381</b>	<b>126</b>	<b>440</b>	<b>3</b>	<b>32</b>	<b>4233</b>	<b>423</b>	<b>0</b>	<b>233</b>	<b>267</b>	<b>101</b>	<b>0</b>	<b>11369</b>
Apprch %	8	89	3	0	40.1	13.3	46.3	0.3	0.7	90.3	9	0	38.8	44.4	16.8	0	
Total %	3.6	40.2	1.3	0	3.4	1.1	3.9	0	0.3	37.2	3.7	0	2	2.3	0.9	0	



# MINNESOTA DEPT OF TRANSPORTATION

TRAFFIC DATA COLLECTION - METRO

TH-41 at 4th St. CHASKA  
 Ref.Pt.: 001.883  
 Data by: Westwood Professional Services  
 TURN MOVEMENT COUNT

File Name : TH-41 at 4th St CHASKA 2008  
 Site Code : 30052522  
 Start Date : 10/22/2008  
 Page No : 2

Start Time	TH-41 Southbound					4th St. Westbound					TH-41 Northbound					4th St. Eastbound					Int. Total
	Left	Thru	Right	Peds	App. Total	Left	Thru	Right	Peds	App. Total	Left	Thru	Right	Peds	App. Total	Left	Thru	Right	Peds	App. Total	
Peak Hour Analysis From 06:00 to 08:45 - Peak 1 of 1																					
Peak Hour for Entire Intersection Begins at 07:15																					
07:15	12	146	3	0	161	10	1	7	0	18	1	156	33	0	190	4	3	1	0	8	377
07:30	17	<b>190</b>	2	0	<b>209</b>	10	1	<b>9</b>	0	20	0	<b>170</b>	30	0	200	<b>8</b>	6	0	0	14	<b>443</b>
07:45	<b>34</b>	166	3	0	203	9	1	8	0	18	<b>2</b>	157	<b>46</b>	0	<b>205</b>	5	<b>10</b>	<b>2</b>	0	<b>17</b>	443
08:00	17	159	<b>8</b>	0	184	<b>14</b>	<b>2</b>	9	0	<b>25</b>	0	141	17	0	158	5	3	1	0	9	376
Total Volume	80	661	16	0	757	43	5	33	0	81	3	624	126	0	753	22	22	4	0	48	1639
% App. Total	10.6	87.3	2.1	0		53.1	6.2	40.7	0		0.4	82.9	16.7	0		45.8	45.8	8.3	0		
PHF	.588	.870	.500	.000	.906	.768	.625	.917	.000	.810	.375	.918	.685	.000	.918	.688	.550	.500	.000	.706	.925

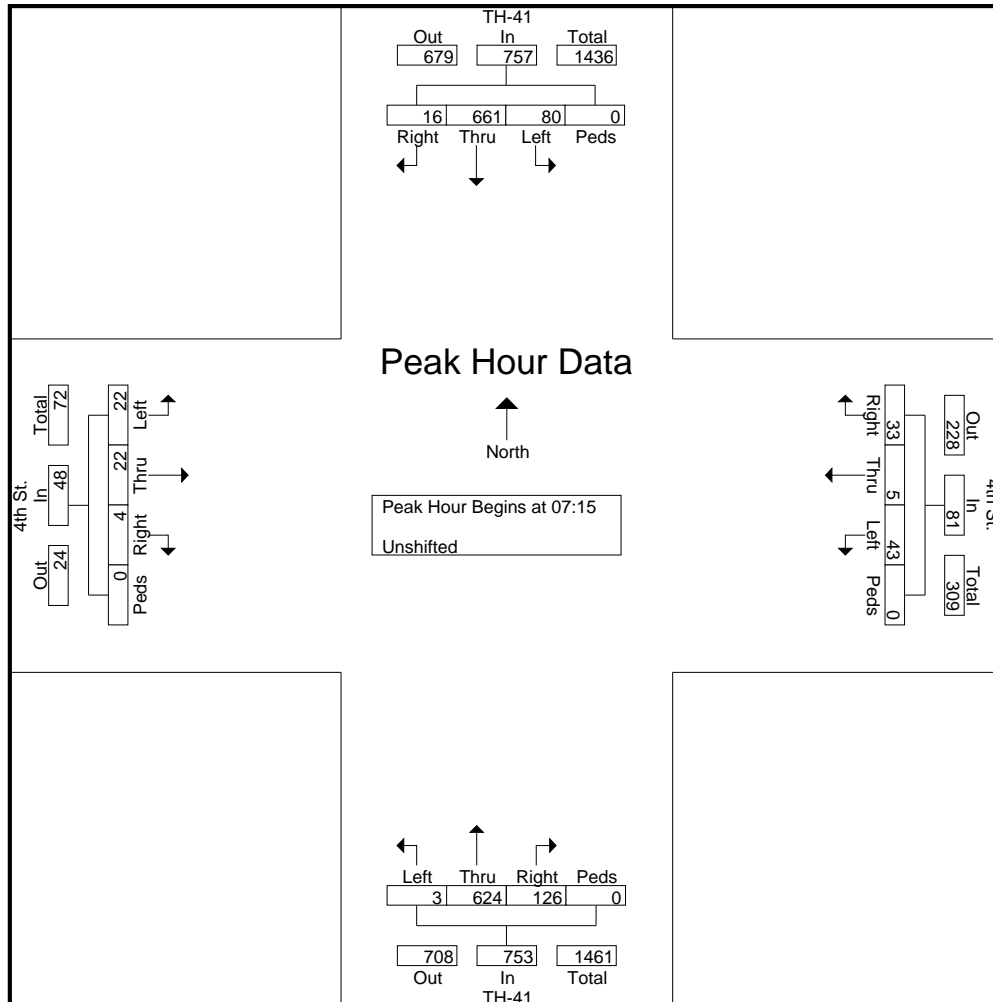



# MINNESOTA DEPT OF TRANSPORTATION

## TRAFFIC DATA COLLECTION - METRO

TH-41 at 4th St. CHASKA  
 Ref.Pt.: 001.883  
 Data by: Westwood Professional Services  
 TURN MOVEMENT COUNT

File Name : TH-41 at 4th St CHASKA 2008  
 Site Code : 30052522  
 Start Date : 10/22/2008  
 Page No : 3

Start Time	TH-41 Southbound					4th St. Westbound					TH-41 Northbound					4th St. Eastbound					Int. Total
	Left	Thru	Right	Peds	App. Total	Left	Thru	Right	Peds	App. Total	Left	Thru	Right	Peds	App. Total	Left	Thru	Right	Peds	App. Total	

Peak Hour Analysis From 15:00 to 17:45 - Peak 1 of 1

Peak Hour for Entire Intersection Begins at 16:15

16:15	15	197	5	0	217	15	7	17	0	39	1	163	9	0	173	7	9	2	0	18	447
16:30	9	201	7	0	217	36	9	33	2	80	1	155	6	0	162	10	12	1	0	23	482
16:45	6	194	8	0	208	11	7	21	0	39	3	152	19	0	174	11	9	5	0	25	446
17:00	11	192	5	0	208	24	5	14	0	43	0	191	11	0	202	13	13	7	0	33	486
Total Volume	41	784	25	0	850	86	28	85	2	201	5	661	45	0	711	41	43	15	0	99	1861
% App. Total	4.8	92.2	2.9	0		42.8	13.9	42.3	1		0.7	93	6.3	0		41.4	43.4	15.2	0		
PHF	.683	.975	.781	.000	.979	.597	.778	.644	.250	.628	.417	.865	.592	.000	.880	.788	.827	.536	.000	.750	.957

