



Minnesota Dept. of Transportation

Traffic Data Collection -Metro

TH-41/ CHESTNUT ST AT 2ND ST
 Ref.Pt; 001.740
 Jamar # T-2638 CAH
 TURN MOVEMENT COUNT

File Name : TH-41-CHESTNUT ST AT 2ND ST
 Site Code : 001.740
 Start Date : 1/29/2013
 Page No : 1

Groups Printed- Unshifted

Start Time	TH 41/ CHESTNUT ST Southbound				2ND ST Westbound				TH 41/ CHESTNUT ST Northbound				2ND ST Eastbound				Int. Total
	Right	Thru	Left	Peds	Right	Thru	Left	Peds	Right	Thru	Left	Peds	Right	Thru	Left	Peds	
06:00	0	60	1	0	5	0	1	0	1	66	6	0	0	0	1	0	141
06:15	0	101	3	0	1	1	6	0	1	93	2	0	0	0	2	0	210
06:30	1	116	2	0	1	0	10	0	4	102	0	0	0	0	4	0	240
06:45	1	128	7	1	5	0	2	2	1	125	2	2	2	0	1	0	279
Total	2	405	13	1	12	1	19	2	7	386	10	2	2	0	8	0	870
07:00	1	137	15	0	3	0	4	0	11	163	5	0	0	0	4	0	343
07:15	2	151	9	0	3	0	9	0	4	185	5	0	1	2	0	0	371
07:30	6	143	17	0	5	0	5	0	6	214	6	0	0	3	1	2	408
07:45	8	133	9	0	3	1	8	0	9	197	11	0	0	0	3	0	382
Total	17	564	50	0	14	1	26	0	30	759	27	0	1	5	8	2	1504
08:00	2	124	5	0	6	2	6	0	5	161	7	0	2	1	2	2	325
08:15	3	113	10	0	0	1	6	0	5	126	8	0	0	0	2	1	275
08:30	2	94	6	0	1	0	7	0	6	119	9	0	1	4	4	0	253
08:45	9	79	8	0	4	2	4	2	9	119	4	0	2	3	4	0	249
Total	16	410	29	0	11	5	23	2	25	525	28	0	5	8	12	3	1102
*** BREAK ***																	
15:00	7	107	8	1	8	1	9	2	2	118	5	2	1	0	2	1	274
15:15	6	129	12	2	7	4	1	0	3	127	12	6	1	0	2	2	314
15:30	8	141	10	0	7	5	8	0	2	140	11	4	0	2	6	0	344
15:45	4	120	8	0	3	4	5	0	2	131	3	2	0	2	6	1	291
Total	25	497	38	3	25	14	23	2	9	516	31	14	2	4	16	4	1223
16:00	3	155	6	1	6	1	8	3	0	112	6	5	2	3	4	0	315
16:15	9	181	3	0	5	3	5	1	2	155	9	0	1	2	5	0	381
16:30	6	165	6	0	3	2	20	0	2	153	9	1	0	0	3	0	370
16:45	11	188	11	0	4	3	8	0	3	184	11	3	1	3	4	0	434
Total	29	689	26	1	18	9	41	4	7	604	35	9	4	8	16	0	1500
17:00	9	184	4	0	4	0	9	0	2	174	10	1	6	1	10	0	414
17:15	10	173	15	0	10	4	7	0	3	175	14	0	2	0	3	0	416
17:30	3	178	10	0	3	2	8	0	3	163	5	0	2	1	1	0	379
17:45	6	136	13	2	11	3	4	0	5	161	9	0	1	1	4	0	356
Total	28	671	42	2	28	9	28	0	13	673	38	1	11	3	18	0	1565
Grand Total	117	3236	198	7	108	39	160	10	91	3463	169	26	25	28	78	9	7764
Apprch %	3.3	90.9	5.6	0.2	34.1	12.3	50.5	3.2	2.4	92.4	4.5	0.7	17.9	20	55.7	6.4	
Total %	1.5	41.7	2.6	0.1	1.4	0.5	2.1	0.1	1.2	44.6	2.2	0.3	0.3	0.4	1	0.1	



Minnesota Dept. of Transportation

Traffic Data Collection -Metro

TH-41/ CHESTNUT ST AT 2ND ST
 Ref.Pt; 001.740
 Jamar # T-2638 CAH
 TURN MOVEMENT COUNT

File Name : TH-41-CHESTNUT ST AT 2ND ST
 Site Code : 001.740
 Start Date : 1/29/2013
 Page No : 2

Start Time	TH 41/ CHESTNUT ST Southbound					2ND ST Westbound					TH 41/ CHESTNUT ST Northbound					2ND ST Eastbound					Int. Total
	Right	Thru	Left	Peds	App. Total	Right	Thru	Left	Peds	App. Total	Right	Thru	Left	Peds	App. Total	Right	Thru	Left	Peds	App. Total	
Peak Hour Analysis From 06:00 to 08:45 - Peak 1 of 1																					
Peak Hour for Entire Intersection Begins at 07:00																					
07:00	1	137	15	0	153	3	0	4	0	7	11	163	5	0	179	0	0	4	0	4	343
07:15	2	151	9	0	162	3	0	9	0	12	4	185	5	0	194	1	2	0	0	3	371
07:30	6	143	17	0	166	5	0	5	0	10	6	214	6	0	226	0	3	1	2	6	408
07:45	8	133	9	0	150	3	1	8	0	12	9	197	11	0	217	0	0	3	0	3	382
Total Volume	17	564	50	0	631	14	1	26	0	41	30	759	27	0	816	1	5	8	2	16	1504
% App. Total	2.7	89.4	7.9	0		34.1	2.4	63.4	0		3.7	93	3.3	0		6.2	31.2	50	12.5		
PHF	.531	.934	.735	.000	.950	.700	.250	.722	.000	.854	.682	.887	.614	.000	.903	.250	.417	.500	.250	.667	.922

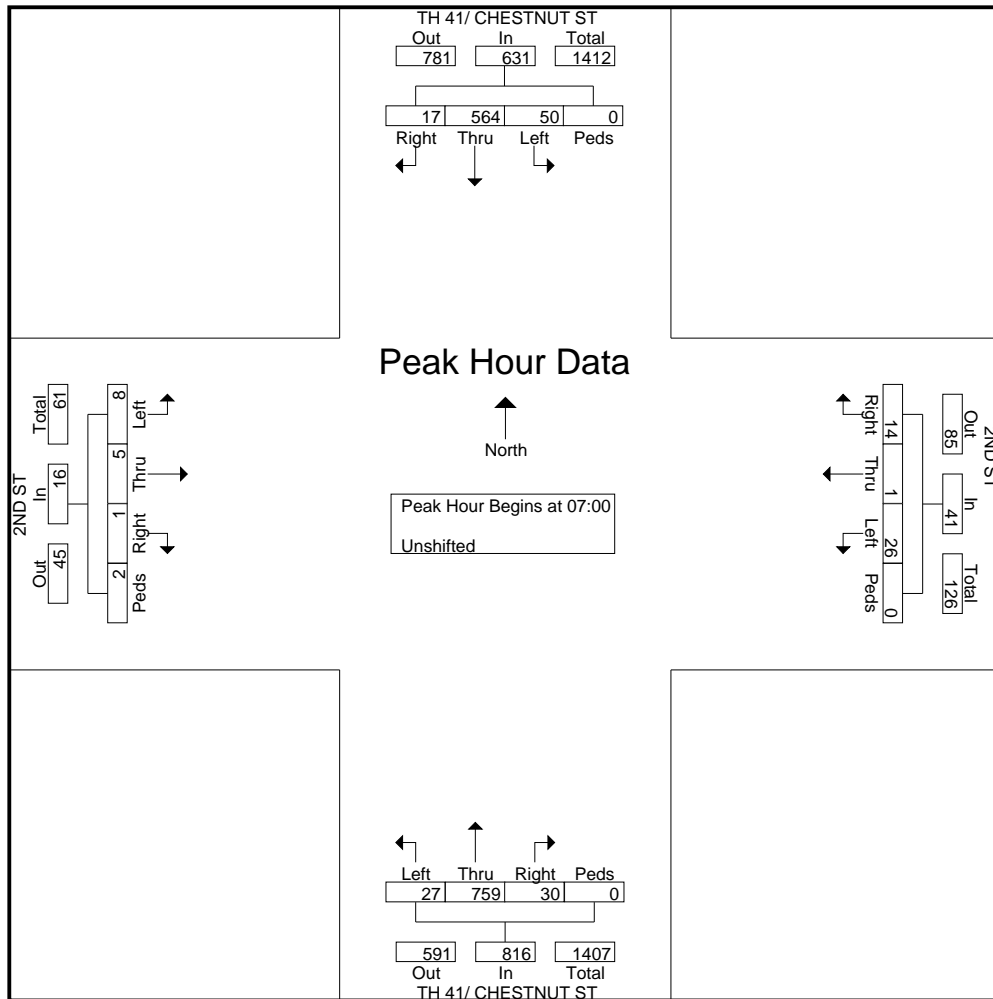



Minnesota Dept. of Transportation

Traffic Data Collection -Metro

TH-41/ CHESTNUT ST AT 2ND ST
 Ref.Pt; 001.740
 Jamar # T-2638 CAH
 TURN MOVEMENT COUNT

File Name : TH-41-CHESTNUT ST AT 2ND ST
 Site Code : 001.740
 Start Date : 1/29/2013
 Page No : 3

Start Time	TH 41/ CHESTNUT ST Southbound					2ND ST Westbound					TH 41/ CHESTNUT ST Northbound					2ND ST Eastbound					Int. Total
	Rig ht	Thr u	Left	Ped s	App. Total	Rig ht	Thr u	Left	Ped s	App. Total	Right	Thr u	Left	Peds	App. Total	Right	Thr u	Left	Peds	App. Total	
Peak Hour Analysis From 15:00 to 17:45 - Peak 1 of 1																					
Peak Hour for Entire Intersection Begins at 16:45																					
16:45	11	188	11	0	210	4	3	8	0	15	3	184	11	3	201	1	3	4	0	8	434
17:00	9	184	4	0	197	4	0	9	0	13	2	174	10	1	187	6	1	10	0	17	414
17:15	10	173	15	0	198	10	4	7	0	21	3	175	14	0	192	2	0	3	0	5	416
17:30	3	178	10	0	191	3	2	8	0	13	3	163	5	0	171	2	1	1	0	4	379
Total Volume	33	723	40	0	796	21	9	32	0	62	11	696	40	4	751	11	5	18	0	34	1643
% App. Total	4.1	90.8	5	0		33.9	14.5	51.6	0		1.5	92.7	5.3	0.5		32.4	14.7	52.9	0		
PHF	.750	.961	.667	.000	.948	.525	.563	.889	.000	.738	.917	.946	.714	.333	.934	.458	.417	.450	.000	.500	.946

