

MN Dept of Transportation

TRAFFIC DATA COLLECTION - Metro

TH-41 at 2nd Street

CHASKA

File Name : th-41 at 2nd st CHASKA SAT 2015

Ref.Pt.: 001.740

Site Code :

video AL

Start Date : 6/27/2015

TURN MOVEMENT COUNT - Saturday

Page No : 1

Groups Printed- Cars +

| Start Time | TH-41 SB Southbound | | | | 2nd St WB Westbound | | | | TH-41 NB Northbound | | | | 2nd St EB Eastbound | | | | Int. Total |
|------------|---------------------|------|-------|------|---------------------|------|-------|------|---------------------|------|-------|------|---------------------|------|-------|------|------------|
| | Left | Thru | Right | Peds | Left | Thru | Right | Peds | Left | Thru | Right | Peds | Left | Thru | Right | Peds | |
| 06:00 | 1 | 37 | 0 | 0 | 2 | 0 | 3 | 0 | 2 | 35 | 1 | 0 | 1 | 0 | 0 | 0 | 82 |
| 06:15 | 0 | 71 | 0 | 0 | 6 | 0 | 0 | 0 | 0 | 45 | 0 | 0 | 1 | 0 | 0 | 0 | 123 |
| 06:30 | 3 | 55 | 0 | 0 | 1 | 0 | 2 | 0 | 2 | 94 | 0 | 0 | 2 | 0 | 0 | 0 | 159 |
| 06:45 | 6 | 67 | 0 | 0 | 4 | 1 | 3 | 0 | 3 | 95 | 0 | 0 | 1 | 0 | 2 | 0 | 182 |
| Total | 10 | 230 | 0 | 0 | 13 | 1 | 8 | 0 | 7 | 269 | 1 | 0 | 5 | 0 | 2 | 0 | 546 |
| 07:00 | 2 | 83 | 0 | 0 | 3 | 0 | 0 | 0 | 2 | 91 | 1 | 0 | 1 | 0 | 1 | 0 | 184 |
| 07:15 | 3 | 66 | 0 | 0 | 3 | 0 | 5 | 0 | 1 | 98 | 5 | 0 | 0 | 0 | 0 | 1 | 182 |
| 07:30 | 5 | 77 | 1 | 0 | 4 | 0 | 3 | 1 | 3 | 104 | 6 | 0 | 0 | 3 | 0 | 1 | 208 |
| 07:45 | 8 | 105 | 2 | 0 | 5 | 2 | 2 | 1 | 4 | 108 | 0 | 0 | 0 | 0 | 0 | 1 | 238 |
| Total | 18 | 331 | 3 | 0 | 15 | 2 | 10 | 2 | 10 | 401 | 12 | 0 | 1 | 3 | 1 | 3 | 812 |
| 08:00 | 6 | 91 | 0 | 0 | 2 | 1 | 1 | 1 | 4 | 81 | 4 | 0 | 1 | 1 | 0 | 0 | 193 |
| 08:15 | 5 | 109 | 1 | 0 | 5 | 0 | 4 | 2 | 5 | 110 | 0 | 1 | 1 | 0 | 1 | 1 | 245 |
| 08:30 | 9 | 114 | 0 | 3 | 4 | 1 | 3 | 4 | 4 | 136 | 0 | 0 | 5 | 0 | 3 | 1 | 287 |
| 08:45 | 9 | 117 | 2 | 0 | 7 | 1 | 3 | 8 | 5 | 142 | 3 | 2 | 4 | 2 | 0 | 0 | 305 |
| Total | 29 | 431 | 3 | 3 | 18 | 3 | 11 | 15 | 18 | 469 | 7 | 3 | 11 | 3 | 4 | 2 | 1030 |
| 09:00 | 13 | 138 | 4 | 2 | 3 | 0 | 2 | 16 | 3 | 116 | 2 | 0 | 1 | 1 | 0 | 0 | 301 |
| 09:15 | 8 | 176 | 6 | 3 | 2 | 2 | 7 | 8 | 2 | 130 | 2 | 0 | 1 | 3 | 4 | 2 | 356 |
| 09:30 | 16 | 160 | 2 | 1 | 6 | 1 | 5 | 7 | 8 | 152 | 2 | 5 | 3 | 1 | 3 | 4 | 376 |
| 09:45 | 16 | 201 | 2 | 0 | 3 | 1 | 5 | 3 | 2 | 142 | 2 | 10 | 18 | 3 | 2 | 2 | 412 |
| Total | 53 | 675 | 14 | 6 | 14 | 4 | 19 | 34 | 15 | 540 | 8 | 15 | 23 | 8 | 9 | 8 | 1445 |
| 10:00 | 19 | 167 | 2 | 0 | 5 | 2 | 6 | 6 | 7 | 163 | 3 | 3 | 14 | 7 | 3 | 0 | 407 |
| 10:15 | 17 | 168 | 5 | 0 | 7 | 1 | 6 | 15 | 7 | 156 | 7 | 0 | 6 | 3 | 5 | 1 | 404 |
| 10:30 | 14 | 180 | 1 | 0 | 6 | 1 | 9 | 4 | 7 | 162 | 2 | 1 | 21 | 4 | 3 | 0 | 415 |
| 10:45 | 11 | 187 | 2 | 3 | 8 | 2 | 3 | 1 | 1 | 163 | 2 | 0 | 2 | 3 | 5 | 0 | 393 |
| Total | 61 | 702 | 10 | 3 | 26 | 6 | 24 | 26 | 22 | 644 | 14 | 4 | 43 | 17 | 16 | 1 | 1619 |
| 11:00 | 6 | 173 | 3 | 3 | 6 | 3 | 5 | 2 | 6 | 169 | 2 | 0 | 2 | 1 | 1 | 0 | 382 |
| 11:15 | 10 | 162 | 4 | 0 | 10 | 0 | 5 | 10 | 10 | 213 | 1 | 2 | 4 | 3 | 1 | 4 | 439 |
| 11:30 | 8 | 191 | 4 | 1 | 6 | 3 | 9 | 13 | 2 | 161 | 4 | 0 | 1 | 2 | 1 | 1 | 407 |
| 11:45 | 8 | 162 | 2 | 5 | 5 | 0 | 4 | 2 | 7 | 162 | 2 | 5 | 5 | 0 | 2 | 4 | 375 |
| Total | 32 | 688 | 13 | 9 | 27 | 6 | 23 | 27 | 25 | 705 | 9 | 7 | 12 | 6 | 5 | 9 | 1603 |
| 12:00 | 10 | 180 | 1 | 0 | 6 | 2 | 5 | 0 | 9 | 178 | 1 | 0 | 6 | 4 | 5 | 0 | 407 |
| 12:15 | 4 | 177 | 3 | 0 | 2 | 1 | 4 | 0 | 5 | 171 | 3 | 0 | 2 | 0 | 0 | 0 | 372 |
| 12:30 | 5 | 179 | 2 | 0 | 4 | 2 | 4 | 0 | 9 | 173 | 1 | 0 | 1 | 0 | 0 | 0 | 380 |
| 12:45 | 9 | 171 | 2 | 0 | 3 | 2 | 6 | 0 | 6 | 159 | 6 | 0 | 3 | 1 | 2 | 0 | 370 |
| Total | 28 | 707 | 8 | 0 | 15 | 7 | 19 | 0 | 29 | 681 | 11 | 0 | 12 | 5 | 7 | 0 | 1529 |
| 13:00 | 12 | 172 | 4 | 0 | 6 | 0 | 2 | 0 | 4 | 169 | 2 | 0 | 3 | 0 | 2 | 0 | 376 |
| 13:15 | 5 | 208 | 4 | 0 | 7 | 3 | 10 | 0 | 10 | 163 | 1 | 0 | 3 | 1 | 1 | 0 | 416 |
| 13:30 | 3 | 175 | 2 | 0 | 6 | 0 | 3 | 0 | 9 | 181 | 4 | 0 | 2 | 1 | 0 | 0 | 386 |
| 13:45 | 5 | 147 | 0 | 0 | 6 | 2 | 3 | 0 | 5 | 182 | 4 | 0 | 2 | 2 | 0 | 0 | 358 |
| Total | 25 | 702 | 10 | 0 | 25 | 5 | 18 | 0 | 28 | 695 | 11 | 0 | 10 | 4 | 3 | 0 | 1536 |
| 14:00 | 13 | 150 | 2 | 0 | 6 | 1 | 2 | 0 | 2 | 187 | 3 | 0 | 5 | 2 | 3 | 0 | 376 |
| 14:15 | 9 | 161 | 3 | 0 | 6 | 0 | 4 | 0 | 11 | 166 | 3 | 0 | 3 | 1 | 0 | 0 | 367 |
| 14:30 | 7 | 154 | 3 | 0 | 5 | 1 | 7 | 0 | 8 | 207 | 5 | 0 | 2 | 1 | 1 | 0 | 401 |
| 14:45 | 6 | 177 | 3 | 0 | 3 | 1 | 6 | 0 | 10 | 187 | 8 | 0 | 3 | 3 | 3 | 0 | 410 |
| Total | 35 | 642 | 11 | 0 | 20 | 3 | 19 | 0 | 31 | 747 | 19 | 0 | 13 | 7 | 7 | 0 | 1554 |
| 15:00 | 7 | 159 | 1 | 0 | 5 | 1 | 8 | 0 | 9 | 170 | 4 | 0 | 1 | 2 | 0 | 0 | 367 |
| 15:15 | 4 | 185 | 6 | 3 | 7 | 1 | 2 | 0 | 12 | 182 | 2 | 2 | 3 | 0 | 0 | 2 | 411 |
| 15:30 | 4 | 193 | 2 | 3 | 5 | 1 | 4 | 1 | 9 | 193 | 4 | 2 | 2 | 1 | 2 | 2 | 428 |
| 15:45 | 7 | 178 | 0 | 1 | 4 | 1 | 2 | 2 | 9 | 210 | 2 | 3 | 3 | 4 | 2 | 5 | 433 |
| Total | 22 | 715 | 9 | 7 | 21 | 4 | 16 | 3 | 39 | 755 | 12 | 7 | 9 | 7 | 4 | 9 | 1639 |

MN Dept of Transportation

TRAFFIC DATA COLLECTION - Metro

TH-41 at 2nd Street

CHASKA

File Name : th-41 at 2nd st CHASKA SAT 2015

Ref.Pt.: 001.740

Site Code :

video AL

Start Date : 6/27/2015

TURN MOVEMENT COUNT - Saturday

Page No : 2

Groups Printed- Cars +

| Start Time | TH-41 SB Southbound | | | | 2nd St WB Westbound | | | | TH-41 NB Northbound | | | | 2nd St EB Eastbound | | | | Int. Total |
|-------------|---------------------|------|-------|------|---------------------|------|-------|------|---------------------|------|-------|------|---------------------|------|-------|------|------------|
| | Left | Thru | Right | Peds | Left | Thru | Right | Peds | Left | Thru | Right | Peds | Left | Thru | Right | Peds | |
| 16:00 | 4 | 173 | 1 | 0 | 2 | 2 | 2 | 0 | 8 | 172 | 2 | 0 | 4 | 1 | 2 | 0 | 373 |
| 16:15 | 2 | 177 | 6 | 0 | 8 | 1 | 4 | 0 | 6 | 202 | 2 | 1 | 2 | 0 | 2 | 3 | 416 |
| 16:30 | 2 | 179 | 7 | 0 | 4 | 4 | 2 | 1 | 10 | 174 | 1 | 1 | 1 | 1 | 0 | 2 | 389 |
| 16:45 | 7 | 186 | 23 | 1 | 7 | 3 | 6 | 3 | 15 | 196 | 1 | 3 | 2 | 0 | 1 | 2 | 456 |
| Total | 15 | 715 | 37 | 1 | 21 | 10 | 14 | 4 | 39 | 744 | 6 | 5 | 9 | 2 | 5 | 7 | 1634 |
| 17:00 | 6 | 172 | 14 | 1 | 4 | 4 | 3 | 0 | 13 | 176 | 4 | 0 | 1 | 1 | 3 | 2 | 404 |
| 17:15 | 7 | 171 | 9 | 0 | 5 | 1 | 3 | 1 | 7 | 182 | 0 | 2 | 2 | 2 | 3 | 13 | 408 |
| 17:30 | 3 | 162 | 8 | 0 | 2 | 1 | 3 | 4 | 11 | 175 | 3 | 6 | 4 | 0 | 0 | 3 | 385 |
| 17:45 | 8 | 144 | 4 | 1 | 3 | 1 | 1 | 0 | 7 | 161 | 1 | 0 | 1 | 1 | 0 | 0 | 333 |
| Total | 24 | 649 | 35 | 2 | 14 | 7 | 10 | 5 | 38 | 694 | 8 | 8 | 8 | 4 | 6 | 18 | 1530 |
| Grand Total | 352 | 7187 | 153 | 31 | 229 | 58 | 191 | 116 | 301 | 7344 | 118 | 49 | 156 | 66 | 69 | 57 | 16477 |
| Apprch % | 4.6 | 93.1 | 2 | 0.4 | 38.6 | 9.8 | 32.2 | 19.5 | 3.9 | 94 | 1.5 | 0.6 | 44.8 | 19 | 19.8 | 16.4 | |
| Total % | 2.1 | 43.6 | 0.9 | 0.2 | 1.4 | 0.4 | 1.2 | 0.7 | 1.8 | 44.6 | 0.7 | 0.3 | 0.9 | 0.4 | 0.4 | 0.3 | |

MN Dept of Transportation

TRAFFIC DATA COLLECTION - Metro

TH-41 at 2nd Street CHASKA
 Ref.Pt.: 001.740
 video AL
 TURN MOVEMENT COUNT - Saturday

File Name : th-41 at 2nd st CHASKA SAT 2015
 Site Code :
 Start Date : 6/27/2015
 Page No : 3

| Start Time | TH-41 SB Southbound | | | | | 2nd St WB Westbound | | | | | TH-41 NB Northbound | | | | | 2nd St EB Eastbound | | | | | Int. Total |
|------------------------------------------------------|---------------------|------|-------|------|------------|---------------------|------|-------|------|------------|---------------------|------|-------|------|------------|---------------------|------|-------|------|------------|------------|
| | Left | Thru | Right | Peds | App. Total | Left | Thru | Right | Peds | App. Total | Left | Thru | Right | Peds | App. Total | Left | Thru | Right | Peds | App. Total | |
| Peak Hour Analysis From 06:00 to 08:45 - Peak 1 of 1 | | | | | | | | | | | | | | | | | | | | | |
| Peak Hour for Entire Intersection Begins at 08:00 | | | | | | | | | | | | | | | | | | | | | |
| 08:00 | 6 | 91 | 0 | 0 | 97 | 2 | 1 | 1 | 1 | 5 | 4 | 81 | 4 | 0 | 89 | 1 | 1 | 0 | 0 | 2 | 193 |
| 08:15 | 5 | 109 | 1 | 0 | 115 | 5 | 0 | 4 | 2 | 11 | 5 | 110 | 0 | 1 | 116 | 1 | 0 | 1 | 1 | 3 | 245 |
| 08:30 | 9 | 114 | 0 | 3 | 126 | 4 | 1 | 3 | 4 | 12 | 4 | 136 | 0 | 0 | 140 | 5 | 0 | 3 | 1 | 9 | 287 |
| 08:45 | 9 | 117 | 2 | 0 | 128 | 7 | 1 | 3 | 8 | 19 | 5 | 142 | 3 | 2 | 152 | 4 | 2 | 0 | 0 | 6 | 305 |
| Total Volume | 29 | 431 | 3 | 3 | 466 | 18 | 3 | 11 | 15 | 47 | 18 | 469 | 7 | 3 | 497 | 11 | 3 | 4 | 2 | 20 | 1030 |
| % App. Total | 6.2 | 92.5 | 0.6 | 0.6 | | 38.3 | 6.4 | 23.4 | 31.9 | | 3.6 | 94.4 | 1.4 | 0.6 | | 55 | 15 | 20 | 10 | | |
| PHF | .806 | .921 | .375 | .250 | .910 | .643 | .750 | .688 | .469 | .618 | .900 | .826 | .438 | .375 | .817 | .550 | .375 | .333 | .500 | .556 | .844 |

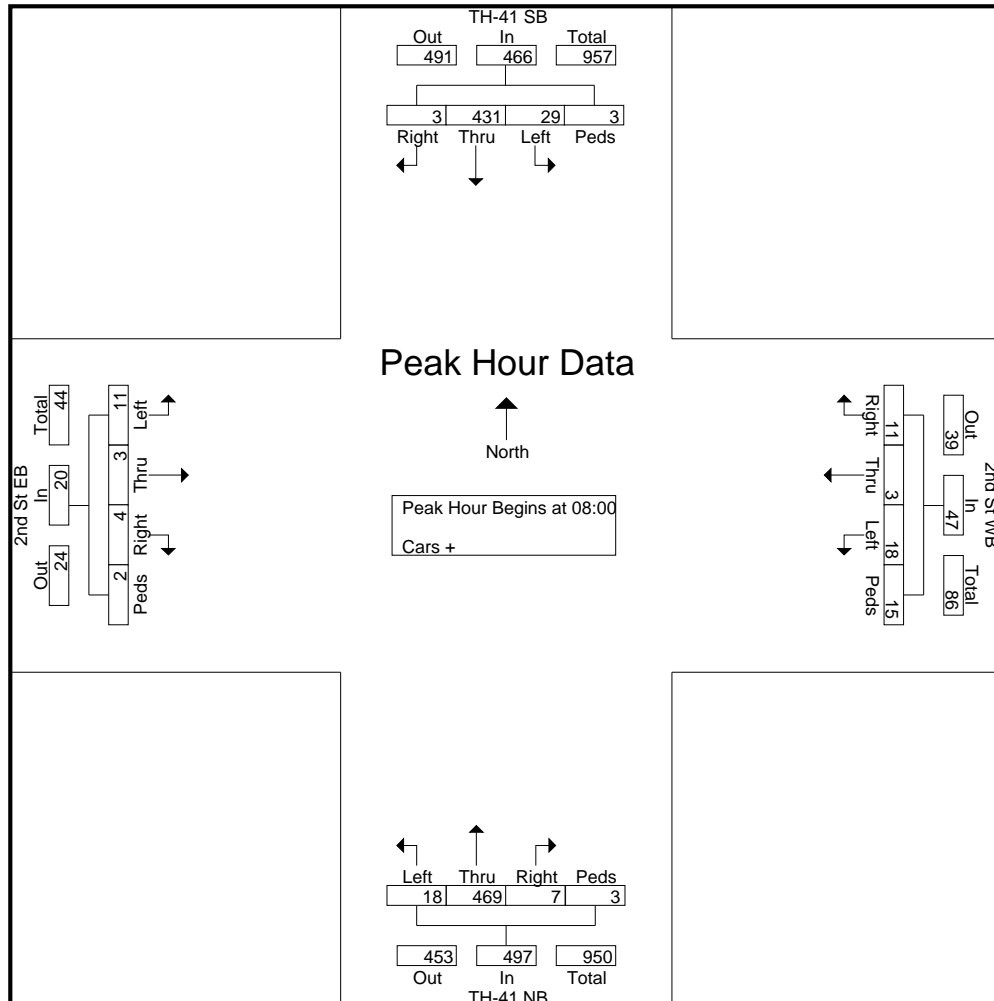

MN Dept of Transportation

TRAFFIC DATA COLLECTION - Metro

TH-41 at 2nd Street
 Ref.Pt.: 001.740
 video AL
 TURN MOVEMENT COUNT - Saturday

CHASKA

File Name : th-41 at 2nd st CHASKA SAT 2015
 Site Code :
 Start Date : 6/27/2015
 Page No : 4

| Start Time | TH-41 SB Southbound | | | | | 2nd St WB Westbound | | | | | TH-41 NB Northbound | | | | | 2nd St EB Eastbound | | | | | Int. Total |
|------------------------------------------------------|---------------------|------|-------|------|------------|---------------------|------|-------|------|------------|---------------------|------|-------|------|------------|---------------------|------|-------|------|------------|------------|
| | Left | Thru | Right | Peds | App. Total | Left | Thru | Right | Peds | App. Total | Left | Thru | Right | Peds | App. Total | Left | Thru | Right | Peds | App. Total | |
| Peak Hour Analysis From 15:00 to 17:45 - Peak 1 of 1 | | | | | | | | | | | | | | | | | | | | | |
| Peak Hour for Entire Intersection Begins at 16:15 | | | | | | | | | | | | | | | | | | | | | |
| 16:15 | 2 | 177 | 6 | 0 | 185 | 8 | 1 | 4 | 0 | 13 | 6 | 202 | 2 | 1 | 211 | 2 | 0 | 2 | 3 | 7 | 416 |
| 16:30 | 2 | 179 | 7 | 0 | 188 | 4 | 4 | 2 | 1 | 11 | 10 | 174 | 1 | 1 | 186 | 1 | 1 | 0 | 2 | 4 | 389 |
| 16:45 | 7 | 186 | 23 | 1 | 217 | 7 | 3 | 6 | 3 | 19 | 15 | 196 | 1 | 3 | 215 | 2 | 0 | 1 | 2 | 5 | 456 |
| 17:00 | 6 | 172 | 14 | 1 | 193 | 4 | 4 | 3 | 0 | 11 | 13 | 176 | 4 | 0 | 193 | 1 | 1 | 3 | 2 | 7 | 404 |
| Total Volume | 17 | 714 | 50 | 2 | 783 | 23 | 12 | 15 | 4 | 54 | 44 | 748 | 8 | 5 | 805 | 6 | 2 | 6 | 9 | 23 | 1665 |
| % App. Total | 2.2 | 91.2 | 6.4 | 0.3 | | 42.6 | 22.2 | 27.8 | 7.4 | | 5.5 | 92.9 | 1 | 0.6 | | 26.1 | 8.7 | 26.1 | 39.1 | | |
| PHF | .607 | .960 | .543 | .500 | .902 | .719 | .750 | .625 | .333 | .711 | .733 | .926 | .500 | .417 | .936 | .750 | .500 | .500 | .750 | .821 | .913 |

