



# MINNESOTA DEPT OF TRANSPORTATION

## TRAFFIC DATA COLLECTION - METRO

TH-36 at TH-120 / Century Ave

Ref.Pt.: 010.463

JAMAR # 632 JI / MR

TURN MOVEMENT COUNT - 12 hour

File Name : TH-36 at TH-120 2013

Site Code : 00036121

Start Date : 1/9/2013

Page No : 1

### Groups Printed- Cars & Trucks

Start Time	TH-120 Century Ave Southbound				TH-36 Westbound				TH-120 Century Ave Northbound				TH-36 Eastbound				Int. Total
	Left	Thru	Right	Peds	Left	Thru	Right	Peds	Left	Thru	Right	Peds	Left	Thru	Right	Peds	
06:00	5	14	18	0	5	170	2	0	46	21	7	0	4	39	9	0	340
06:15	11	13	25	0	3	272	5	0	59	20	5	0	13	60	8	0	494
06:30	8	15	25	0	6	346	3	0	47	19	7	0	6	75	11	0	568
06:45	19	25	20	0	9	331	9	0	59	38	3	0	19	118	23	0	673
Total	43	67	88	0	23	1119	19	0	211	98	22	0	42	292	51	0	2075
07:00	10	43	31	0	24	329	2	0	62	37	2	0	14	85	20	0	659
07:15	17	33	27	0	15	375	9	0	54	35	5	0	14	146	30	0	760
07:30	17	35	31	0	11	356	8	0	52	59	4	0	10	170	31	0	784
07:45	23	28	29	0	14	341	11	0	57	66	10	0	31	185	35	0	830
Total	67	139	118	0	64	1401	30	0	225	197	21	0	69	586	116	0	3033
08:00	23	31	32	0	10	393	14	0	36	45	4	0	22	137	31	0	778
08:15	11	36	27	0	19	299	7	0	47	27	10	0	31	175	31	0	720
08:30	18	45	35	1	10	266	6	0	46	42	5	0	15	176	27	0	692
08:45	16	21	35	0	8	246	11	0	57	50	6	0	14	165	22	0	651
Total	68	133	129	1	47	1204	38	0	186	164	25	0	82	653	111	0	2841
09:00	12	38	21	0	18	246	19	0	40	38	4	0	17	120	26	0	599
09:15	17	44	25	0	17	200	8	0	48	31	8	0	15	120	32	0	565
09:30	12	36	27	0	10	193	2	0	41	31	9	0	22	134	29	0	546
09:45	9	44	19	0	9	204	6	0	42	40	12	0	14	136	30	0	565
Total	50	162	92	0	54	843	35	0	171	140	33	0	68	510	117	0	2275
10:00	7	35	16	0	12	167	4	0	35	29	10	0	12	112	36	0	475
10:15	6	39	19	0	10	177	5	0	31	38	16	0	18	123	29	0	511
10:30	17	23	15	0	10	181	7	0	30	25	17	0	24	133	37	0	519
10:45	9	33	21	0	13	193	8	0	33	46	18	0	24	147	32	0	577
Total	39	130	71	0	45	718	24	0	129	138	61	0	78	515	134	0	2082
11:00	14	32	18	1	11	148	6	0	34	41	11	0	28	134	39	0	517
11:15	10	31	25	0	22	193	8	0	53	42	12	0	21	130	34	0	581
11:30	10	38	14	0	27	194	12	0	36	39	14	0	29	176	39	0	628
11:45	19	33	22	0	16	184	6	0	31	42	26	0	31	163	49	0	622
Total	53	134	79	1	76	719	32	0	154	164	63	0	109	603	161	0	2348
12:00	11	37	36	0	18	158	8	0	35	53	27	0	37	162	39	0	621
12:15	13	42	26	0	24	163	8	0	42	50	20	0	30	180	35	0	633
12:30	13	42	25	0	18	149	12	0	49	54	15	0	41	165	46	0	629
12:45	20	30	29	0	21	171	15	0	39	45	17	0	37	169	44	0	637
Total	57	151	116	0	81	641	43	0	165	202	79	0	145	676	164	0	2520
13:00	12	41	38	0	22	183	6	0	38	45	17	0	26	190	39	1	658
13:15	15	34	27	0	13	144	3	0	38	51	18	0	35	191	46	1	616
13:30	19	40	20	0	14	162	7	0	42	56	22	0	38	183	38	0	641
13:45	6	52	20	1	18	169	5	0	47	60	30	0	32	174	59	0	673
Total	52	167	105	1	67	658	21	0	165	212	87	0	131	738	182	2	2588
14:00	15	39	18	0	19	155	7	0	39	37	16	0	28	208	47	0	628
14:15	16	50	19	0	22	157	7	0	42	43	19	0	35	215	41	0	666
14:30	23	55	31	0	8	156	6	1	44	46	11	0	39	213	45	0	678
14:45	23	45	19	0	23	199	12	0	43	51	20	0	44	231	62	1	773
Total	77	189	87	0	72	667	32	1	168	177	66	0	146	867	195	1	2745



# MINNESOTA DEPT OF TRANSPORTATION

## TRAFFIC DATA COLLECTION - METRO

TH-36 at TH-120 / Century Ave  
 Ref.Pt.: 010.463  
 JAMAR # 632 JI / MR  
 TURN MOVEMENT COUNT - 12 hour

File Name : TH-36 at TH-120 2013  
 Site Code : 00036121  
 Start Date : 1/9/2013  
 Page No : 2

### Groups Printed- Cars & Trucks

Start Time	TH-120 Century Ave Southbound				TH-36 Westbound				TH-120 Century Ave Northbound				TH-36 Eastbound				Int. Total
	Left	Thru	Right	Peds	Left	Thru	Right	Peds	Left	Thru	Right	Peds	Left	Thru	Right	Peds	
15:00	30	40	33	0	24	158	15	0	46	42	17	0	45	220	60	0	730
15:15	27	54	36	0	18	178	8	0	37	50	22	0	23	282	66	1	802
15:30	18	44	18	0	28	187	12	0	30	44	21	0	46	298	62	1	809
15:45	19	47	22	0	16	260	22	0	49	47	22	0	40	295	74	0	913
Total	94	185	109	0	86	783	57	0	162	183	82	0	154	1095	262	2	3254
16:00	26	64	39	0	23	218	3	0	35	53	18	0	53	324	54	0	910
16:15	28	81	50	0	15	197	9	0	38	55	28	0	49	339	71	0	960
16:30	18	60	41	0	20	197	21	0	36	65	15	0	39	315	55	0	882
16:45	23	45	24	0	14	260	15	0	53	52	13	0	39	359	67	1	965
Total	95	250	154	0	72	872	48	0	162	225	74	0	180	1337	247	1	3717
17:00	20	58	18	0	14	250	16	0	38	44	10	0	39	414	56	1	978
17:15	21	62	35	0	14	202	13	1	50	48	17	0	37	374	56	0	930
17:30	19	55	34	0	14	188	10	0	40	41	11	0	38	304	59	0	813
17:45	16	49	35	0	19	222	19	0	43	52	8	0	38	321	62	0	884
Total	76	224	122	0	61	862	58	1	171	185	46	0	152	1413	233	1	3605
Grand Total	771	1931	1270	3	748	10487	437	2	2069	2085	659	0	1356	9285	1973	7	33083
Apprch %	19.4	48.6	31.9	0.1	6.4	89.8	3.7	0	43	43.3	13.7	0	10.7	73.6	15.6	0.1	
Total %	2.3	5.8	3.8	0	2.3	31.7	1.3	0	6.3	6.3	2	0	4.1	28.1	6	0	



# MINNESOTA DEPT OF TRANSPORTATION

## TRAFFIC DATA COLLECTION - METRO

TH-36 at TH-120 / Century Ave  
 Ref.Pt.: 010.463  
 JAMAR # 632 JI / MR  
 TURN MOVEMENT COUNT - 12 hour

File Name : TH-36 at TH-120 2013  
 Site Code : 00036121  
 Start Date : 1/9/2013  
 Page No : 3

Start Time	TH-120 Century Ave Southbound					TH-36 Westbound					TH-120 Century Ave Northbound					TH-36 Eastbound					Int. Total
	Left	Thru	Right	Peds	App. Total	Left	Thru	Right	Peds	App. Total	Left	Thru	Right	Peds	App. Total	Left	Thru	Right	Peds	App. Total	
Peak Hour Analysis From 06:00 to 09:00 - Peak 1 of 1																					
Peak Hour for Entire Intersection Begins at 07:15																					
07:15	17	33	27	0	77	15	375	9	0	399	54	35	5	0	94	14	146	30	0	190	760
07:30	17	35	31	0	83	11	356	8	0	375	52	59	4	0	115	10	170	31	0	211	784
07:45	23	28	29	0	80	14	341	11	0	366	57	66	10	0	133	31	185	35	0	251	830
08:00	23	31	32	0	86	10	393	14	0	417	36	45	4	0	85	22	137	31	0	190	778
Total Volume	80	127	119	0	326	50	1465	42	0	1557	199	205	23	0	427	77	638	127	0	842	3152
% App. Total	24.5	39	36.5	0		3.2	94.1	2.7	0		46.6	48	5.4	0		9.1	75.8	15.1	0		
PHF	.870	.907	.930	.000	.948	.833	.932	.750	.000	.933	.873	.777	.575	.000	.803	.621	.862	.907	.000	.839	.949

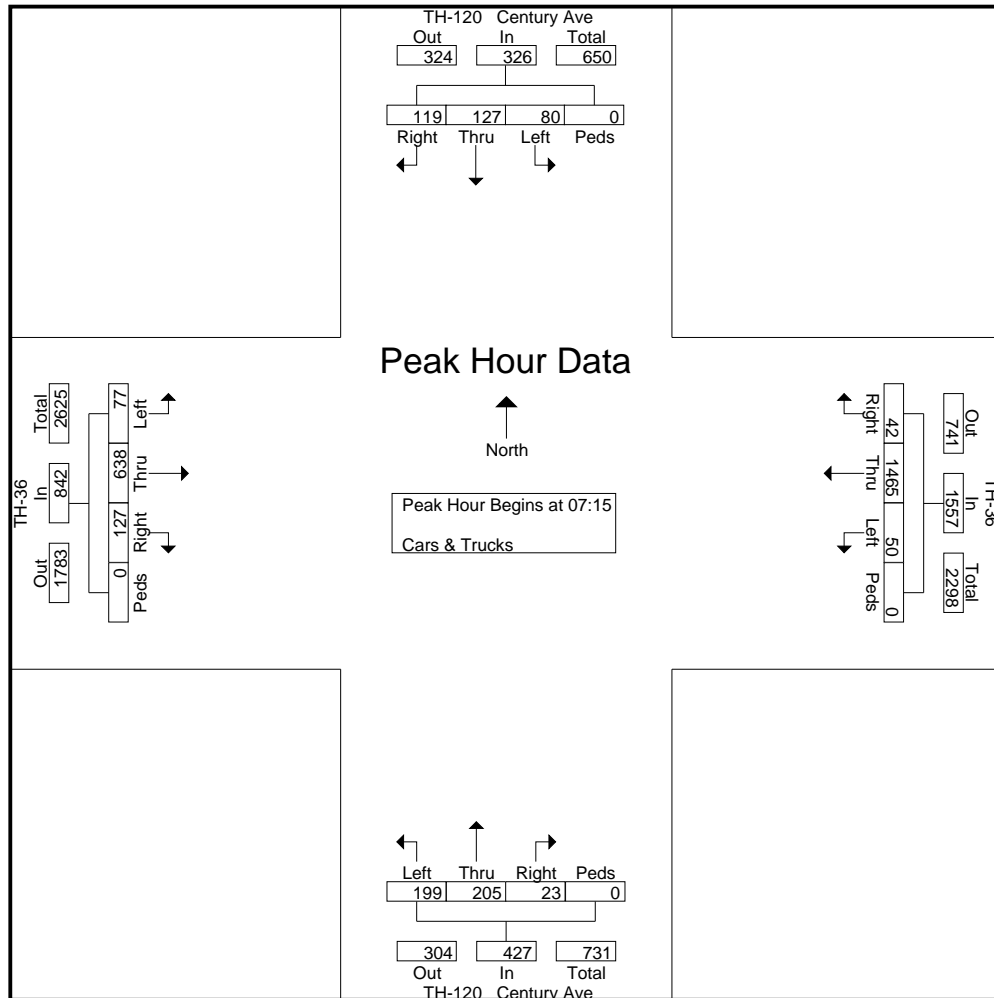



# MINNESOTA DEPT OF TRANSPORTATION

## TRAFFIC DATA COLLECTION - METRO

TH-36 at TH-120 / Century Ave  
 Ref.Pt.: 010.463  
 JAMAR # 632 JI / MR  
 TURN MOVEMENT COUNT - 12 hour

File Name : TH-36 at TH-120 2013  
 Site Code : 00036121  
 Start Date : 1/9/2013  
 Page No : 4

Start Time	TH-120 Century Ave Southbound					TH-36 Westbound					TH-120 Century Ave Northbound					TH-36 Eastbound					Int. Total
	Left	Thru	Right	Peds	App. Total	Left	Thru	Right	Peds	App. Total	Left	Thru	Right	Peds	App. Total	Left	Thru	Right	Peds	App. Total	
16:15	28	81	50	0	159	15	197	9	0	221	38	55	28	0	121	49	339	71	0	459	960
16:30	18	60	41	0	119	20	197	21	0	238	36	65	15	0	116	39	315	55	0	409	882
16:45	23	45	24	0	92	14	260	15	0	289	53	52	13	0	118	39	359	67	1	466	965
17:00	20	58	18	0	96	14	250	16	0	280	38	44	10	0	92	39	414	56	1	510	978
Total Volume	89	244	133	0	466	63	904	61	0	1028	165	216	66	0	447	166	1427	249	2	1844	3785
% App. Total	19.1	52.4	28.5	0		6.1	87.9	5.9	0		36.9	48.3	14.8	0		9	77.4	13.5	0.1		
PHF	.795	.753	.665	.000	.733	.788	.869	.726	.000	.889	.778	.831	.589	.000	.924	.847	.862	.877	.500	.904	.968

Peak Hour Analysis From 15:00 to 17:45 - Peak 1 of 1  
 Peak Hour for Entire Intersection Begins at 16:15

