



MINNESOTA DEPT OF TRANSPORTATION

TRAFFIC DATA COLLECTION - METRO

TH-316 at Tuttle Drive HASTINGS
 Ref.Pt.: 008.793
 JAMAR #D4-3365 CH
 TURN MOVEMENT COUNT

File Name : TH-316 at Tuttle Dr 2009
 Site Code : 00000000
 Start Date : 6/17/2009
 Page No : 1

Groups Printed- Cars & Trucks

Start Time	TH 316 Southbound				TUTTLE DRIVE Westbound				TH 316 Northbound				TUTTLE DRIVE Eastbound				Int. Total
	Left	Thru	Right	Peds	Left	Thru	Right	Peds	Left	Thru	Right	Peds	Left	Thru	Right	Peds	
06:00	0	32	2	0	1	0	10	0	0	53	0	0	6	0	0	0	104
06:15	6	49	0	0	1	0	27	0	0	67	0	0	3	0	0	0	153
06:30	4	37	2	1	0	0	18	0	0	57	1	0	7	0	1	0	128
06:45	2	29	0	0	0	0	36	0	0	65	2	0	6	0	0	0	140
Total	12	147	4	1	2	0	91	0	0	242	3	0	22	0	1	0	525
07:00	8	44	4	0	2	0	33	2	0	58	1	2	13	0	1	0	168
07:15	10	30	2	1	0	0	21	0	0	57	1	0	10	0	0	3	135
07:30	10	40	3	0	4	0	21	0	0	48	1	0	4	0	0	0	131
07:45	11	31	2	0	1	2	24	0	0	62	0	0	12	0	0	0	145
Total	39	145	11	1	7	2	99	2	0	225	3	2	39	0	1	3	579
08:00	10	32	2	0	0	0	20	1	0	42	1	0	6	1	0	0	115
08:15	9	27	1	0	0	0	21	0	0	47	0	0	5	0	0	0	110
08:30	8	30	1	1	0	1	19	0	1	37	0	0	8	0	0	0	106
08:45	8	31	5	0	0	1	16	0	0	22	1	0	7	0	0	0	91
Total	35	120	9	1	0	2	76	1	1	148	2	0	26	1	0	0	422
15:00	9	73	3	0	1	0	17	2	0	48	1	0	4	0	0	0	158
15:15	15	55	7	0	0	0	14	0	0	67	4	0	4	1	0	0	167
15:30	15	62	10	0	2	0	12	0	0	51	1	1	6	0	0	1	161
15:45	17	63	3	0	2	0	16	0	1	54	3	1	2	0	0	1	163
Total	56	253	23	0	5	0	59	2	1	220	9	2	16	1	0	2	649
16:00	18	73	7	0	1	0	11	2	1	50	1	0	4	0	0	0	168
16:15	33	64	7	0	2	0	15	0	1	42	1	1	3	0	0	0	169
16:30	31	84	3	0	1	0	17	1	0	51	1	0	7	0	0	0	196
16:45	25	82	17	0	5	1	22	0	0	50	2	0	3	0	0	0	207
Total	107	303	34	0	9	1	65	3	2	193	5	1	17	0	0	0	740
17:00	39	70	10	1	2	0	16	0	0	58	2	0	7	1	0	0	206
17:15	35	81	11	0	1	1	19	0	0	71	2	4	8	0	1	0	234
17:30	23	71	11	0	3	0	28	0	3	50	3	1	6	0	2	0	201
17:45	34	72	11	0	1	0	24	0	1	77	2	1	9	0	0	0	232
Total	131	294	43	1	7	1	87	0	4	256	9	6	30	1	3	0	873
Grand Total	380	1262	124	4	30	6	477	8	8	1284	31	11	150	3	5	5	3788
Apprch %	21.5	71.3	7	0.2	5.8	1.2	91.6	1.5	0.6	96.3	2.3	0.8	92	1.8	3.1	3.1	
Total %	10	33.3	3.3	0.1	0.8	0.2	12.6	0.2	0.2	33.9	0.8	0.3	4	0.1	0.1	0.1	



MINNESOTA DEPT OF TRANSPORTATION

TRAFFIC DATA COLLECTION - METRO

TH-316 at Tuttle Drive HASTINGS
 Ref.Pt.: 008.793
 JAMAR #D4-3365 CH
 TURN MOVEMENT COUNT

File Name : TH-316 at Tuttle Dr 2009
 Site Code : 00000000
 Start Date : 6/17/2009
 Page No : 2

Start Time	TH 316 Southbound					TUTTLE DRIVE Westbound					TH 316 Northbound					TUTTLE DRIVE Eastbound					Int. Total
	Left	Thru	Right	Peds	App. Total	Left	Thru	Right	Peds	App. Total	Left	Thru	Right	Peds	App. Total	Left	Thru	Right	Peds	App. Total	
Peak Hour Analysis From 06:00 to 08:45 - Peak 1 of 1																					
Peak Hour for Entire Intersection Begins at 06:15																					
06:15	6	49	0	0	55	1	0	27	0	28	0	67	0	0	67	3	0	0	0	3	153
06:30	4	37	2	1	44	0	0	18	0	18	0	57	1	0	58	7	0	1	0	8	128
06:45	2	29	0	0	31	0	0	36	0	36	0	65	2	0	67	6	0	0	0	6	140
07:00	8	44	4	0	56	2	0	33	2	37	0	58	1	2	61	13	0	1	0	14	168
Total Volume	20	159	6	1	186	3	0	114	2	119	0	247	4	2	253	29	0	2	0	31	589
% App. Total	10.8	85.5	3.2	0.5		2.5	0	95.8	1.7		0	97.6	1.6	0.8		93.5	0	6.5	0		
PHF	.625	.811	.375	.250	.830	.375	.000	.792	.250	.804	.000	.922	.500	.250	.944	.558	.000	.500	.000	.554	.876

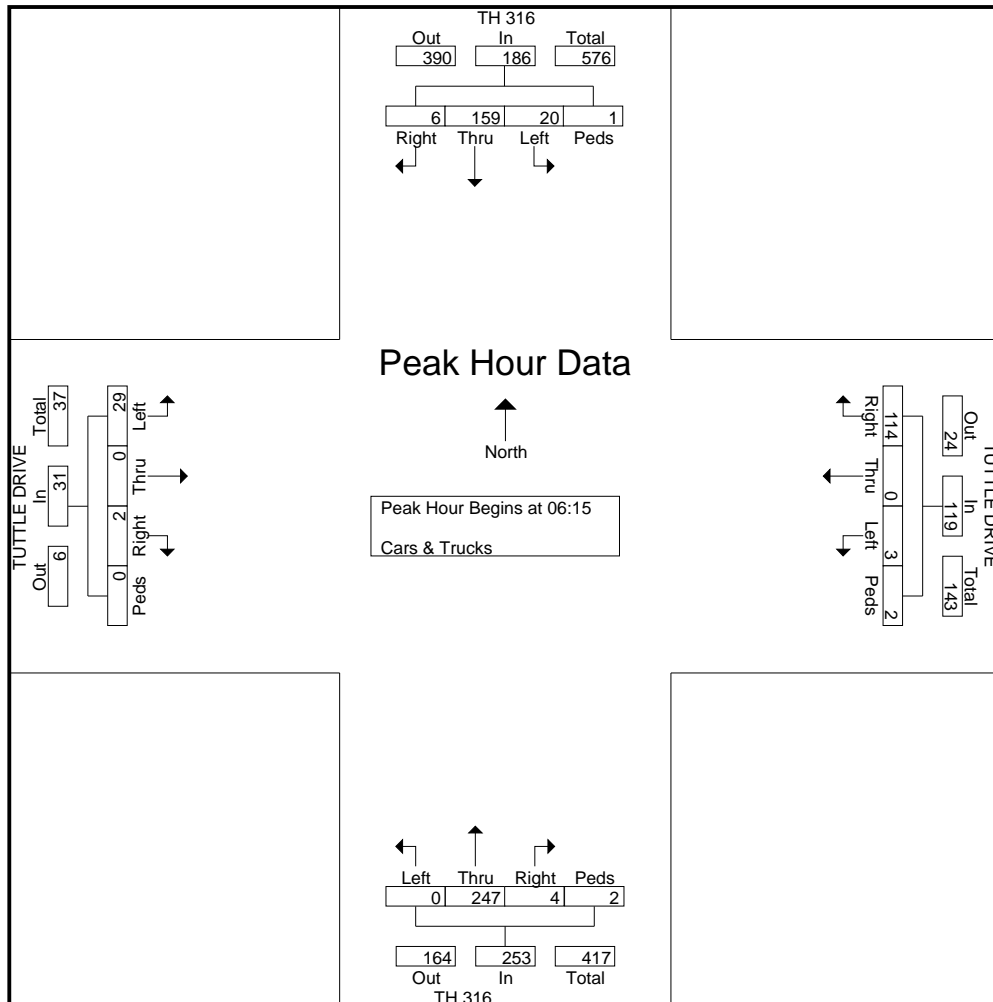



MINNESOTA DEPT OF TRANSPORTATION

TRAFFIC DATA COLLECTION - METRO

TH-316 at Tuttle Drive HASTINGS
 Ref.Pt.: 008.793
 JAMAR #D4-3365 CH
 TURN MOVEMENT COUNT

File Name : TH-316 at Tuttle Dr 2009
 Site Code : 00000000
 Start Date : 6/17/2009
 Page No : 3

Start Time	TH 316 Southbound					TUTTLE DRIVE Westbound					TH 316 Northbound					TUTTLE DRIVE Eastbound					Int. Total
	Left	Thru	Right	Peds	App. Total	Left	Thru	Right	Peds	App. Total	Left	Thru	Right	Peds	App. Total	Left	Thru	Right	Peds	App. Total	
Peak Hour Analysis From 15:00 to 17:45 - Peak 1 of 1																					
Peak Hour for Entire Intersection Begins at 17:00																					
17:00	39	70	10	1	120	2	0	16	0	18	0	58	2	0	60	7	1	0	0	8	206
17:15	35	81	11	0	127	1	1	19	0	21	0	71	2	4	77	8	0	1	0	9	234
17:30	23	71	11	0	105	3	0	28	0	31	3	50	3	1	57	6	0	2	0	8	201
17:45	34	72	11	0	117	1	0	24	0	25	1	77	2	1	81	9	0	0	0	9	232
Total Volume	131	294	43	1	469	7	1	87	0	95	4	256	9	6	275	30	1	3	0	34	873
% App. Total	27.9	62.7	9.2	0.2		7.4	1.1	91.6	0		1.5	93.1	3.3	2.2		88.2	2.9	8.8	0		
PHF	.840	.907	.977	.250	.923	.583	.250	.777	.000	.766	.333	.831	.750	.375	.849	.833	.250	.375	.000	.944	.933

