



MINNESOTA DEPT OF TRANSPORTATION

TRAFFIC DATA COLLECTION - METRO

TH-3 at 70th St / CSAH-26
 Ref.Pt.: 041.713
 JAMAR # D4-3365 CH
 TURN MOVEMENT COUNT

File Name : TH-3 at 70th St CSAH-26 2009
 Site Code : 00000000
 Start Date : 7/14/2009
 Page No : 1

Groups Printed- Cars & Trucks

Start Time	TH-3 Southbound				70th ST. / CSAH-26 Westbound				TH-3 Northbound				70th ST. / CSAH-26 Eastbound				Int. Total
	Left	Thru	Right	Peds	Left	Thru	Right	Peds	Left	Thru	Right	Peds	Left	Thru	Right	Peds	
06:00	1	15	8	0	20	38	2	0	1	21	18	0	1	9	1	0	135
06:15	1	11	9	0	17	38	4	1	7	32	23	0	0	4	3	0	150
06:30	4	19	19	0	12	49	4	0	8	39	38	0	8	15	3	0	218
06:45	4	15	24	0	13	63	4	3	12	54	34	0	7	12	4	0	249
Total	10	60	60	0	62	188	14	4	28	146	113	0	16	40	11	0	752
07:00	2	13	13	0	11	63	8	1	13	55	46	0	5	18	1	0	249
07:15	3	15	26	0	9	83	7	0	9	79	38	0	5	18	4	0	296
07:30	2	21	32	0	6	95	6	0	14	89	56	1	9	19	0	0	350
07:45	2	27	33	0	13	85	4	0	12	90	49	0	8	19	3	0	345
Total	9	76	104	0	39	326	25	1	48	313	189	1	27	74	8	0	1240
08:00	3	23	10	0	8	60	7	0	3	56	51	0	8	21	3	0	253
08:15	8	21	14	0	12	55	5	0	2	61	36	1	11	11	2	0	239
08:30	2	37	10	0	11	43	6	0	3	48	31	0	7	18	2	0	218
08:45	3	21	10	0	12	46	7	1	5	42	23	0	5	30	1	0	206
Total	16	102	44	0	43	204	25	1	13	207	141	1	31	80	8	0	916
*** BREAK ***																	
15:00	9	39	17	0	13	30	6	0	2	36	38	0	18	50	6	0	264
15:15	9	45	7	0	27	39	6	0	6	44	17	0	14	57	4	0	275
15:30	8	39	8	0	20	20	8	0	5	38	13	0	12	39	10	0	220
15:45	11	44	10	0	24	33	3	0	7	23	19	0	9	47	4	0	234
Total	37	167	42	0	84	122	23	0	20	141	87	0	53	193	24	0	993
16:00	11	65	12	0	28	19	4	0	2	36	22	0	17	89	7	0	312
16:15	5	68	12	0	23	32	10	0	5	32	20	0	17	73	12	1	310
16:30	13	80	15	0	39	36	3	0	5	33	24	0	20	87	12	1	368
16:45	9	80	10	0	49	29	3	0	4	48	15	0	18	91	8	0	364
Total	38	293	49	0	139	116	20	0	16	149	81	0	72	340	39	2	1354
17:00	10	71	20	0	54	36	3	0	3	48	25	0	17	81	8	3	379
17:15	12	94	14	0	51	51	6	0	3	35	30	0	22	82	8	0	408
17:30	20	71	11	0	48	36	5	0	2	36	29	0	14	65	14	0	351
17:45	11	63	5	0	34	36	5	0	1	34	9	0	15	46	6	0	265
Total	53	299	50	0	187	159	19	0	9	153	93	0	68	274	36	3	1403
Grand Total	163	997	349	0	554	1115	126	6	134	1109	704	2	267	1001	126	5	6658
Apprch %	10.8	66.1	23.1	0	30.8	61.9	7	0.3	6.9	56.9	36.1	0.1	19.1	71.6	9	0.4	
Total %	2.4	15	5.2	0	8.3	16.7	1.9	0.1	2	16.7	10.6	0	4	15	1.9	0.1	



MINNESOTA DEPT OF TRANSPORTATION

TRAFFIC DATA COLLECTION - METRO

TH-3 at 70th St / CSAH-26
 Ref.Pt.: 041.713
 JAMAR # D4-3365 CH
 TURN MOVEMENT COUNT

File Name : TH-3 at 70th St CSAH-26 2009
 Site Code : 00000000
 Start Date : 7/14/2009
 Page No : 2

Start Time	TH-3 Southbound					70th ST. / CSAH-26 Westbound					TH-3 Northbound					70th ST. / CSAH-26 Eastbound					Int. Total
	Left	Thru	Right	Peds	App. Total	Left	Thru	Right	Peds	App. Total	Left	Thru	Right	Peds	App. Total	Left	Thru	Right	Peds	App. Total	
Peak Hour Analysis From 06:00 to 08:45 - Peak 1 of 1																					
Peak Hour for Entire Intersection Begins at 07:15																					
07:15	3	15	26	0	44	9	83	7	0	99	9	79	38	0	126	5	18	4	0	27	296
07:30	2	21	32	0	55	6	95	6	0	107	14	89	56	1	160	9	19	0	0	28	350
07:45	2	27	33	0	62	13	85	4	0	102	12	90	49	0	151	8	19	3	0	30	345
08:00	3	23	10	0	36	8	60	7	0	75	3	56	51	0	110	8	21	3	0	32	253
Total Volume	10	86	101	0	197	36	323	24	0	383	38	314	194	1	547	30	77	10	0	117	1244
% App. Total	5.1	43.7	51.3	0		9.4	84.3	6.3	0		6.9	57.4	35.5	0.2		25.6	65.8	8.5	0		
PHF	.833	.796	.765	.000	.794	.692	.850	.857	.000	.895	.679	.872	.866	.250	.855	.833	.917	.625	.000	.914	.889

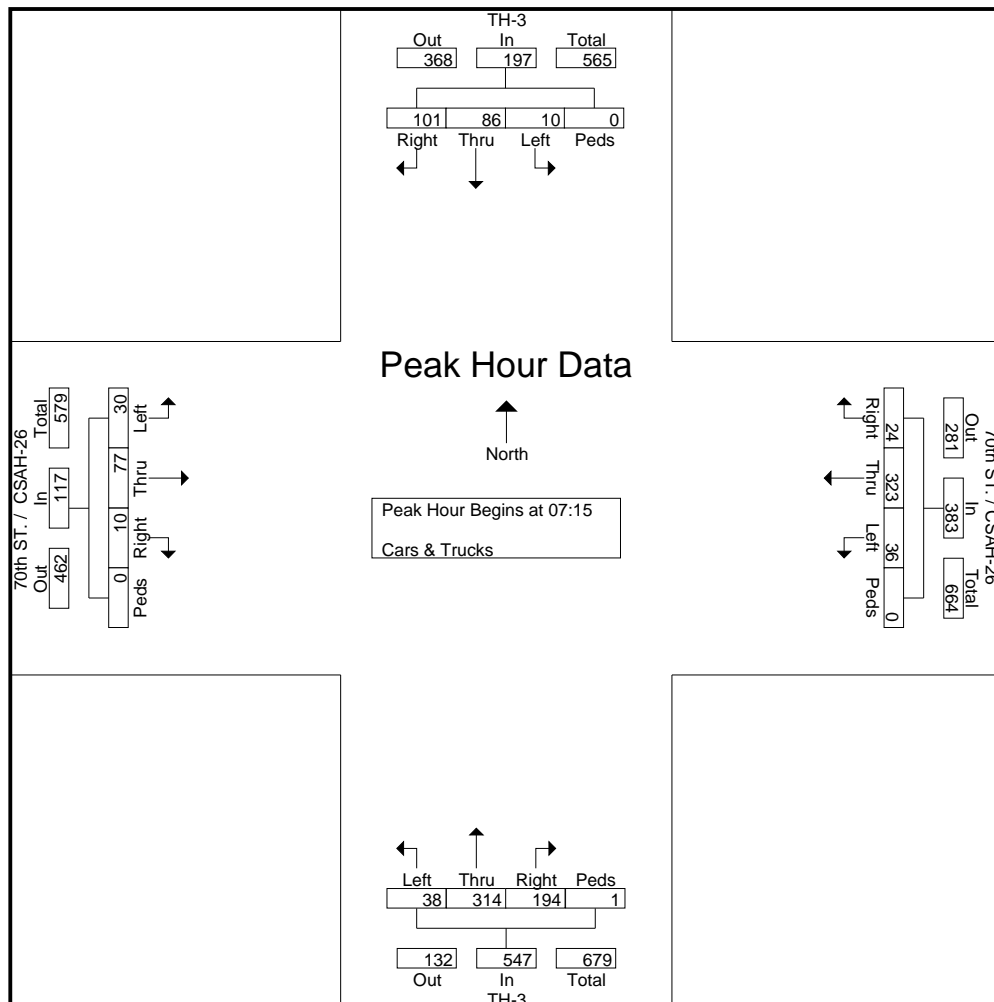



MINNESOTA DEPT OF TRANSPORTATION

TRAFFIC DATA COLLECTION - METRO

TH-3 at 70th St / CSAH-26
 Ref.Pt.: 041.713
 JAMAR # D4-3365 CH
 TURN MOVEMENT COUNT

File Name : TH-3 at 70th St CSAH-26 2009
 Site Code : 00000000
 Start Date : 7/14/2009
 Page No : 3

Start Time	TH-3 Southbound					70th ST. / CSAH-26 Westbound					TH-3 Northbound					70th ST. / CSAH-26 Eastbound					Int. Total
	Left	Thru	Right	Peds	App. Total	Left	Thru	Right	Peds	App. Total	Left	Thru	Right	Peds	App. Total	Left	Thru	Right	Peds	App. Total	
Peak Hour Analysis From 15:00 to 17:45 - Peak 1 of 1																					
Peak Hour for Entire Intersection Begins at 16:30																					
16:30	13	80	15	0	108	39	36	3	0	78	5	33	24	0	62	20	87	12	1	120	368
16:45	9	80	10	0	99	49	29	3	0	81	4	48	15	0	67	18	91	8	0	117	364
17:00	10	71	20	0	101	54	36	3	0	93	3	48	25	0	76	17	81	8	3	109	379
17:15	12	94	14	0	120	51	51	6	0	108	3	35	30	0	68	22	82	8	0	112	408
Total Volume	44	325	59	0	428	193	152	15	0	360	15	164	94	0	273	77	341	36	4	458	1519
% App. Total	10.3	75.9	13.8	0		53.6	42.2	4.2	0		5.5	60.1	34.4	0		16.8	74.5	7.9	0.9		
PHF	.846	.864	.738	.000	.892	.894	.745	.625	.000	.833	.750	.854	.783	.000	.898	.875	.937	.750	.333	.954	.931

