



MINNESOTA DEPT OF TRANSPORTATION

TRAFFIC DATA COLLECTION - METRO

TH-284 / Paul Ave at CSAH-36 / Lake St.
 Ref.Pt.: 000.444
 JAMAR # T2638 CAH
 TURN MOVEMENT COUNT

File Name : TH-284 at Lake St csah-36 2011
 Site Code : 00000000
 Start Date : 10/26/2011
 Page No : 1

Groups Printed- Cars & Trucks

Start Time	TH-284 / N Paul Ave Southbound				Lake St. / CSAH-36 Westbound				TH-284 / N Paul Ave Northbound				Lake St. / CSAH-36 Eastbound				Int. Total
	Left	Thru	Right	Peds	Left	Thru	Right	Peds	Left	Thru	Right	Peds	Left	Thru	Right	Peds	
06:00	10	16	3	0	0	0	1	0	0	7	1	0	1	0	1	0	40
06:15	13	16	4	0	0	0	1	0	2	9	2	1	0	0	1	0	49
06:30	21	26	3	1	0	0	5	0	1	13	3	0	3	0	2	0	78
06:45	8	18	4	0	1	3	1	1	2	13	4	0	4	1	2	0	62
Total	52	76	14	1	1	3	8	1	5	42	10	1	8	1	6	0	229
07:00	28	22	6	0	1	1	2	0	2	7	2	0	3	5	3	0	82
07:15	18	29	10	3	2	1	6	0	2	27	3	2	3	2	3	3	114
07:30	29	30	11	0	0	3	6	0	8	24	3	0	6	5	6	0	131
07:45	6	12	7	0	2	0	4	0	5	13	4	0	5	5	3	0	66
Total	81	93	34	3	5	5	18	0	17	71	12	2	17	17	15	3	393
08:00	5	13	2	0	1	0	2	0	0	9	0	0	1	3	3	0	39
08:15	6	25	9	0	1	1	1	0	3	17	4	0	5	0	0	0	72
08:30	7	25	6	0	2	2	1	0	2	16	2	0	5	1	2	0	71
08:45	5	16	5	0	0	0	0	0	4	20	2	0	4	1	1	0	58
Total	23	79	22	0	4	3	4	0	9	62	8	0	15	5	6	0	240
*** BREAK ***																	
15:00	4	29	4	0	1	2	8	0	5	22	1	0	4	0	3	0	83
15:15	2	21	9	0	2	3	5	0	6	12	0	0	8	0	3	0	71
15:30	4	23	10	0	2	4	8	0	3	18	2	0	11	6	5	0	96
15:45	6	30	6	0	1	3	12	1	4	34	1	0	16	4	5	0	123
Total	16	103	29	0	6	12	33	1	18	86	4	0	39	10	16	0	373
16:00	3	27	7	0	2	4	26	0	8	20	4	0	10	3	1	1	116
16:15	7	25	11	1	3	5	14	0	4	29	3	0	12	2	4	0	120
16:30	4	30	8	0	1	6	19	0	4	23	0	2	4	1	0	2	104
16:45	5	27	8	0	4	4	21	0	5	26	2	2	11	5	6	0	126
Total	19	109	34	1	10	19	80	0	21	98	9	4	37	11	11	3	466
17:00	6	21	8	1	2	0	16	0	3	33	7	0	3	2	3	0	105
17:15	8	24	9	0	2	5	22	0	3	32	1	0	10	2	2	0	120
17:30	4	20	9	0	2	1	14	0	6	20	0	0	20	1	1	0	98
17:45	8	17	9	2	3	3	4	0	8	24	2	0	7	1	1	0	89
Total	26	82	35	3	9	9	56	0	20	109	10	0	40	6	7	0	412
Grand Total	217	542	168	8	35	51	199	2	90	468	53	7	156	50	61	6	2113
Apprch %	23.2	58	18	0.9	12.2	17.8	69.3	0.7	14.6	75.7	8.6	1.1	57.1	18.3	22.3	2.2	
Total %	10.3	25.7	8	0.4	1.7	2.4	9.4	0.1	4.3	22.1	2.5	0.3	7.4	2.4	2.9	0.3	



MINNESOTA DEPT OF TRANSPORTATION

TRAFFIC DATA COLLECTION - METRO

TH-284 / Paul Ave at CSAH-36 / Lake St.
 Ref.Pt.: 000.444
 JAMAR # T2638 CAH
 TURN MOVEMENT COUNT

File Name : TH-284 at Lake St csah-36 2011
 Site Code : 00000000
 Start Date : 10/26/2011
 Page No : 2

Start Time	TH-284 / N Paul Ave Southbound					Lake St. / CSAH-36 Westbound					TH-284 / N Paul Ave Northbound					Lake St. / CSAH-36 Eastbound					Int. Total
	Left	Thru	Right	Peds	App. Total	Left	Thru	Right	Peds	App. Total	Left	Thru	Right	Peds	App. Total	Left	Thru	Right	Peds	App. Total	
Peak Hour Analysis From 06:00 to 08:45 - Peak 1 of 1																					
Peak Hour for Entire Intersection Begins at 07:00																					
07:00	28	22	6	0	56	1	1	2	0	4	2	7	2	0	11	3	5	3	0	11	82
07:15	18	29	10	3	60	2	1	6	0	9	2	27	3	2	34	3	2	3	3	11	114
07:30	29	30	11	0	70	0	3	6	0	9	8	24	3	0	35	6	5	6	0	17	131
07:45	6	12	7	0	25	2	0	4	0	6	5	13	4	0	22	5	5	3	0	13	66
Total Volume	81	93	34	3	211	5	5	18	0	28	17	71	12	2	102	17	17	15	3	52	393
% App. Total	38.4	44.1	16.1	1.4		17.9	17.9	64.3	0		16.7	69.6	11.8	2		32.7	32.7	28.8	5.8		
PHF	.698	.775	.773	.250	.754	.625	.417	.750	.000	.778	.531	.657	.750	.250	.729	.708	.850	.625	.250	.765	.750

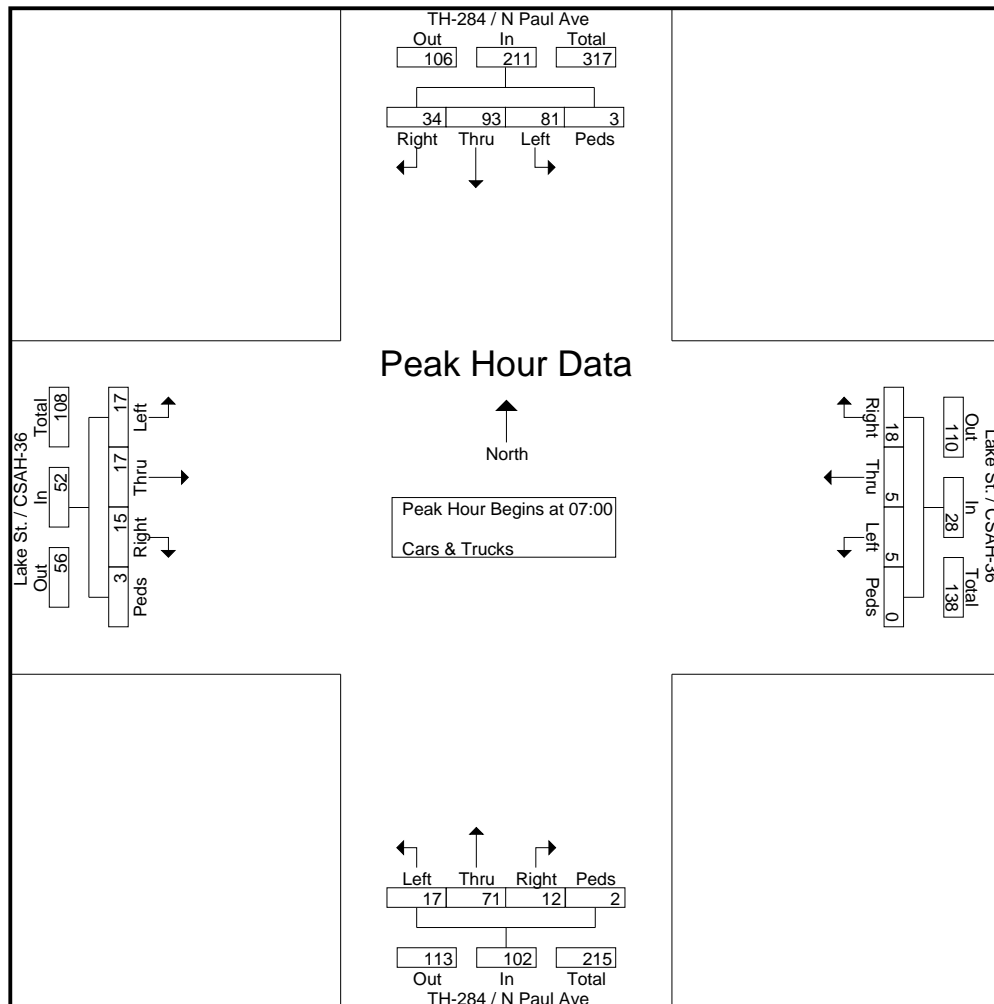



MINNESOTA DEPT OF TRANSPORTATION

TRAFFIC DATA COLLECTION - METRO

TH-284 / Paul Ave at CSAH-36 / Lake St.
 Ref.Pt.: 000.444
 JAMAR # T2638 CAH
 TURN MOVEMENT COUNT

File Name : TH-284 at Lake St csah-36 2011
 Site Code : 00000000
 Start Date : 10/26/2011
 Page No : 3

Start Time	TH-284 / N Paul Ave Southbound					Lake St. / CSAH-36 Westbound					TH-284 / N Paul Ave Northbound					Lake St. / CSAH-36 Eastbound					Int. Total
	Left	Thru	Right	Peds	App. Total	Left	Thru	Right	Peds	App. Total	Left	Thru	Right	Peds	App. Total	Left	Thru	Right	Peds	App. Total	
Peak Hour Analysis From 15:00 to 17:45 - Peak 1 of 1																					
Peak Hour for Entire Intersection Begins at 16:00																					
16:00	3	27	7	0	37	2	4	26	0	32	8	20	4	0	32	10	3	1	1	15	116
16:15	7	25	11	1	44	3	5	14	0	22	4	29	3	0	36	12	2	4	0	18	120
16:30	4	30	8	0	42	1	6	19	0	26	4	23	0	2	29	4	1	0	2	7	104
16:45	5	27	8	0	40	4	4	21	0	29	5	26	2	2	35	11	5	6	0	22	126
Total Volume	19	109	34	1	163	10	19	80	0	109	21	98	9	4	132	37	11	11	3	62	466
% App. Total	11.7	66.9	20.9	0.6		9.2	17.4	73.4	0		15.9	74.2	6.8	3		59.7	17.7	17.7	4.8		
PHF	.679	.908	.773	.250	.926	.625	.792	.769	.000	.852	.656	.845	.563	.500	.917	.771	.550	.458	.375	.705	.925

