



Minnesota Dept. of Transportation

Traffic Data Collection -Metro

TH-252 AT 85TH AVE N
 Ref.Pt; 003.236
 Jamar # T-2638 CAH
 TURN MOVEMENT COUNT

File Name : TH-252 AT 85TH AVE N
 Site Code : 003.236
 Start Date : 1/15/2013
 Page No : 1

Groups Printed- Unshifted

Start Time	TH-252 Southbound				85TH AVE N Westbound				TH-252 Northbound				85TH AVE N Eastbound				Int. Total
	Right	Thru	Left	Peds	Right	Thru	Left	Peds	Right	Thru	Left	Peds	Right	Thru	Left	Peds	
06:00	12	563	5	0	7	8	10	0	3	108	12	0	68	6	24	0	826
06:15	29	678	5	0	17	10	9	0	10	177	14	0	84	3	20	1	1057
06:30	21	651	8	0	25	16	20	0	11	226	18	0	106	5	27	0	1134
06:45	18	711	3	0	31	11	13	0	10	231	22	0	120	8	26	0	1204
Total	80	2603	21	0	80	45	52	0	34	742	66	0	378	22	97	1	4221
07:00	11	612	6	0	32	12	22	0	7	237	31	0	127	6	48	0	1151
07:15	25	531	7	0	31	26	19	0	11	245	25	0	93	6	26	0	1045
07:30	20	534	3	0	14	17	11	0	9	283	40	0	114	13	43	0	1101
07:45	41	614	11	0	21	23	15	0	14	282	53	0	103	7	18	0	1202
Total	97	2291	27	0	98	78	67	0	41	1047	149	0	437	32	135	0	4499
08:00	35	579	7	0	24	12	19	0	10	235	30	0	95	11	41	0	1098
08:15	44	572	13	0	18	24	13	0	11	194	38	0	58	11	22	0	1018
08:30	37	602	12	0	39	14	7	0	13	215	47	0	82	10	28	0	1106
08:45	28	499	19	0	22	22	21	0	13	180	44	0	82	12	44	0	986
Total	144	2252	51	0	103	72	60	0	47	824	159	0	317	44	135	0	4208
*** BREAK ***																	
14:45	53	253	17	0	29	22	7	0	11	483	100	0	73	35	54	0	1137
Total	53	253	17	0	29	22	7	0	11	483	100	0	73	35	54	0	1137
15:00	70	246	23	0	18	12	12	0	21	533	96	0	67	37	49	0	1184
15:15	69	305	25	0	30	22	11	0	19	674	89	0	52	26	44	0	1366
15:30	71	282	34	0	25	33	13	0	27	651	101	0	66	40	39	0	1382
15:45	70	276	24	0	29	14	12	0	11	742	115	0	61	43	68	0	1465
Total	280	1109	106	0	102	81	48	0	78	2600	401	0	246	146	200	0	5397
16:00	50	310	35	0	19	16	6	0	21	690	85	0	76	48	75	0	1431
16:15	81	322	29	0	24	28	13	0	25	805	88	0	59	28	36	1	1539
16:30	75	309	36	0	37	35	16	0	22	747	103	0	54	50	89	0	1573
16:45	73	326	33	0	47	56	18	0	18	760	118	0	66	42	66	0	1623
Total	279	1267	133	0	127	135	53	0	86	3002	394	0	255	168	266	1	6166
17:00	68	392	37	0	47	24	12	0	19	664	102	0	69	51	73	0	1558
17:15	92	338	38	0	31	36	17	0	14	748	121	0	58	39	66	0	1598
17:30	82	276	26	0	27	52	11	1	12	708	116	0	60	53	83	0	1507
17:45	79	275	24	0	42	39	9	1	27	681	109	0	38	42	59	0	1425
Total	321	1281	125	0	147	151	49	2	72	2801	448	0	225	185	281	0	6088
Grand Total	1254	11056	480	0	686	584	336	2	369	11499	1717	0	1931	632	1168	2	31716
Apprch %	9.8	86.4	3.8	0	42.7	36.3	20.9	0.1	2.7	84.6	12.6	0	51.7	16.9	31.3	0.1	
Total %	4	34.9	1.5	0	2.2	1.8	1.1	0	1.2	36.3	5.4	0	6.1	2	3.7	0	



Minnesota Dept. of Transportation

Traffic Data Collection -Metro

TH-252 AT 85TH AVE N
 Ref.Pt; 003.236
 Jamar # T-2638 CAH
 TURN MOVEMENT COUNT

File Name : TH-252 AT 85TH AVE N
 Site Code : 003.236
 Start Date : 1/15/2013
 Page No : 2

Start Time	TH-252 Southbound					85TH AVE N Westbound					TH-252 Northbound					85TH AVE N Eastbound					Int. Total
	Right	Thru	Left	Peds	App. Total	Right	Thru	Left	Peds	App. Total	Right	Thru	Left	Peds	App. Total	Right	Thru	Left	Peds	App. Total	
Peak Hour Analysis From 06:00 to 08:45 - Peak 1 of 1																					
Peak Hour for Entire Intersection Begins at 06:15																					
06:15	29	678	5	0	712	17	10	9	0	36	10	177	14	0	201	84	3	20	1	108	1057
06:30	21	651	8	0	680	25	16	20	0	61	11	226	18	0	255	106	5	27	0	138	1134
06:45	18	711	3	0	732	31	11	13	0	55	10	231	22	0	263	120	8	26	0	154	1204
07:00	11	612	6	0	629	32	12	22	0	66	7	237	31	0	275	127	6	48	0	181	1151
Total Volume	79	2652	22	0	2753	105	49	64	0	218	38	871	85	0	994	437	22	121	1	581	4546
% App. Total	2.9	96.3	0.8	0		48.2	22.5	29.4	0		3.8	87.6	8.6	0		75.2	3.8	20.8	0.2		
PHF	.681	.932	.688	.000	.940	.820	.766	.727	.000	.826	.864	.919	.685	.000	.904	.860	.688	.630	.250	.802	.944

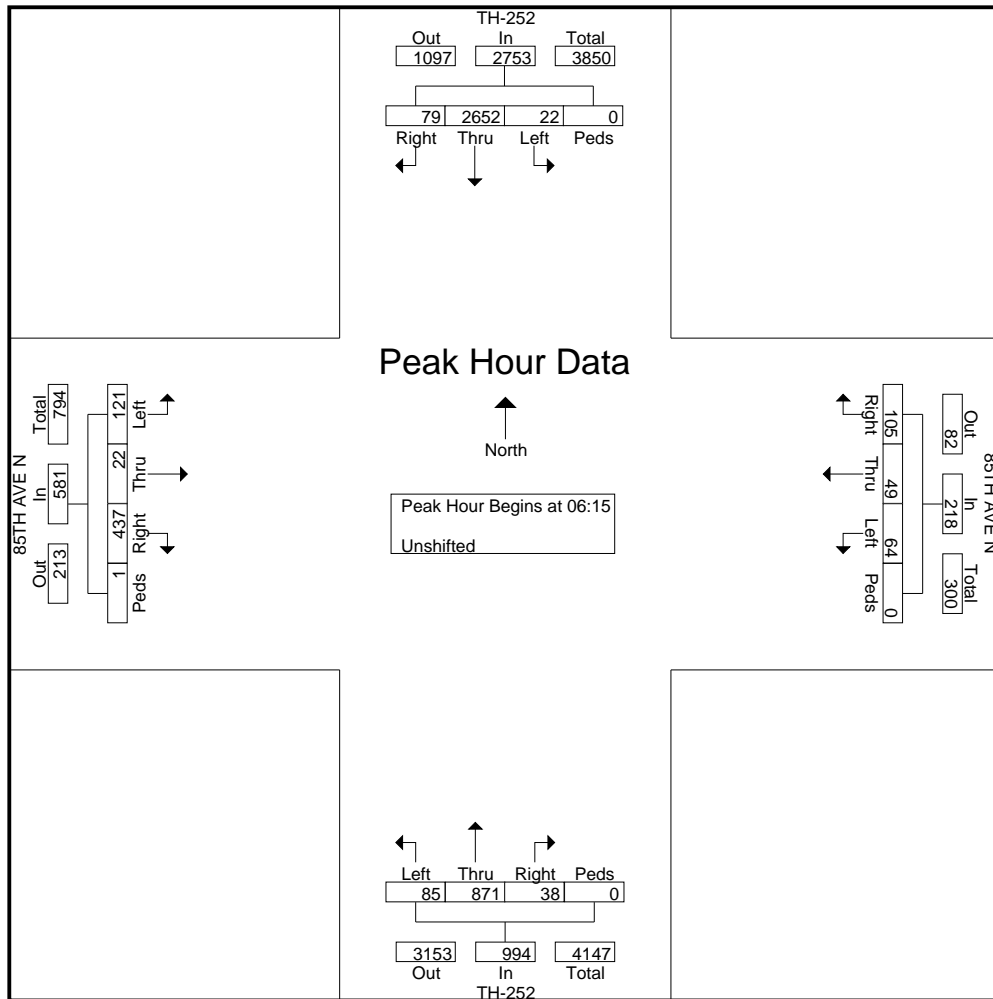



Minnesota Dept. of Transportation

Traffic Data Collection -Metro

TH-252 AT 85TH AVE N
 Ref.Pt; 003.236
 Jamar # T-2638 CAH
 TURN MOVEMENT COUNT

File Name : TH-252 AT 85TH AVE N
 Site Code : 003.236
 Start Date : 1/15/2013
 Page No : 3

Start Time	TH-252 Southbound					85TH AVE N Westbound					TH-252 Northbound					85TH AVE N Eastbound					Int. Total
	Rig ht	Thr u	Left	Ped s	App. Total	Rig ht	Thr u	Left	Ped s	App. Total	Right	Thr u	Left	Peds	App. Total	Right	Thr u	Left	Peds	App. Total	
Peak Hour Analysis From 14:45 to 17:45 - Peak 1 of 1																					
Peak Hour for Entire Intersection Begins at 16:30																					
16:30	75	309	36	0	420	37	35	16	0	88	22	747	103	0	872	54	50	89	0	193	1573
16:45	73	326	33	0	432	47	56	18	0	121	18	760	118	0	896	66	42	66	0	174	1623
17:00	68	392	37	0	497	47	24	12	0	83	19	664	102	0	785	69	51	73	0	193	1558
17:15	92	338	38	0	468	31	36	17	0	84	14	748	121	0	883	58	39	66	0	163	1598
Total Volume	308	1365	144	0	1817	162	151	63	0	376	73	2919	444	0	3436	247	182	294	0	723	6352
% App. Total	17	75.1	7.9	0		43.1	40.2	16.8	0		2.1	85	12.9	0		34.2	25.2	40.7	0		
PHF	.837	.871	.947	.000	.914	.862	.674	.875	.000	.777	.830	.960	.917	.000	.959	.895	.892	.826	.000	.937	.978

