



MINNESOTA DEPT OF TRANSPORTATION

TRAFFIC DATA COLLECTION - METRO

TH 252 @ 66th AVE N 2007
 TRAFFIC DATA INC.
 Hwy 252 & 66th Ave N
 Brooklyn Center, MN

File Name : 186712&3 - Hwy 252 & 66th Ave N
 Site Code : 00186712
 Start Date : 1/30/2007
 Page No : 1

Groups Printed- Unshifted

Start Time	TH 252 Southbound				66th AV N Westbound				TH 252 Northbound				66th AV N Eastbound				Int. Total
	Left	Thru	Right	App. Total	Left	Thru	Right	App. Total	Left	Thru	Right	App. Total	Left	Thru	Right	App. Total	
07:00	0	822	18	840	16	3	2	21	30	219	22	271	10	3	81	94	1226
07:15	0	847	23	870	15	2	0	17	38	250	3	291	9	1	64	74	1252
07:30	1	754	23	778	22	3	1	26	41	312	4	357	21	3	106	130	1291
07:45	0	794	20	814	15	3	2	20	32	258	4	294	9	1	73	83	1211
Total	1	3217	84	3302	68	11	5	84	141	1039	33	1213	49	8	324	381	4980
08:00	0	785	37	822	22	4	0	26	36	256	7	299	17	1	68	86	1233
08:15	0	822	28	850	13	3	1	17	18	238	2	258	14	2	64	80	1205
08:30	1	741	35	777	11	2	0	13	29	217	2	248	19	2	93	114	1152
08:45	1	731	31	763	9	5	1	15	35	244	2	281	9	1	65	75	1134
Total	2	3079	131	3212	55	14	2	71	118	955	13	1086	59	6	290	355	4724
*** BREAK ***																	
16:00	2	356	24	382	8	10	3	21	61	737	15	813	39	4	62	105	1321
16:15	0	400	33	433	9	5	1	15	56	774	7	837	31	1	44	76	1361
16:30	3	342	32	377	7	2	0	9	50	839	14	903	32	3	69	104	1393
16:45	3	402	39	444	6	3	0	9	57	806	18	881	40	4	65	109	1443
Total	8	1500	128	1636	30	20	4	54	224	3156	54	3434	142	12	240	394	5518
17:00	0	354	31	385	11	10	0	21	67	911	15	993	34	5	65	104	1503
17:15	0	403	45	448	8	5	0	13	74	908	18	1000	38	4	58	100	1561
17:30	1	360	24	385	5	7	1	13	63	820	11	894	28	2	53	83	1375
17:45	0	367	29	396	8	3	0	11	67	773	5	845	19	4	54	77	1329
Total	1	1484	129	1614	32	25	1	58	271	3412	49	3732	119	15	230	364	5768
Grand Total	12	9280	472	9764	185	70	12	267	754	8562	149	9465	369	41	1084	1494	20990
Apprch %	0.1	95	4.8		69.3	26.2	4.5		8	90.5	1.6		24.7	2.7	72.6		
Total %	0.1	44.2	2.2	46.5	0.9	0.3	0.1	1.3	3.6	40.8	0.7	45.1	1.8	0.2	5.2	7.1	



MINNESOTA DEPT OF TRANSPORTATION

TRAFFIC DATA COLLECTION - METRO

File Name : 186712&3 - Hwy 252 & 66th Ave N
 Site Code : 00186712
 Start Date : 1/30/2007
 Page No : 2

Start Time	TH 252 Southbound				66th AV N Westbound				TH 252 Northbound				66th AV N Eastbound				Int. Total
	Left	Thru	Right	App. Total	Left	Thru	Right	App. Total	Left	Thru	Right	App. Total	Left	Thru	Right	App. Total	
Peak Hour Analysis From 07:00 to 12:30 - Peak 1 of 1																	
Peak Hour for Entire Intersection Begins at 07:15																	
07:15	0	847	23	870	15	2	0	17	38	250	3	291	9	1	64	74	1252
07:30	1	754	23	778	22	3	1	26	41	312	4	357	21	3	106	130	1291
07:45	0	794	20	814	15	3	2	20	32	258	4	294	9	1	73	83	1211
08:00	0	785	37	822	22	4	0	26	36	256	7	299	17	1	68	86	1233
Total Volume	1	3180	103	3284	74	12	3	89	147	1076	18	1241	56	6	311	373	4987
% App. Total	0	96.8	3.1		83.1	13.5	3.4		11.8	86.7	1.5		15	1.6	83.4		
PHF	.250	.939	.696	.944	.841	.750	.375	.856	.896	.862	.643	.869	.667	.500	.733	.717	.966

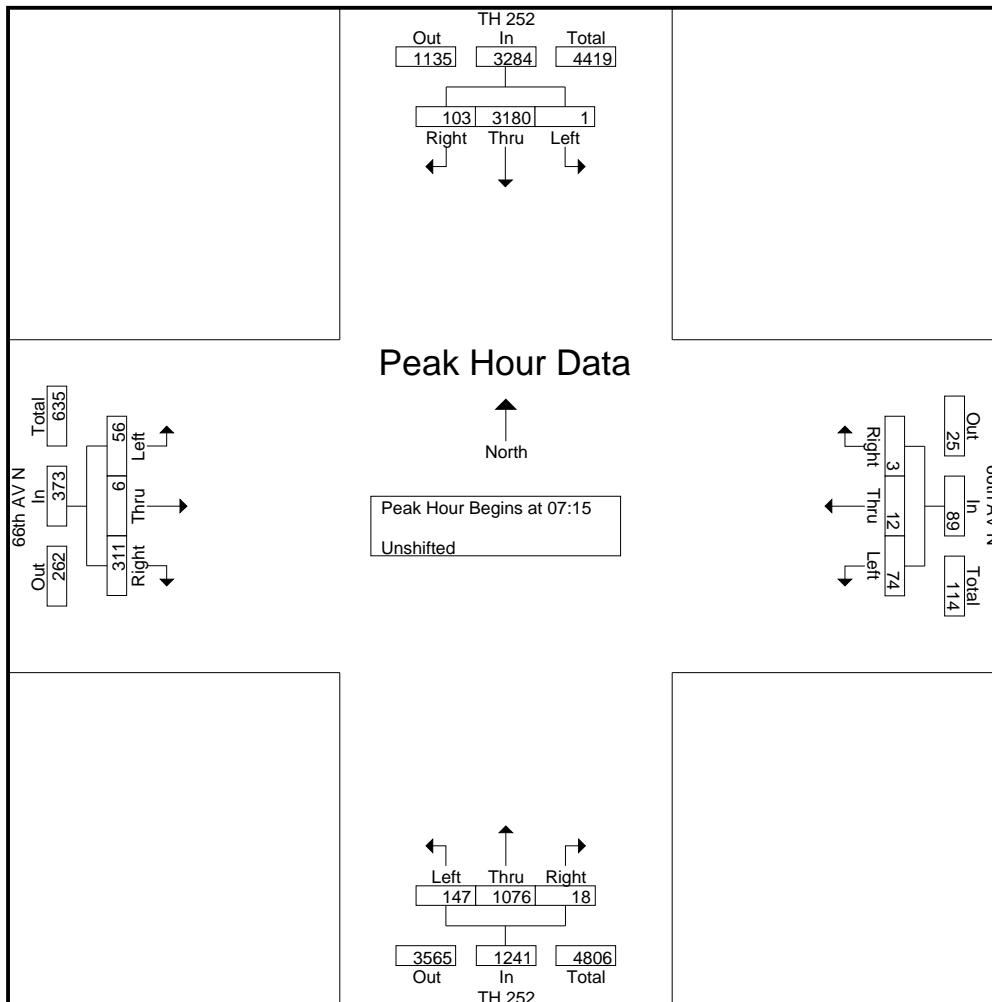



MINNESOTA DEPT OF TRANSPORTATION

TRAFFIC DATA COLLECTION - METRO

File Name : 186712&3 - Hwy 252 & 66th Ave N
 Site Code : 00186712
 Start Date : 1/30/2007
 Page No : 3

Start Time	TH 252 Southbound				66th AV N Westbound				TH 252 Northbound				66th AV N Eastbound				Int. Total
	Left	Thru	Right	App. Total	Left	Thru	Right	App. Total	Left	Thru	Right	App. Total	Left	Thru	Right	App. Total	

Peak Hour Analysis From 07:00 to 12:30 - Peak 1 of 1

Peak Hour for Each Approach Begins at:

	07:00				07:15				07:15				07:00			
+0 mins.	0	822	18	840	15	2	0	17	38	250	3	291	10	3	81	94
+15 mins.	0	847	23	870	22	3	1	26	41	312	4	357	9	1	64	74
+30 mins.	1	754	23	778	15	3	2	20	32	258	4	294	21	3	106	130
+45 mins.	0	794	20	814	22	4	0	26	36	256	7	299	9	1	73	83
Total Volume	1	3217	84	3302	74	12	3	89	147	1076	18	1241	49	8	324	381
% App. Total	0	97.4	2.5		83.1	13.5	3.4		11.8	86.7	1.5		12.9	2.1	85	
PHF	.250	.950	.913	.949	.841	.750	.375	.856	.896	.862	.643	.869	.583	.667	.764	.733

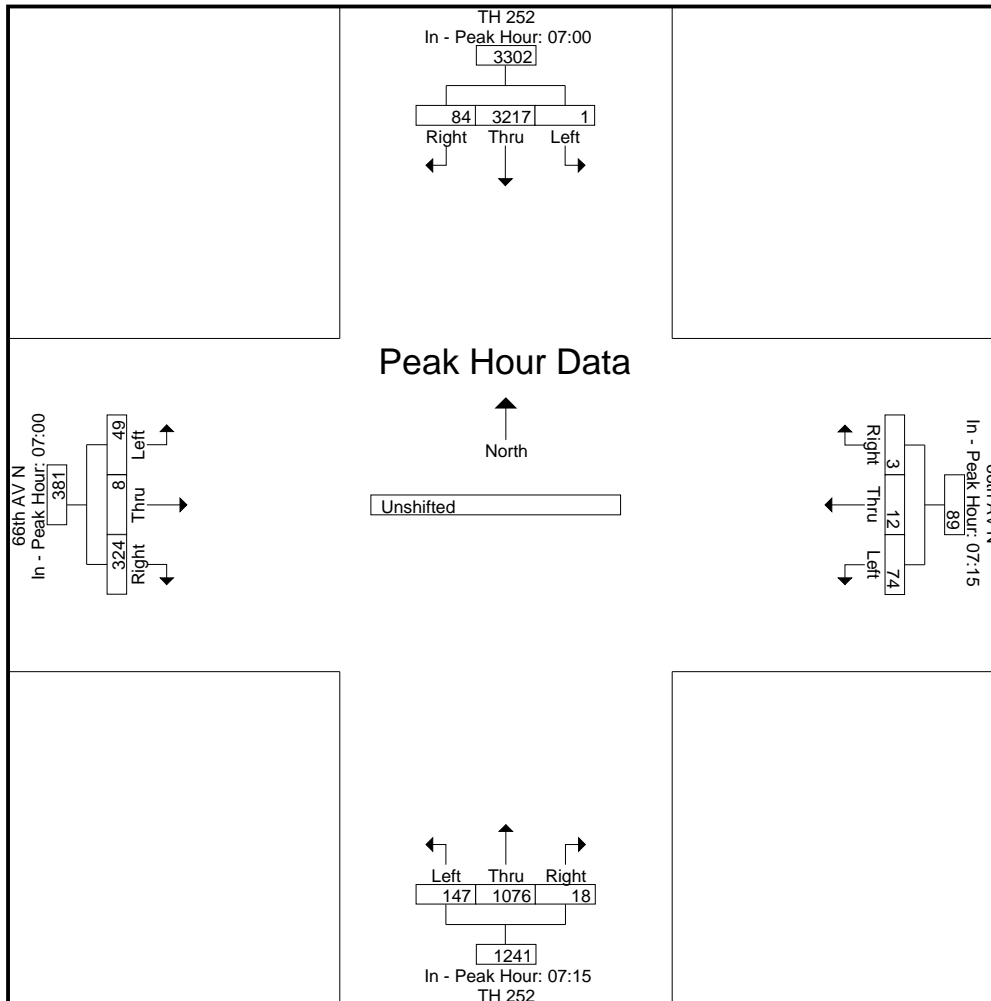



MINNESOTA DEPT OF TRANSPORTATION

TRAFFIC DATA COLLECTION - METRO

File Name : 186712&3 - Hwy 252 & 66th Ave N
 Site Code : 00186712
 Start Date : 1/30/2007
 Page No : 4

Start Time	TH 252 Southbound				66th AV N Westbound				TH 252 Northbound				66th AV N Eastbound				Int. Total
	Left	Thru	Right	App. Total	Left	Thru	Right	App. Total	Left	Thru	Right	App. Total	Left	Thru	Right	App. Total	
Peak Hour Analysis From 12:45 to 17:45 - Peak 1 of 1																	
Peak Hour for Entire Intersection Begins at 16:30																	
16:30	3	342	32	377	7	2	0	9	50	839	14	903	32	3	69	104	1393
16:45	3	402	39	444	6	3	0	9	57	806	18	881	40	4	65	109	1443
17:00	0	354	31	385	11	10	0	21	67	911	15	993	34	5	65	104	1503
17:15	0	403	45	448	8	5	0	13	74	908	18	1000	38	4	58	100	1561
Total Volume	6	1501	147	1654	32	20	0	52	248	3464	65	3777	144	16	257	417	5900
% App. Total	0.4	90.7	8.9		61.5	38.5	0		6.6	91.7	1.7		34.5	3.8	61.6		
PHF	.500	.931	.817	.923	.727	.500	.000	.619	.838	.951	.903	.944	.900	.800	.931	.956	.945

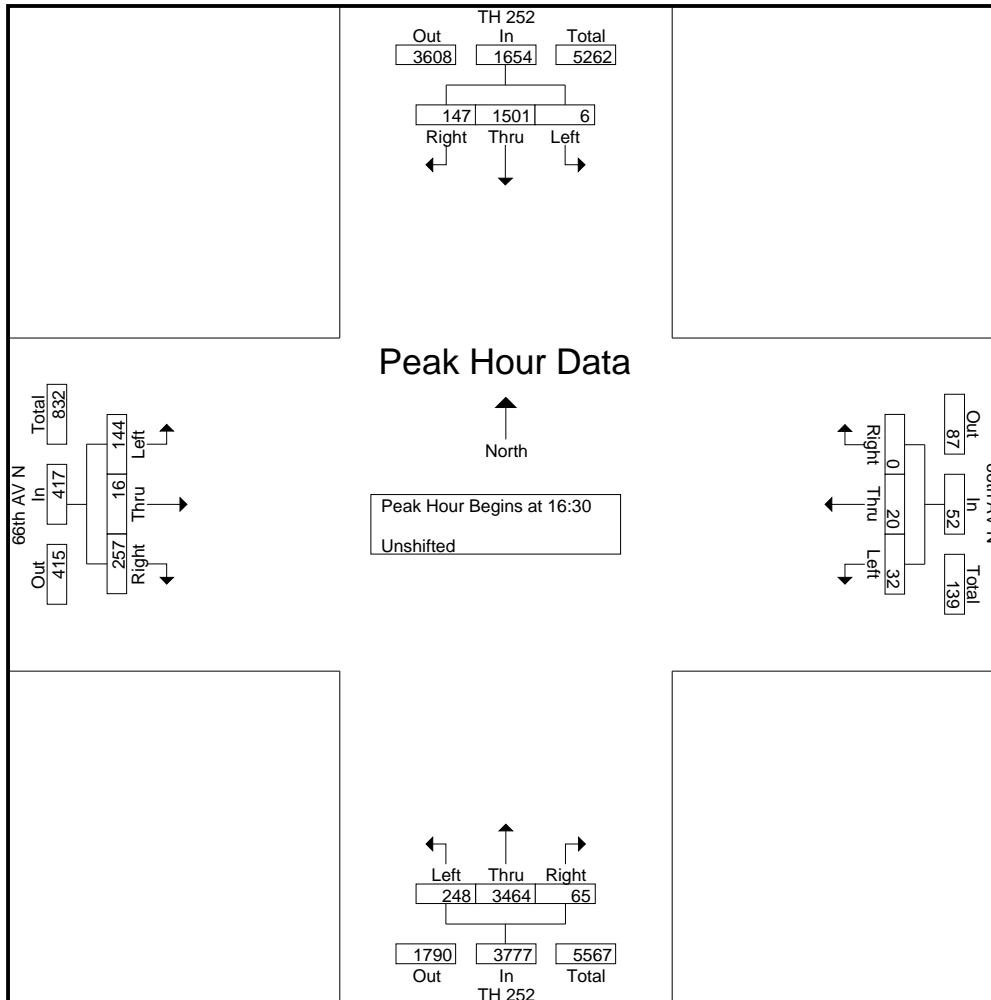



MINNESOTA DEPT OF TRANSPORTATION

TRAFFIC DATA COLLECTION - METRO

File Name : 186712&3 - Hwy 252 & 66th Ave N
 Site Code : 00186712
 Start Date : 1/30/2007
 Page No : 5

Start Time	TH 252 Southbound				66th AV N Westbound				TH 252 Northbound				66th AV N Eastbound				Int. Total
	Left	Thru	Right	App. Total	Left	Thru	Right	App. Total	Left	Thru	Right	App. Total	Left	Thru	Right	App. Total	
Peak Hour Analysis From 12:45 to 17:45 - Peak 1 of 1																	
Peak Hour for Each Approach Begins at:																	
	16:45				17:00				16:30				16:30				
+0 mins.	3	402	39	444	11	10	0	21	50	839	14	903	32	3	69	104	
+15 mins.	0	354	31	385	8	5	0	13	57	806	18	881	40	4	65	109	
+30 mins.	0	403	45	448	5	7	1	13	67	911	15	993	34	5	65	104	
+45 mins.	1	360	24	385	8	3	0	11	74	908	18	1000	38	4	58	100	
Total Volume	4	1519	139	1662	32	25	1	58	248	3464	65	3777	144	16	257	417	
% App. Total	0.2	91.4	8.4		55.2	43.1	1.7		6.6	91.7	1.7		34.5	3.8	61.6		
PHF	.333	.942	.772	.927	.727	.625	.250	.690	.838	.951	.903	.944	.900	.800	.931	.956	

