



# MINNESOTA DEPT OF TRANSPORTATION

## TRAFFIC DATA COLLECTION - METRO

TH-25 / Ash Ave. at 4th St NE    MAYER  
 Ref.Pt.: 033.780  
 JAMAR # T-2638            CAH  
 TURN MOVEMENT COUNT

File Name : TH-25 at 4th St NE MAYER 2010  
 Site Code : 00000000  
 Start Date : 10/27/2010  
 Page No : 1

**Groups Printed- Cars & Trucks**

Start Time	TH-25 / ASH AVE N. Southbound				4th ST NE Westbound				TH-25 / ASH AVE N. Northbound				4th ST NE Eastbound				Int. Total
	Left	Thru	Right	Peds	Left	Thru	Right	Peds	Left	Thru	Right	Peds	Left	Thru	Right	Peds	
06:00	1	9	0	0	3	1	5	0	0	19	0	0	0	0	0	0	38
06:15	0	9	0	0	2	0	3	0	0	42	2	0	0	0	0	0	58
06:30	0	13	0	0	1	0	2	0	0	25	0	0	0	0	0	0	41
06:45	2	8	0	0	2	1	2	0	0	35	0	0	0	1	0	0	51
<b>Total</b>	<b>3</b>	<b>39</b>	<b>0</b>	<b>0</b>	<b>8</b>	<b>2</b>	<b>12</b>	<b>0</b>	<b>0</b>	<b>121</b>	<b>2</b>	<b>0</b>	<b>0</b>	<b>1</b>	<b>0</b>	<b>0</b>	<b>188</b>
07:00	1	17	0	0	7	0	6	0	1	41	2	0	2	0	1	0	78
07:15	0	16	0	0	5	0	6	0	0	48	1	0	0	0	0	0	76
07:30	0	17	1	0	5	0	5	0	0	49	0	0	0	0	1	0	78
07:45	1	33	0	0	2	0	10	0	1	79	2	0	0	0	0	0	128
<b>Total</b>	<b>2</b>	<b>83</b>	<b>1</b>	<b>0</b>	<b>19</b>	<b>0</b>	<b>27</b>	<b>0</b>	<b>2</b>	<b>217</b>	<b>5</b>	<b>0</b>	<b>2</b>	<b>0</b>	<b>2</b>	<b>0</b>	<b>360</b>
08:00	1	39	0	0	2	0	3	0	2	76	1	0	0	0	3	0	127
08:15	2	28	0	0	1	0	4	0	0	32	1	0	0	0	0	0	68
08:30	0	18	1	0	2	0	0	0	0	31	1	0	0	1	1	0	55
08:45	0	9	0	0	1	1	1	0	0	16	1	0	0	0	2	0	31
<b>Total</b>	<b>3</b>	<b>94</b>	<b>1</b>	<b>0</b>	<b>6</b>	<b>1</b>	<b>8</b>	<b>0</b>	<b>2</b>	<b>155</b>	<b>4</b>	<b>0</b>	<b>0</b>	<b>1</b>	<b>6</b>	<b>0</b>	<b>281</b>
*** BREAK ***																	
15:00	6	50	0	0	1	1	2	0	0	24	3	0	0	1	0	0	88
15:15	3	39	0	0	1	0	1	0	2	27	0	0	0	0	1	0	74
15:30	1	26	0	0	2	1	1	0	0	18	5	0	0	0	1	0	55
15:45	6	42	0	0	3	1	2	0	0	25	6	0	0	0	0	0	85
<b>Total</b>	<b>16</b>	<b>157</b>	<b>0</b>	<b>0</b>	<b>7</b>	<b>3</b>	<b>6</b>	<b>0</b>	<b>2</b>	<b>94</b>	<b>14</b>	<b>0</b>	<b>0</b>	<b>1</b>	<b>2</b>	<b>0</b>	<b>302</b>
16:00	5	45	1	0	2	0	2	0	1	26	4	0	0	0	0	0	86
16:15	5	32	0	0	2	0	4	0	0	30	3	0	0	1	0	0	77
16:30	7	43	0	0	4	2	3	0	0	29	3	0	0	0	2	0	93
16:45	4	51	0	0	4	1	3	0	0	37	9	0	0	0	0	0	109
<b>Total</b>	<b>21</b>	<b>171</b>	<b>1</b>	<b>0</b>	<b>12</b>	<b>3</b>	<b>12</b>	<b>0</b>	<b>1</b>	<b>122</b>	<b>19</b>	<b>0</b>	<b>0</b>	<b>1</b>	<b>2</b>	<b>0</b>	<b>365</b>
17:00	4	37	0	0	0	0	0	0	0	34	4	0	1	1	0	0	81
17:15	5	50	0	0	3	0	3	0	0	32	6	0	0	0	0	0	99
17:30	5	55	0	2	8	0	2	0	1	40	8	0	0	0	2	0	123
17:45	7	43	1	0	1	0	1	0	1	34	5	0	0	0	0	0	93
<b>Total</b>	<b>21</b>	<b>185</b>	<b>1</b>	<b>2</b>	<b>12</b>	<b>0</b>	<b>6</b>	<b>0</b>	<b>2</b>	<b>140</b>	<b>23</b>	<b>0</b>	<b>1</b>	<b>1</b>	<b>2</b>	<b>0</b>	<b>396</b>
<b>Grand Total</b>	<b>66</b>	<b>729</b>	<b>4</b>	<b>2</b>	<b>64</b>	<b>9</b>	<b>71</b>	<b>0</b>	<b>9</b>	<b>849</b>	<b>67</b>	<b>0</b>	<b>3</b>	<b>5</b>	<b>14</b>	<b>0</b>	<b>1892</b>
Apprch %	8.2	91	0.5	0.2	44.4	6.2	49.3	0	1	91.8	7.2	0	13.6	22.7	63.6	0	
Total %	3.5	38.5	0.2	0.1	3.4	0.5	3.8	0	0.5	44.9	3.5	0	0.2	0.3	0.7	0	



# MINNESOTA DEPT OF TRANSPORTATION

## TRAFFIC DATA COLLECTION - METRO

TH-25 / Ash Ave. at 4th St NE    MAYER  
 Ref.Pt.: 033.780  
 JAMAR # T-2638            CAH  
 TURN MOVEMENT COUNT

File Name : TH-25 at 4th St NE MAYER 2010  
 Site Code : 00000000  
 Start Date : 10/27/2010  
 Page No : 2

Start Time	TH-25 / ASH AVE N. Southbound					4th ST NE Westbound					TH-25 / ASH AVE N. Northbound					4th ST NE Eastbound					Int. Total
	Left	Thru	Right	Peds	App. Total	Left	Thru	Right	Peds	App. Total	Left	Thru	Right	Peds	App. Total	Left	Thru	Right	Peds	App. Total	
Peak Hour Analysis From 06:00 to 08:45 - Peak 1 of 1																					
Peak Hour for Entire Intersection Begins at 07:15																					
07:15	0	16	0	0	16	5	0	6	0	11	0	48	1	0	49	0	0	0	0	0	76
07:30	0	17	1	0	18	5	0	5	0	10	0	49	0	0	49	0	0	1	0	1	78
07:45	1	33	0	0	34	2	0	10	0	12	1	79	2	0	82	0	0	0	0	0	128
08:00	1	39	0	0	40	2	0	3	0	5	2	76	1	0	79	0	0	3	0	3	127
Total Volume	2	105	1	0	108	14	0	24	0	38	3	252	4	0	259	0	0	4	0	4	409
% App. Total	1.9	97.2	0.9	0		36.8	0	63.2	0		1.2	97.3	1.5	0		0	0	100	0		
PHF	.500	.673	.250	.000	.675	.700	.000	.600	.000	.792	.375	.797	.500	.000	.790	.000	.000	.333	.000	.333	.799

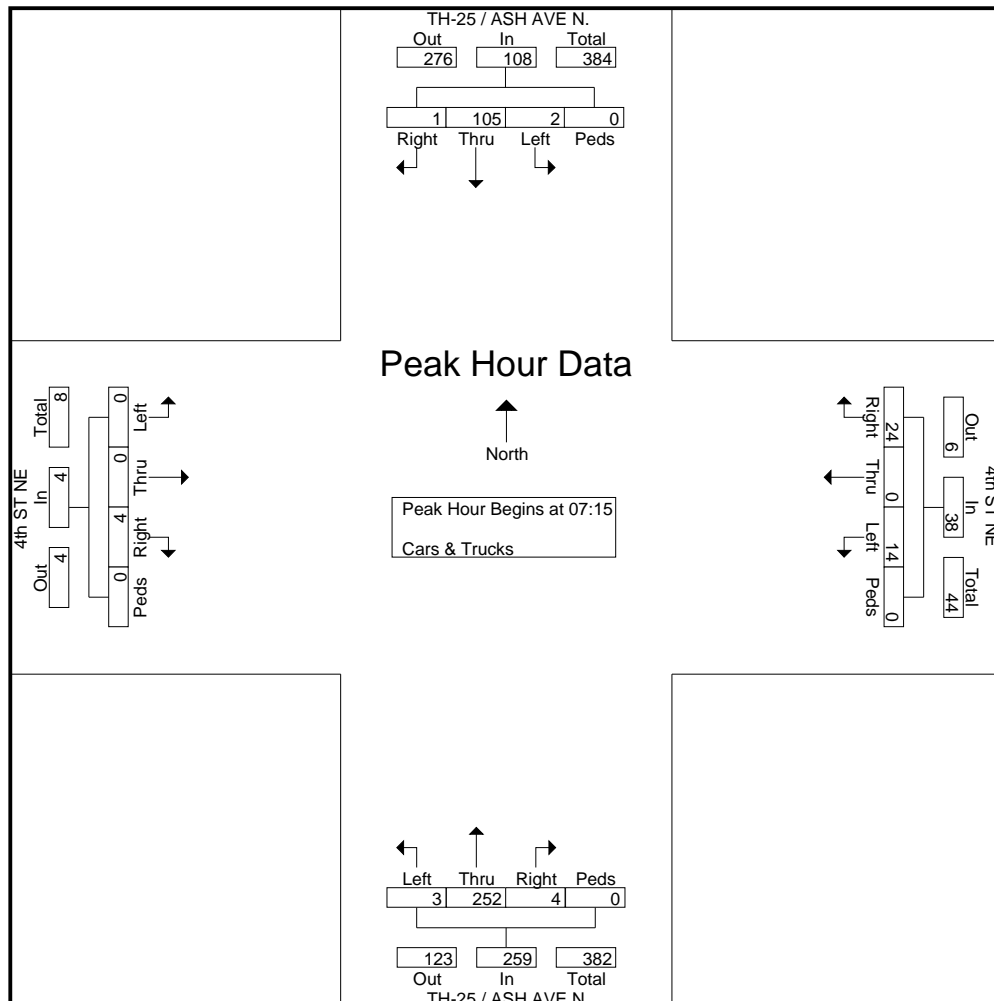



# MINNESOTA DEPT OF TRANSPORTATION

## TRAFFIC DATA COLLECTION - METRO

TH-25 / Ash Ave. at 4th St NE    MAYER  
 Ref.Pt.: 033.780  
 JAMAR # T-2638            CAH  
 TURN MOVEMENT COUNT

File Name : TH-25 at 4th St NE MAYER 2010  
 Site Code : 00000000  
 Start Date : 10/27/2010  
 Page No : 3

Start Time	TH-25 / ASH AVE N. Southbound					4th ST NE Westbound					TH-25 / ASH AVE N. Northbound					4th ST NE Eastbound					Int. Total
	Left	Thru	Right	Peds	App. Total	Left	Thru	Right	Peds	App. Total	Left	Thru	Right	Peds	App. Total	Left	Thru	Right	Peds	App. Total	

Peak Hour Analysis From 15:00 to 17:45 - Peak 1 of 1  
 Peak Hour for Entire Intersection Begins at 16:45

16:45	4	51	0	0	55	4	1	3	0	8	0	37	9	0	46	0	0	0	0	0	109
17:00	4	37	0	0	41	0	0	0	0	0	0	34	4	0	38	1	1	0	0	2	81
17:15	5	50	0	0	55	3	0	3	0	6	0	32	6	0	38	0	0	0	0	0	99
17:30	5	55	0	2	62	8	0	2	0	10	1	40	8	0	49	0	0	2	0	2	123
Total Volume	18	193	0	2	213	15	1	8	0	24	1	143	27	0	171	1	1	2	0	4	412
% App. Total	8.5	90.6	0	0.9		62.5	4.2	33.3	0		0.6	83.6	15.8	0		25	25	50	0		
PHF	.900	.877	.000	.250	.859	.469	.250	.667	.000	.600	.250	.894	.750	.000	.872	.250	.250	.250	.000	.500	.837

