

Alliant Engineering Inc Minneapolis, MN 55415

Flying Cloud Drive at Regional Center Rd
Eden Prairie
data by: Alliant Engineering
TURN MOVEMENT COUNT

File Name : 07_Flying Cloud Drive at Regional Center Road
Site Code : 00000007
Start Date : 10/7/2009
Page No : 1

Groups Printed- Unshifted - Bank 1

Start Time	Flying Cloud Drive (TH 212) Southbound				mall entrance Westbound				Flying Cloud Drive (TH 212) Northbound				Regional Center Road Eastbound				Int. Total
	Left	Thru	Right	Peds	Left	Thru	Right	Peds	Left	Thru	Right	Peds	Left	Thru	Right	Peds	
06:30	10	76	8	0	3	3	14	1	0	127	7	0	2	3	1	1	256
06:45	17	99	7	0	0	3	14	0	5	187	18	0	4	5	0	0	359
Total	27	175	15	0	3	6	28	1	5	314	25	0	6	8	1	1	615
07:00	12	82	10	0	1	0	19	0	4	241	24	0	8	3	2	0	406
07:15	15	140	11	0	6	1	23	0	1	318	18	0	5	3	2	0	543
07:30	14	128	8	0	3	6	20	0	12	315	27	0	11	8	0	0	552
07:45	19	139	5	0	12	8	30	0	5	344	24	0	8	5	2	0	601
Total	60	489	34	0	22	15	92	0	22	1218	93	0	32	19	6	0	2102
08:00	16	128	15	0	9	3	14	0	7	272	22	0	15	4	2	0	507
08:15	20	114	10	0	7	7	22	1	7	207	26	0	6	3	3	0	433
08:30	20	134	10	2	4	9	13	3	6	196	25	0	15	12	4	1	454
08:45	17	98	11	1	5	9	31	1	6	185	26	0	11	16	1	0	418
Total	73	474	46	3	25	28	80	5	26	860	99	0	47	35	10	1	1812
09:00	10	94	11	0	8	9	20	0	6	162	26	0	14	7	1	0	368
09:15	16	124	8	0	6	6	24	0	5	131	23	0	9	11	2	0	365
*** BREAK ***																	
Total	26	218	19	0	14	15	44	0	11	293	49	0	23	18	3	0	733
*** BREAK ***																	
10:30	20	99	9	0	4	5	30	0	11	132	32	0	14	10	2	0	368
10:45	23	100	18	0	11	15	18	0	4	128	31	0	15	6	2	0	371
Total	43	199	27	0	15	20	48	0	15	260	63	0	29	16	4	0	739
11:00	24	143	19	0	11	15	22	0	5	153	31	0	17	9	5	0	454
11:15	28	122	18	0	9	13	27	1	12	174	57	0	14	24	5	0	504
11:30	37	182	16	0	11	16	25	0	13	202	68	0	16	12	7	0	605
11:45	45	188	23	0	22	15	41	0	9	186	60	0	27	31	12	0	659
Total	134	635	76	0	53	59	115	1	39	715	216	0	74	76	29	0	2222
12:00	38	205	22	1	15	19	58	0	16	177	39	0	13	24	3	1	631
12:15	41	191	18	0	19	26	46	0	14	184	53	0	33	24	2	0	651
12:30	48	174	16	0	20	24	56	0	6	192	41	0	42	34	8	0	661
12:45	28	189	22	0	27	31	46	0	14	221	40	0	23	19	12	0	672
Total	155	759	78	1	81	100	206	0	50	774	173	0	111	101	25	1	2615
13:00	37	156	13	0	24	27	58	0	12	172	46	0	40	22	5	0	612
13:15	26	139	11	0	22	34	49	0	4	177	28	0	47	23	4	2	566
*** BREAK ***																	
Total	63	295	24	0	46	61	107	0	16	349	74	0	87	45	9	2	1178
*** BREAK ***																	
14:30	22	132	13	0	17	26	23	0	2	133	24	1	21	16	2	0	432
14:45	21	173	13	0	11	10	37	0	3	166	22	0	18	13	2	0	489
Total	43	305	26	0	28	36	60	0	5	299	46	1	39	29	4	0	921
15:00	10	169	8	0	18	29	33	0	6	158	27	1	31	16	7	0	513
15:15	17	151	13	0	15	19	38	1	6	141	33	0	21	17	4	1	477
15:30	17	180	8	1	10	18	30	1	5	150	28	1	15	21	6	1	492
15:45	10	219	14	1	13	15	21	1	6	134	24	1	9	15	8	0	491
Total	54	719	43	2	56	81	122	3	23	583	112	3	76	69	25	2	1973
16:00	16	216	14	0	23	18	19	1	7	138	26	0	13	15	9	1	516
16:15	20	206	13	1	19	19	23	1	4	137	28	1	21	14	4	0	511
16:30	13	267	26	0	13	16	36	0	13	150	32	0	17	13	7	0	603
16:45	23	298	18	0	17	23	15	1	9	179	39	0	20	20	11	0	673
Total	72	987	71	1	72	76	93	3	33	604	125	1	71	62	31	1	2303

Alliant Engineering Inc Minneapolis, MN 55415

Flying Cloud Drive at Regional Center Rd
Eden Prairie
data by: Alliant Engineering
TURN MOVEMENT COUNT

File Name : 07_Flying Cloud Drive at Regional Center Road
Site Code : 00000007
Start Date : 10/7/2009
Page No : 2

Groups Printed- Unshifted - Bank 1

Start Time	Flying Cloud Drive (TH 212) Southbound				mall entrance Westbound				Flying Cloud Drive (TH 212) Northbound				Regional Center Road Eastbound				Int. Total
	Left	Thru	Right	Peds	Left	Thru	Right	Peds	Left	Thru	Right	Peds	Left	Thru	Right	Peds	
17:00	24	291	19	0	23	26	17	0	5	164	38	0	25	27	10	0	669
17:15	29	315	15	0	22	22	26	0	11	163	44	0	20	13	12	0	692
17:30	24	307	24	0	15	20	31	2	9	179	48	2	16	12	9	2	700
17:45	34	254	24	0	16	20	20	0	10	133	42	0	13	12	7	0	585
Total	111	1167	82	0	76	88	94	2	35	639	172	2	74	64	38	2	2646
18:00	31	233	11	0	15	20	20	0	6	158	45	1	21	12	11	1	585
18:15	21	180	21	0	15	15	29	0	10	149	36	0	24	15	8	0	523
18:30	8	168	12	2	23	16	30	2	6	144	55	0	18	19	7	0	510
18:45	32	164	6	1	18	20	25	1	6	143	38	1	12	13	6	3	489
Total	92	745	50	3	71	71	104	3	28	594	174	2	75	59	32	4	2107
Grand Total	953	7167	591	10	562	656	1193	18	308	7502	1421	9	744	601	217	14	21966
Apprch %	10.9	82.2	6.8	0.1	23.1	27	49.1	0.7	3.3	81.2	15.4	0.1	47.2	38.1	13.8	0.9	
Total %	4.3	32.6	2.7	0	2.6	3	5.4	0.1	1.4	34.2	6.5	0	3.4	2.7	1	0.1	
Unshifted	952	7108	582	10	560	653	1188	18	304	7397	1414	9	734	600	212	14	21755
% Unshifted	99.9	99.2	98.5	100	99.6	99.5	99.6	100	98.7	98.6	99.5	100	98.7	99.8	97.7	100	99
Bank 1	1	59	9	0	2	3	5	0	4	105	7	0	10	1	5	0	211
% Bank 1	0.1	0.8	1.5	0	0.4	0.5	0.4	0	1.3	1.4	0.5	0	1.3	0.2	2.3	0	1

Alliant Engineering Inc Minneapolis, MN 55415

Flying Cloud Drive at Regional Center Rd
Eden Prairie
data by: Alliant Engineering
TURN MOVEMENT COUNT

File Name : 07_Flying Cloud Drive at Regional Center Road
Site Code : 00000007
Start Date : 10/7/2009
Page No : 3

Start Time	Flying Cloud Drive (TH 212) Southbound					mall entrance Westbound					Flying Cloud Drive (TH 212) Northbound					Regional Center Road Eastbound					Int. Total
	Left	Thru	Right	Peds	App. Total	Left	Thru	Right	Peds	App. Total	Left	Thru	Right	Peds	App. Total	Left	Thru	Right	Peds	App. Total	
Peak Hour Analysis From 06:30 to 09:15 - Peak 1 of 1																					
Peak Hour for Entire Intersection Begins at 07:15																					
07:15	15	140	11	0	166	6	1	23	0	30	1	318	18	0	337	5	3	2	0	10	543
07:30	14	128	8	0	150	3	6	20	0	29	12	315	27	0	354	11	8	0	0	19	552
07:45	19	139	5	0	163	12	8	30	0	50	5	344	24	0	373	8	5	2	0	15	601
08:00	16	128	15	0	159	9	3	14	0	26	7	272	22	0	301	15	4	2	0	21	507
Total Volume	64	535	39	0	638	30	18	87	0	135	25	1249	91	0	1365	39	20	6	0	65	2203
% App. Total	10	83.9	6.1	0		22.2	13.3	64.4	0		1.8	91.5	6.7	0		60	30.8	9.2	0		
PHF	.842	.955	.650	.000	.961	.625	.563	.725	.000	.675	.521	.908	.843	.000	.915	.650	.625	.750	.000	.774	.916

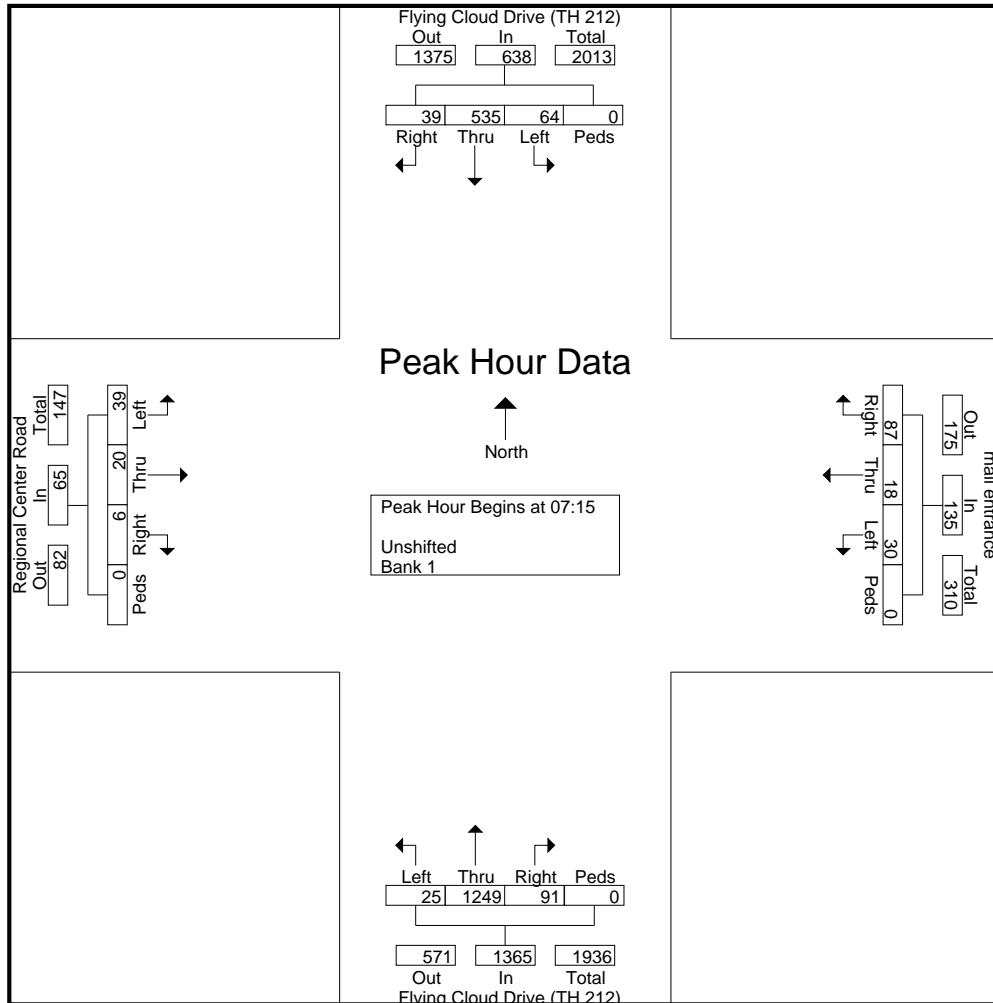

Alliant Engineering Inc Minneapolis, MN 55415

Flying Cloud Drive at Regional Center Rd
Eden Prairie
data by: Alliant Engineering
TURN MOVEMENT COUNT

File Name : 07_Flying Cloud Drive at Regional Center Road
Site Code : 00000007
Start Date : 10/7/2009
Page No : 4

Start Time	Flying Cloud Drive (TH 212) Southbound					mall entrance Westbound					Flying Cloud Drive (TH 212) Northbound					Regional Center Road Eastbound					Int. Total
	Left	Thru	Right	Peds	App. Total	Left	Thru	Right	Peds	App. Total	Left	Thru	Right	Peds	App. Total	Left	Thru	Right	Peds	App. Total	
Peak Hour Analysis From 15:00 to 18:45 - Peak 1 of 1																					
Peak Hour for Entire Intersection Begins at 16:45																					
16:45	23	298	18	0	339	17	23	15	1	56	9	179	39	0	227	20	20	11	0	51	673
17:00	24	291	19	0	334	23	26	17	0	66	5	164	38	0	207	25	27	10	0	62	669
17:15	29	315	15	0	359	22	22	26	0	70	11	163	44	0	218	20	13	12	0	45	692
17:30	24	307	24	0	355	15	20	31	2	68	9	179	48	2	238	16	12	9	2	39	700
Total Volume	100	1211	76	0	1387	77	91	89	3	260	34	685	169	2	890	81	72	42	2	197	2734
% App. Total	7.2	87.3	5.5	0		29.6	35	34.2	1.2		3.8	77	19	0.2		41.1	36.5	21.3	1		
PHF	.862	.961	.792	.000	.966	.837	.875	.718	.375	.929	.773	.957	.880	.250	.935	.810	.667	.875	.250	.794	.976

