

Alliant Engineering, Inc.

733 Marquette Ave #700, Minneapolis, MN 55402

Technology Dr & Southwest Station

File Name : 23_EP_Technology Dr at Southwest Station

Ref Pt:

Site Code :

data by: Alliant Inc

Start Date : 12/22/2020

TURN MOVEMENT COUNT

Page No : 1

Groups Printed- Cars - Trucks

Start Time	Southwest Station Southbound					Technology Dr Westbound					N/A Northbound					Technology Dr Eastbound					Int. Total
	Right	Thru	Left	Peds	App. Total	Right	Thru	Left	Peds	App. Total	Right	Thru	Left	Peds	App. Total	Right	Thru	Left	Peds	App. Total	
06:00 AM	0	0	2	0	2	2	5	0	0	7	0	0	0	0	0	0	6	1	0	7	16
06:15 AM	1	0	4	0	5	1	12	0	0	13	0	0	0	0	0	0	3	0	0	3	21
06:30 AM	2	0	0	0	2	5	13	0	0	18	0	0	0	0	0	0	11	1	0	12	32
06:45 AM	0	0	3	0	3	7	10	0	0	17	0	0	0	0	0	0	11	1	0	12	32
Total	3	0	9	0	12	15	40	0	0	55	0	0	0	0	0	0	31	3	0	34	101
07:00 AM	0	0	6	0	6	8	19	0	0	27	0	0	0	0	0	0	7	2	0	9	42
07:15 AM	2	0	2	0	4	7	17	0	0	24	0	0	0	0	0	0	10	1	0	11	39
07:30 AM	1	0	4	0	5	4	18	0	0	22	0	0	0	0	0	0	16	1	0	17	44
07:45 AM	1	0	1	0	2	6	16	0	0	22	0	0	0	0	0	0	11	1	0	12	36
Total	4	0	13	0	17	25	70	0	0	95	0	0	0	0	0	0	44	5	0	49	161
08:00 AM	0	0	7	1	8	6	15	0	0	21	0	0	0	0	0	0	23	3	0	26	55
08:15 AM	1	0	8	0	9	9	17	0	0	26	0	0	0	0	0	0	22	1	1	24	59
08:30 AM	0	0	3	0	3	6	13	0	1	20	0	0	0	0	0	0	20	1	0	21	44
08:45 AM	1	0	7	1	9	4	19	0	0	23	0	0	0	0	0	0	20	2	0	22	54
Total	2	0	25	2	29	25	64	0	1	90	0	0	0	0	0	0	85	7	1	93	212
09:00 AM	2	0	6	1	9	7	12	0	0	19	0	0	0	0	0	0	25	1	0	26	54
09:15 AM	0	0	8	1	9	1	17	0	0	18	0	0	0	0	0	0	22	1	1	24	51
*** BREAK ***																					
Total	2	0	14	2	18	8	29	0	0	37	0	0	0	0	0	0	47	2	1	50	105
*** BREAK ***																					
10:30 AM	3	0	19	0	22	11	26	0	1	38	0	0	0	0	0	0	29	5	0	34	94
10:45 AM	3	0	15	0	18	13	17	0	0	30	0	0	0	0	0	0	33	3	2	38	86
Total	6	0	34	0	40	24	43	0	1	68	0	0	0	0	0	0	62	8	2	72	180
11:00 AM	4	0	18	1	23	25	23	0	0	48	0	0	0	0	0	0	52	4	0	56	127
11:15 AM	6	0	20	0	26	23	25	0	0	48	0	0	0	0	0	0	37	11	0	48	122
11:30 AM	12	0	29	1	42	44	30	0	0	74	0	0	0	0	0	0	41	13	0	54	170
11:45 AM	9	0	29	0	38	33	23	0	0	56	0	0	0	0	0	0	35	11	0	46	140
Total	31	0	96	2	129	125	101	0	0	226	0	0	0	0	0	0	165	39	0	204	559
12:00 PM	13	0	30	0	43	49	36	0	0	85	0	0	0	0	0	0	45	10	0	55	183
12:15 PM	19	0	34	0	53	45	30	0	0	75	0	0	0	0	0	0	39	14	0	53	181
12:30 PM	11	0	38	1	50	38	36	0	0	74	0	0	0	0	0	0	39	9	1	49	173
12:45 PM	7	0	40	0	47	47	31	0	0	78	0	0	0	0	0	0	31	5	0	36	161
Total	50	0	142	1	193	179	133	0	0	312	0	0	0	0	0	0	154	38	1	193	698
01:00 PM	9	0	29	0	38	35	28	0	0	63	0	0	0	0	0	0	37	2	1	40	141
01:15 PM	7	0	29	0	36	29	27	0	2	58	0	0	0	0	0	0	44	3	0	47	141
*** BREAK ***																					
Total	16	0	58	0	74	64	55	0	2	121	0	0	0	0	0	0	81	5	1	87	282
*** BREAK ***																					
02:30 PM	9	0	24	0	33	22	21	0	0	43	0	0	0	0	0	0	32	4	0	36	112
02:45 PM	11	0	21	0	32	34	23	0	2	59	0	0	0	0	0	0	38	6	1	45	136
Total	20	0	45	0	65	56	44	0	2	102	0	0	0	0	0	0	70	10	1	81	248
03:00 PM	5	0	22	1	28	20	30	0	0	50	0	0	0	0	0	0	49	6	0	55	133
03:15 PM	8	0	22	0	30	28	23	0	1	52	0	0	0	0	0	0	42	2	0	44	126
03:30 PM	4	0	26	0	30	19	17	0	0	36	0	0	0	0	0	0	39	2	1	42	108
03:45 PM	6	0	18	0	24	31	29	0	0	60	0	0	0	0	0	0	61	2	0	63	147
Total	23	0	88	1	112	98	99	0	1	198	0	0	0	0	0	0	191	12	1	204	514
04:00 PM	7	0	14	0	21	18	26	0	0	44	0	0	0	0	0	0	40	2	4	46	111

Alliant Engineering, Inc.

733 Marquette Ave #700, Minneapolis, MN 55402

Technology Dr & Southwest Station

File Name : 23_EP_Technology Dr at Southwest Station

Ref Pt:

Site Code :

data by: Alliant Inc

Start Date : 12/22/2020

TURN MOVEMENT COUNT

Page No : 2

Groups Printed- Cars - Trucks

Start Time	Southwest Station Southbound					Technology Dr Westbound					N/A Northbound					Technology Dr Eastbound					Int. Total
	Right	Thru	Left	Peds	App. Total	Right	Thru	Left	Peds	App. Total	Right	Thru	Left	Peds	App. Total	Right	Thru	Left	Peds	App. Total	
04:15 PM	4	0	20	0	24	22	36	0	0	58	0	0	0	0	0	0	48	7	0	55	137
04:30 PM	8	0	16	1	25	28	34	0	0	62	0	0	0	0	0	0	45	6	0	51	138
04:45 PM	5	0	23	0	28	20	32	0	0	52	0	0	0	0	0	0	46	5	1	52	132
Total	24	0	73	1	98	88	128	0	0	216	0	0	0	0	0	0	179	20	5	204	518
05:00 PM	9	0	17	0	26	32	46	0	0	78	0	0	0	0	0	0	42	4	0	46	150
05:15 PM	12	0	29	0	41	48	39	0	0	87	0	0	0	0	0	0	33	9	0	42	170
05:30 PM	12	0	33	0	45	48	23	0	0	71	0	0	0	0	0	0	32	0	0	32	148
05:45 PM	4	0	36	0	40	46	36	0	0	82	0	0	0	0	0	0	27	8	0	35	157
Total	37	0	115	0	152	174	144	0	0	318	0	0	0	0	0	0	134	21	0	155	625
Grand Total	218	0	712	9	939	881	950	0	7	1838	0	0	0	0	0	0	1243	170	13	1426	4203
Apprch %	23.2	0	75.8	1		47.9	51.7	0	0.4		0	0	0	0	0	0	87.2	11.9	0.9		
Total %	5.2	0	16.9	0.2	22.3	21	22.6	0	0.2	43.7	0	0	0	0	0	0	29.6	4	0.3	33.9	
Cars	211	0	704	9	924	872	917	0	7	1796	0	0	0	0	0	0	1201	165	13	1379	4099
% Cars	96.8	0	98.9	100	98.4	99	96.5	0	100	97.7	0	0	0	0	0	0	96.6	97.1	100	96.7	97.5
Trucks	7	0	8	0	15	9	33	0	0	42	0	0	0	0	0	0	42	5	0	47	104
% Trucks	3.2	0	1.1	0	1.6	1	3.5	0	0	2.3	0	0	0	0	0	0	3.4	2.9	0	3.3	2.5

Alliant Engineering, Inc.

733 Marquette Ave #700, Minneapolis, MN 55402

Technology Dr & Southwest Station
 Ref Pt:
 data by: Alliant Inc
 TURN MOVEMENT COUNT

File Name : 23_EP_Technology Dr at Southwest Station
 Site Code :
 Start Date : 12/22/2020
 Page No : 3

Start Time	Southwest Station Southbound					Technology Dr Westbound					N/A Northbound					Technology Dr Eastbound					Int. Total
	Right	Thru	Left	Peds	App. Total	Right	Thru	Left	Peds	App. Total	Right	Thru	Left	Peds	App. Total	Right	Thru	Left	Peds	App. Total	
Peak Hour Analysis From 06:00 AM to 09:45 AM - Peak 1 of 1																					
Peak Hour for Entire Intersection Begins at 08:00 AM																					
08:00 AM	0	0	7	1	8	6	15	0	0	21	0	0	0	0	0	0	23	3	0	26	55
08:15 AM	1	0	8	0	9	9	17	0	0	26	0	0	0	0	0	0	22	1	1	24	59
08:30 AM	0	0	3	0	3	6	13	0	1	20	0	0	0	0	0	0	20	1	0	21	44
08:45 AM	1	0	7	1	9	4	19	0	0	23	0	0	0	0	0	0	20	2	0	22	54
Total Volume	2	0	25	2	29	25	64	0	1	90	0	0	0	0	0	0	85	7	1	93	212
% App. Total	6.9	0	86.2	6.9		27.8	71.1	0	1.1		0	0	0	0		0	91.4	7.5	1.1		
PHF	.500	.000	.781	.500	.806	.694	.842	.000	.250	.865	.000	.000	.000	.000	.000	.000	.924	.583	.250	.894	.898

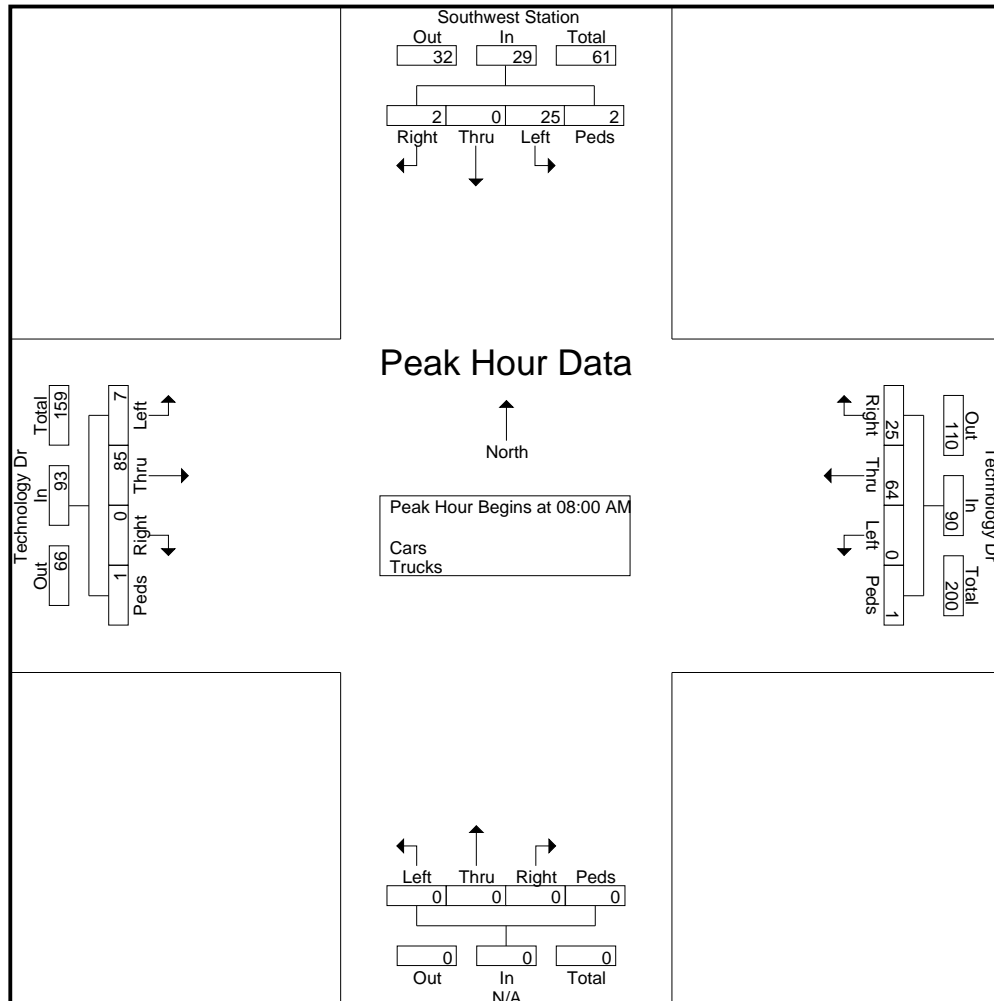

Alliant Engineering, Inc.

733 Marquette Ave #700, Minneapolis, MN 55402

Technology Dr & Southwest Station
 Ref Pt:
 data by: Alliant Inc
 TURN MOVEMENT COUNT

File Name : 23_EP_Technology Dr at Southwest Station
 Site Code :
 Start Date : 12/22/2020
 Page No : 4

Start Time	Southwest Station Southbound					Technology Dr Westbound					N/A Northbound					Technology Dr Eastbound					Int. Total
	Right	Thru	Left	Peds	App. Total	Right	Thru	Left	Peds	App. Total	Right	Thru	Left	Peds	App. Total	Right	Thru	Left	Peds	App. Total	
Peak Hour Analysis From 10:00 AM to 01:45 PM - Peak 1 of 1																					
Peak Hour for Entire Intersection Begins at 12:00 PM																					
12:00 PM	13	0	30	0	43	49	36	0	0	85	0	0	0	0	0	0	45	10	0	55	183
12:15 PM	19	0	34	0	53	45	30	0	0	75	0	0	0	0	0	0	39	14	0	53	181
12:30 PM	11	0	38	1	50	38	36	0	0	74	0	0	0	0	0	0	39	9	1	49	173
12:45 PM	7	0	40	0	47	47	31	0	0	78	0	0	0	0	0	0	31	5	0	36	161
Total Volume	50	0	142	1	193	179	133	0	0	312	0	0	0	0	0	0	154	38	1	193	698
% App. Total	25.9	0	73.6	0.5		57.4	42.6	0	0		0	0	0	0		0	79.8	19.7	0.5		
PHF	.658	.000	.888	.250	.910	.913	.924	.000	.000	.918	.000	.000	.000	.000	.000	.000	.856	.679	.250	.877	.954

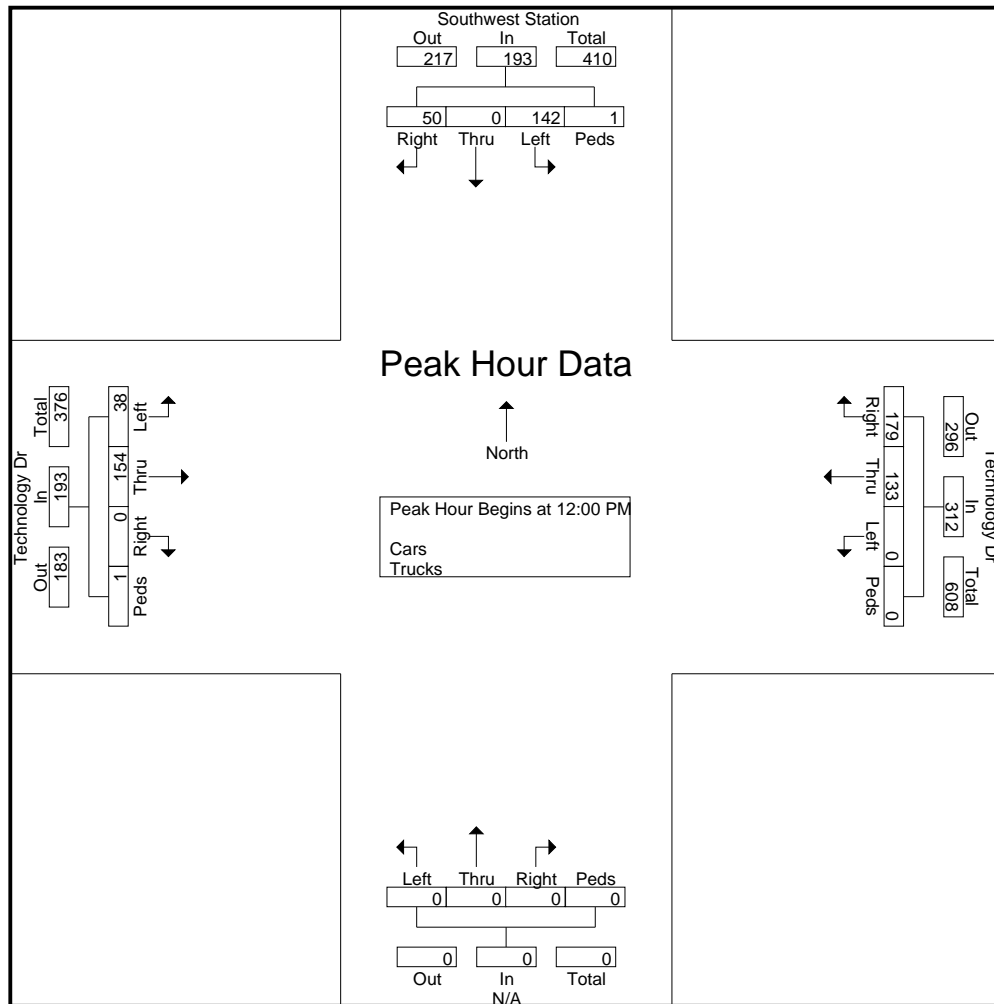

Alliant Engineering, Inc.

733 Marquette Ave #700, Minneapolis, MN 55402

Technology Dr & Southwest Station
 Ref Pt:
 data by: Alliant Inc
 TURN MOVEMENT COUNT

File Name : 23_EP_Technology Dr at Southwest Station
 Site Code :
 Start Date : 12/22/2020
 Page No : 5

Start Time	Southwest Station Southbound					Technology Dr Westbound					N/A Northbound					Technology Dr Eastbound					Int. Total
	Right	Thru	Left	Peds	App. Total	Right	Thru	Left	Peds	App. Total	Right	Thru	Left	Peds	App. Total	Right	Thru	Left	Peds	App. Total	
Peak Hour Analysis From 02:00 PM to 05:45 PM - Peak 1 of 1																					
Peak Hour for Entire Intersection Begins at 05:00 PM																					
05:00 PM	9	0	17	0	26	32	46	0	0	78	0	0	0	0	0	0	42	4	0	46	150
05:15 PM	12	0	29	0	41	48	39	0	0	87	0	0	0	0	0	0	33	9	0	42	170
05:30 PM	12	0	33	0	45	48	23	0	0	71	0	0	0	0	0	0	32	0	0	32	148
05:45 PM	4	0	36	0	40	46	36	0	0	82	0	0	0	0	0	0	27	8	0	35	157
Total Volume	37	0	115	0	152	174	144	0	0	318	0	0	0	0	0	0	134	21	0	155	625
% App. Total	24.3	0	75.7	0		54.7	45.3	0	0		0	0	0	0	0	0	86.5	13.5	0		
PHF	.771	.000	.799	.000	.844	.906	.783	.000	.000	.914	.000	.000	.000	.000	.000	.000	.798	.583	.000	.842	.919

