

Alliant Engineering, Inc.

733 Marquette Ave #700, Minneapolis, MN 55402

Prairie Center Dr & W 78th St
 Ref Pt:
 data by: Alliant Inc
 TURN MOVEMENT COUNT

File Name : 17_EP_Prairie Center Dr at W 78th St
 Site Code :
 Start Date : 12/8/2020
 Page No : 1

Groups Printed- Cars - Trucks

| Start Time | Prairie Center Dr Southbound | | | | | W 78th St Westbound | | | | | Prairie Center Dr Northbound | | | | | W 78th St Eastbound | | | | | Int. Total |
|---------------|------------------------------|------|------|------|------------|---------------------|------|------|------|------------|------------------------------|------|------|------|------------|---------------------|------|------|------|------------|------------|
| | Right | Thru | Left | Peds | App. Total | Right | Thru | Left | Peds | App. Total | Right | Thru | Left | Peds | App. Total | Right | Thru | Left | Peds | App. Total | |
| 06:00 AM | 10 | 30 | 0 | 0 | 40 | 1 | 2 | 1 | 0 | 4 | 3 | 13 | 2 | 0 | 18 | 2 | 0 | 5 | 1 | 8 | 70 |
| 06:15 AM | 13 | 20 | 2 | 0 | 35 | 0 | 1 | 0 | 0 | 1 | 0 | 33 | 4 | 0 | 37 | 2 | 1 | 4 | 1 | 8 | 81 |
| 06:30 AM | 7 | 24 | 1 | 0 | 32 | 0 | 5 | 1 | 0 | 6 | 5 | 39 | 3 | 0 | 47 | 2 | 3 | 4 | 0 | 9 | 94 |
| 06:45 AM | 22 | 45 | 0 | 0 | 67 | 0 | 2 | 4 | 0 | 6 | 5 | 48 | 2 | 0 | 55 | 5 | 2 | 7 | 0 | 14 | 142 |
| Total | 52 | 119 | 3 | 0 | 174 | 1 | 10 | 6 | 0 | 17 | 13 | 133 | 11 | 0 | 157 | 11 | 6 | 20 | 2 | 39 | 387 |
| 07:00 AM | 15 | 37 | 2 | 0 | 54 | 1 | 6 | 4 | 0 | 11 | 5 | 30 | 4 | 1 | 40 | 5 | 3 | 14 | 0 | 22 | 127 |
| 07:15 AM | 18 | 29 | 2 | 0 | 49 | 0 | 4 | 2 | 0 | 6 | 5 | 60 | 5 | 0 | 70 | 5 | 3 | 5 | 0 | 13 | 138 |
| 07:30 AM | 11 | 47 | 9 | 0 | 67 | 0 | 7 | 1 | 1 | 9 | 8 | 70 | 6 | 0 | 84 | 2 | 6 | 7 | 0 | 15 | 175 |
| 07:45 AM | 19 | 53 | 16 | 0 | 88 | 2 | 1 | 2 | 0 | 5 | 16 | 77 | 6 | 0 | 99 | 3 | 7 | 10 | 0 | 20 | 212 |
| Total | 63 | 166 | 29 | 0 | 258 | 3 | 18 | 9 | 1 | 31 | 34 | 237 | 21 | 1 | 293 | 15 | 19 | 36 | 0 | 70 | 652 |
| 08:00 AM | 22 | 58 | 23 | 1 | 104 | 0 | 8 | 6 | 1 | 15 | 12 | 66 | 6 | 0 | 84 | 4 | 8 | 8 | 0 | 20 | 223 |
| 08:15 AM | 23 | 58 | 10 | 0 | 91 | 2 | 5 | 4 | 0 | 11 | 6 | 68 | 6 | 0 | 80 | 7 | 11 | 11 | 0 | 29 | 211 |
| 08:30 AM | 19 | 51 | 9 | 0 | 79 | 1 | 6 | 1 | 0 | 8 | 13 | 68 | 5 | 0 | 86 | 4 | 10 | 0 | 0 | 14 | 187 |
| 08:45 AM | 19 | 70 | 7 | 0 | 96 | 4 | 10 | 10 | 0 | 24 | 2 | 49 | 7 | 0 | 58 | 5 | 2 | 7 | 0 | 14 | 192 |
| Total | 83 | 237 | 49 | 1 | 370 | 7 | 29 | 21 | 1 | 58 | 33 | 251 | 24 | 0 | 308 | 20 | 31 | 26 | 0 | 77 | 813 |
| 09:00 AM | 42 | 78 | 7 | 0 | 127 | 3 | 8 | 5 | 0 | 16 | 6 | 50 | 5 | 0 | 61 | 9 | 7 | 15 | 0 | 31 | 235 |
| 09:15 AM | 22 | 53 | 4 | 0 | 79 | 4 | 9 | 8 | 0 | 21 | 11 | 49 | 4 | 0 | 64 | 4 | 7 | 19 | 0 | 30 | 194 |
| *** BREAK *** | | | | | | | | | | | | | | | | | | | | | |
| Total | 64 | 131 | 11 | 0 | 206 | 7 | 17 | 13 | 0 | 37 | 17 | 99 | 9 | 0 | 125 | 13 | 14 | 34 | 0 | 61 | 429 |
| *** BREAK *** | | | | | | | | | | | | | | | | | | | | | |
| 10:30 AM | 44 | 83 | 4 | 0 | 131 | 3 | 15 | 9 | 0 | 27 | 2 | 72 | 14 | 0 | 88 | 20 | 3 | 22 | 0 | 45 | 291 |
| 10:45 AM | 54 | 95 | 5 | 0 | 154 | 5 | 13 | 13 | 0 | 31 | 10 | 75 | 16 | 0 | 101 | 16 | 1 | 18 | 0 | 35 | 321 |
| Total | 98 | 178 | 9 | 0 | 285 | 8 | 28 | 22 | 0 | 58 | 12 | 147 | 30 | 0 | 189 | 36 | 4 | 40 | 0 | 80 | 612 |
| 11:00 AM | 48 | 90 | 3 | 1 | 142 | 1 | 23 | 14 | 0 | 38 | 8 | 65 | 15 | 0 | 88 | 10 | 11 | 27 | 0 | 48 | 316 |
| 11:15 AM | 49 | 106 | 7 | 0 | 162 | 0 | 19 | 9 | 0 | 28 | 5 | 69 | 11 | 0 | 85 | 16 | 12 | 24 | 0 | 52 | 327 |
| 11:30 AM | 42 | 118 | 2 | 0 | 162 | 4 | 21 | 25 | 0 | 50 | 11 | 82 | 15 | 0 | 108 | 18 | 12 | 31 | 0 | 61 | 381 |
| 11:45 AM | 53 | 129 | 3 | 0 | 185 | 6 | 16 | 15 | 0 | 37 | 15 | 93 | 11 | 0 | 119 | 11 | 14 | 32 | 0 | 57 | 398 |
| Total | 192 | 443 | 15 | 1 | 651 | 11 | 79 | 63 | 0 | 153 | 39 | 309 | 52 | 0 | 400 | 55 | 49 | 114 | 0 | 218 | 1422 |
| 12:00 PM | 69 | 138 | 1 | 0 | 208 | 11 | 25 | 20 | 0 | 56 | 12 | 115 | 15 | 0 | 142 | 19 | 18 | 29 | 0 | 66 | 472 |
| 12:15 PM | 59 | 121 | 4 | 0 | 184 | 9 | 29 | 17 | 0 | 55 | 14 | 109 | 15 | 0 | 138 | 19 | 17 | 41 | 0 | 77 | 454 |
| 12:30 PM | 44 | 123 | 5 | 2 | 174 | 2 | 21 | 14 | 1 | 38 | 16 | 127 | 19 | 0 | 162 | 19 | 21 | 35 | 1 | 76 | 450 |
| 12:45 PM | 43 | 111 | 12 | 0 | 166 | 4 | 21 | 12 | 0 | 37 | 13 | 112 | 22 | 0 | 147 | 27 | 18 | 31 | 0 | 76 | 426 |
| Total | 215 | 493 | 22 | 2 | 732 | 26 | 96 | 63 | 1 | 186 | 55 | 463 | 71 | 0 | 589 | 84 | 74 | 136 | 1 | 295 | 1802 |
| 01:00 PM | 55 | 119 | 7 | 4 | 185 | 2 | 11 | 15 | 1 | 29 | 16 | 135 | 23 | 0 | 174 | 15 | 16 | 30 | 1 | 62 | 450 |
| 01:15 PM | 42 | 101 | 5 | 1 | 149 | 6 | 21 | 15 | 1 | 43 | 12 | 115 | 17 | 0 | 144 | 17 | 21 | 35 | 0 | 73 | 409 |
| *** BREAK *** | | | | | | | | | | | | | | | | | | | | | |
| Total | 97 | 220 | 12 | 5 | 334 | 8 | 32 | 30 | 2 | 72 | 28 | 250 | 40 | 0 | 318 | 32 | 37 | 65 | 1 | 135 | 859 |
| *** BREAK *** | | | | | | | | | | | | | | | | | | | | | |
| 02:30 PM | 47 | 95 | 3 | 0 | 145 | 3 | 12 | 4 | 0 | 19 | 4 | 106 | 18 | 0 | 128 | 20 | 13 | 38 | 1 | 72 | 364 |
| 02:45 PM | 44 | 103 | 3 | 0 | 150 | 3 | 10 | 13 | 0 | 26 | 4 | 90 | 17 | 0 | 111 | 13 | 9 | 31 | 1 | 54 | 341 |
| Total | 91 | 198 | 6 | 0 | 295 | 6 | 22 | 17 | 0 | 45 | 8 | 196 | 35 | 0 | 239 | 33 | 22 | 69 | 2 | 126 | 705 |
| 03:00 PM | 28 | 58 | 2 | 0 | 88 | 1 | 5 | 11 | 0 | 17 | 3 | 64 | 5 | 0 | 72 | 12 | 6 | 24 | 0 | 42 | 219 |
| *** BREAK *** | | | | | | | | | | | | | | | | | | | | | |
| 03:30 PM | 23 | 48 | 0 | 0 | 71 | 1 | 1 | 4 | 0 | 6 | 4 | 47 | 5 | 0 | 56 | 10 | 2 | 10 | 0 | 22 | 155 |
| 03:45 PM | 54 | 128 | 2 | 0 | 184 | 3 | 13 | 15 | 0 | 31 | 11 | 87 | 13 | 0 | 111 | 25 | 9 | 30 | 0 | 64 | 390 |
| Total | 105 | 234 | 4 | 0 | 343 | 5 | 19 | 30 | 0 | 54 | 18 | 198 | 23 | 0 | 239 | 47 | 17 | 64 | 0 | 128 | 764 |
| 04:00 PM | 57 | 127 | 5 | 0 | 189 | 2 | 15 | 15 | 0 | 32 | 9 | 105 | 23 | 0 | 137 | 27 | 15 | 20 | 2 | 64 | 422 |

Alliant Engineering, Inc.

733 Marquette Ave #700, Minneapolis, MN 55402

Prairie Center Dr & W 78th St
 Ref Pt:
 data by: Alliant Inc
 TURN MOVEMENT COUNT

File Name : 17_EP_Prairie Center Dr at W 78th St
 Site Code :
 Start Date : 12/8/2020
 Page No : 2

Groups Printed- Cars - Trucks

| Start Time | Prairie Center Dr Southbound | | | | | W 78th St Westbound | | | | | Prairie Center Dr Northbound | | | | | W 78th St Eastbound | | | | | Int. Total |
|-------------|------------------------------|------|------|------|------------|---------------------|------|------|------|------------|------------------------------|------|------|------|------------|---------------------|------|------|------|------------|------------|
| | Right | Thru | Left | Peds | App. Total | Right | Thru | Left | Peds | App. Total | Right | Thru | Left | Peds | App. Total | Right | Thru | Left | Peds | App. Total | |
| 04:15 PM | 56 | 107 | 3 | 0 | 166 | 4 | 15 | 15 | 0 | 34 | 8 | 123 | 23 | 0 | 154 | 26 | 6 | 42 | 0 | 74 | 428 |
| 04:30 PM | 60 | 128 | 4 | 0 | 192 | 7 | 16 | 13 | 0 | 36 | 6 | 98 | 18 | 0 | 122 | 18 | 7 | 37 | 2 | 64 | 414 |
| 04:45 PM | 74 | 120 | 2 | 0 | 196 | 7 | 22 | 18 | 0 | 47 | 10 | 99 | 22 | 0 | 131 | 31 | 8 | 35 | 0 | 74 | 448 |
| Total | 247 | 482 | 14 | 0 | 743 | 20 | 68 | 61 | 0 | 149 | 33 | 425 | 86 | 0 | 544 | 102 | 36 | 134 | 4 | 276 | 1712 |
| 05:00 PM | 51 | 144 | 3 | 0 | 198 | 19 | 16 | 19 | 0 | 54 | 9 | 102 | 14 | 0 | 125 | 22 | 10 | 30 | 1 | 63 | 440 |
| 05:15 PM | 57 | 120 | 3 | 0 | 180 | 22 | 23 | 29 | 0 | 74 | 8 | 141 | 13 | 0 | 162 | 34 | 22 | 42 | 0 | 98 | 514 |
| 05:30 PM | 50 | 110 | 1 | 0 | 161 | 12 | 18 | 14 | 0 | 44 | 5 | 83 | 31 | 0 | 119 | 33 | 11 | 41 | 0 | 85 | 409 |
| 05:45 PM | 44 | 112 | 0 | 0 | 156 | 10 | 13 | 9 | 0 | 32 | 4 | 77 | 35 | 1 | 117 | 38 | 8 | 38 | 0 | 84 | 389 |
| Total | 202 | 486 | 7 | 0 | 695 | 63 | 70 | 71 | 0 | 204 | 26 | 403 | 93 | 1 | 523 | 127 | 51 | 151 | 1 | 330 | 1752 |
| Grand Total | 1509 | 3387 | 181 | 9 | 5086 | 165 | 488 | 406 | 5 | 1064 | 316 | 3111 | 495 | 2 | 3924 | 575 | 360 | 889 | 11 | 1835 | 11909 |
| Apprch % | 29.7 | 66.6 | 3.6 | 0.2 | | 15.5 | 45.9 | 38.2 | 0.5 | | 8.1 | 79.3 | 12.6 | 0.1 | | 31.3 | 19.6 | 48.4 | 0.6 | | |
| Total % | 12.7 | 28.4 | 1.5 | 0.1 | 42.7 | 1.4 | 4.1 | 3.4 | 0 | 8.9 | 2.7 | 26.1 | 4.2 | 0 | 32.9 | 4.8 | 3 | 7.5 | 0.1 | 15.4 | |
| Cars | 1482 | 3334 | 177 | 9 | 5002 | 160 | 484 | 401 | 5 | 1050 | 307 | 3050 | 489 | 2 | 3848 | 570 | 358 | 882 | 9 | 1819 | 11719 |
| % Cars | 98.2 | 98.4 | 97.8 | 100 | 98.3 | 97 | 99.2 | 98.8 | 100 | 98.7 | 97.2 | 98 | 98.8 | 100 | 98.1 | 99.1 | 99.4 | 99.2 | 81.8 | 99.1 | 98.4 |
| Trucks | 27 | 53 | 4 | 0 | 84 | 5 | 4 | 5 | 0 | 14 | 9 | 61 | 6 | 0 | 76 | 5 | 2 | 7 | 2 | 16 | 190 |
| % Trucks | 1.8 | 1.6 | 2.2 | 0 | 1.7 | 3 | 0.8 | 1.2 | 0 | 1.3 | 2.8 | 2 | 1.2 | 0 | 1.9 | 0.9 | 0.6 | 0.8 | 18.2 | 0.9 | 1.6 |

Alliant Engineering, Inc.

733 Marquette Ave #700, Minneapolis, MN 55402

Prairie Center Dr & W 78th St
 Ref Pt:
 data by: Alliant Inc
 TURN MOVEMENT COUNT

File Name : 17_EP_Prairie Center Dr at W 78th St
 Site Code :
 Start Date : 12/8/2020
 Page No : 3

| Start Time | Prairie Center Dr Southbound | | | | | W 78th St Westbound | | | | | Prairie Center Dr Northbound | | | | | W 78th St Eastbound | | | | | Int. Total |
|--|------------------------------|------|------|------|------------|---------------------|------|------|------|------------|------------------------------|------|------|------|------------|---------------------|------|------|------|------------|------------|
| | Right | Thru | Left | Peds | App. Total | Right | Thru | Left | Peds | App. Total | Right | Thru | Left | Peds | App. Total | Right | Thru | Left | Peds | App. Total | |
| Peak Hour Analysis From 06:00 AM to 09:45 AM - Peak 1 of 1 | | | | | | | | | | | | | | | | | | | | | |
| Peak Hour for Entire Intersection Begins at 07:45 AM | | | | | | | | | | | | | | | | | | | | | |
| 07:45 AM | 19 | 53 | 16 | 0 | 88 | 2 | 1 | 2 | 0 | 5 | 16 | 77 | 6 | 0 | 99 | 3 | 7 | 10 | 0 | 20 | 212 |
| 08:00 AM | 22 | 58 | 23 | 1 | 104 | 0 | 8 | 6 | 1 | 15 | 12 | 66 | 6 | 0 | 84 | 4 | 8 | 8 | 0 | 20 | 223 |
| 08:15 AM | 23 | 58 | 10 | 0 | 91 | 2 | 5 | 4 | 0 | 11 | 6 | 68 | 6 | 0 | 80 | 7 | 11 | 11 | 0 | 29 | 211 |
| 08:30 AM | 19 | 51 | 9 | 0 | 79 | 1 | 6 | 1 | 0 | 8 | 13 | 68 | 5 | 0 | 86 | 4 | 10 | 0 | 0 | 14 | 187 |
| Total Volume | 83 | 220 | 58 | 1 | 362 | 5 | 20 | 13 | 1 | 39 | 47 | 279 | 23 | 0 | 349 | 18 | 36 | 29 | 0 | 83 | 833 |
| % App. Total | 22.9 | 60.8 | 16 | 0.3 | | 12.8 | 51.3 | 33.3 | 2.6 | | 13.5 | 79.9 | 6.6 | 0 | | 21.7 | 43.4 | 34.9 | 0 | | |
| PHF | .902 | .948 | .630 | .250 | .870 | .625 | .625 | .542 | .250 | .650 | .734 | .906 | .958 | .000 | .881 | .643 | .818 | .659 | .000 | .716 | .934 |

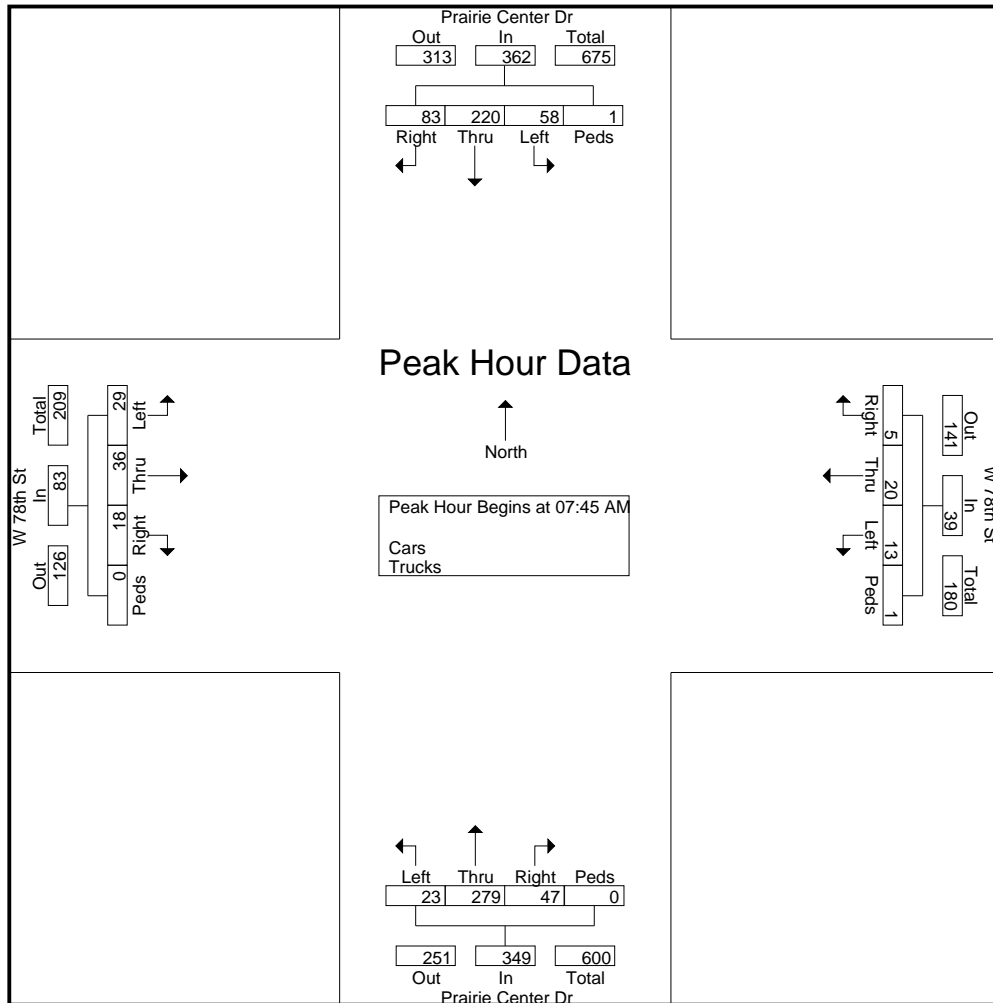

Alliant Engineering, Inc.

733 Marquette Ave #700, Minneapolis, MN 55402

Prairie Center Dr & W 78th St
 Ref Pt:
 data by: Alliant Inc
 TURN MOVEMENT COUNT

File Name : 17_EP_Prairie Center Dr at W 78th St
 Site Code :
 Start Date : 12/8/2020
 Page No : 4

| Start Time | Prairie Center Dr Southbound | | | | | W 78th St Westbound | | | | | Prairie Center Dr Northbound | | | | | W 78th St Eastbound | | | | | Int. Total |
|--|------------------------------|------|------|------|------------|---------------------|------|------|------|------------|------------------------------|------|------|------|------------|---------------------|------|------|------|------------|------------|
| | Right | Thru | Left | Peds | App. Total | Right | Thru | Left | Peds | App. Total | Right | Thru | Left | Peds | App. Total | Right | Thru | Left | Peds | App. Total | |
| Peak Hour Analysis From 10:00 AM to 01:45 PM - Peak 1 of 1 | | | | | | | | | | | | | | | | | | | | | |
| Peak Hour for Entire Intersection Begins at 12:00 PM | | | | | | | | | | | | | | | | | | | | | |
| 12:00 PM | 69 | 138 | 1 | 0 | 208 | 11 | 25 | 20 | 0 | 56 | 12 | 115 | 15 | 0 | 142 | 19 | 18 | 29 | 0 | 66 | 472 |
| 12:15 PM | 59 | 121 | 4 | 0 | 184 | 9 | 29 | 17 | 0 | 55 | 14 | 109 | 15 | 0 | 138 | 19 | 17 | 41 | 0 | 77 | 454 |
| 12:30 PM | 44 | 123 | 5 | 2 | 174 | 2 | 21 | 14 | 1 | 38 | 16 | 127 | 19 | 0 | 162 | 19 | 21 | 35 | 1 | 76 | 450 |
| 12:45 PM | 43 | 111 | 12 | 0 | 166 | 4 | 21 | 12 | 0 | 37 | 13 | 112 | 22 | 0 | 147 | 27 | 18 | 31 | 0 | 76 | 426 |
| Total Volume | 215 | 493 | 22 | 2 | 732 | 26 | 96 | 63 | 1 | 186 | 55 | 463 | 71 | 0 | 589 | 84 | 74 | 136 | 1 | 295 | 1802 |
| % App. Total | 29.4 | 67.3 | 3 | 0.3 | | 14 | 51.6 | 33.9 | 0.5 | | 9.3 | 78.6 | 12.1 | 0 | | 28.5 | 25.1 | 46.1 | 0.3 | | |
| PHF | .779 | .893 | .458 | .250 | .880 | .591 | .828 | .788 | .250 | .830 | .859 | .911 | .807 | .000 | .909 | .778 | .881 | .829 | .250 | .958 | .954 |

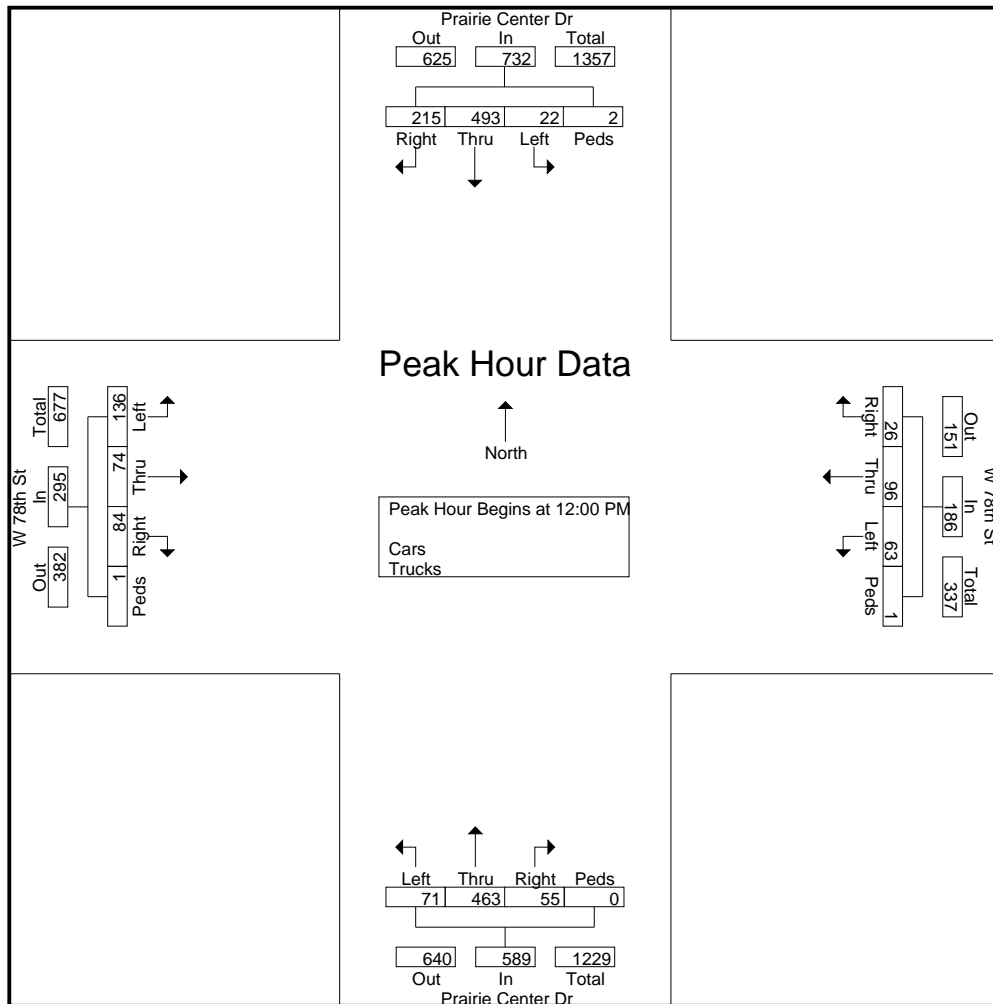

Alliant Engineering, Inc.

733 Marquette Ave #700, Minneapolis, MN 55402

Prairie Center Dr & W 78th St
 Ref Pt:
 data by: Alliant Inc
 TURN MOVEMENT COUNT

File Name : 17_EP_Prairie Center Dr at W 78th St
 Site Code :
 Start Date : 12/8/2020
 Page No : 5

| Start Time | Prairie Center Dr Southbound | | | | | W 78th St Westbound | | | | | Prairie Center Dr Northbound | | | | | W 78th St Eastbound | | | | | Int. Total |
|--|------------------------------|------|------|------|------------|---------------------|------|------|------|------------|------------------------------|------|------|------|------------|---------------------|------|------|------|------------|------------|
| | Right | Thru | Left | Peds | App. Total | Right | Thru | Left | Peds | App. Total | Right | Thru | Left | Peds | App. Total | Right | Thru | Left | Peds | App. Total | |
| Peak Hour Analysis From 02:00 PM to 05:45 PM - Peak 1 of 1 | | | | | | | | | | | | | | | | | | | | | |
| Peak Hour for Entire Intersection Begins at 04:30 PM | | | | | | | | | | | | | | | | | | | | | |
| 04:30 PM | 60 | 128 | 4 | 0 | 192 | 7 | 16 | 13 | 0 | 36 | 6 | 98 | 18 | 0 | 122 | 18 | 7 | 37 | 2 | 64 | 414 |
| 04:45 PM | 74 | 120 | 2 | 0 | 196 | 7 | 22 | 18 | 0 | 47 | 10 | 99 | 22 | 0 | 131 | 31 | 8 | 35 | 0 | 74 | 448 |
| 05:00 PM | 51 | 144 | 3 | 0 | 198 | 19 | 16 | 19 | 0 | 54 | 9 | 102 | 14 | 0 | 125 | 22 | 10 | 30 | 1 | 63 | 440 |
| 05:15 PM | 57 | 120 | 3 | 0 | 180 | 22 | 23 | 29 | 0 | 74 | 8 | 141 | 13 | 0 | 162 | 34 | 22 | 42 | 0 | 98 | 514 |
| Total Volume | 242 | 512 | 12 | 0 | 766 | 55 | 77 | 79 | 0 | 211 | 33 | 440 | 67 | 0 | 540 | 105 | 47 | 144 | 3 | 299 | 1816 |
| % App. Total | 31.6 | 66.8 | 1.6 | 0 | | 26.1 | 36.5 | 37.4 | 0 | | 6.1 | 81.5 | 12.4 | 0 | | 35.1 | 15.7 | 48.2 | 1 | | |
| PHF | .818 | .889 | .750 | .000 | .967 | .625 | .837 | .681 | .000 | .713 | .825 | .780 | .761 | .000 | .833 | .772 | .534 | .857 | .375 | .763 | .883 |

